

MicroGuard[®] 586

Rated Capacity Indicator/Limiter System

Industrial carrydeck cranes

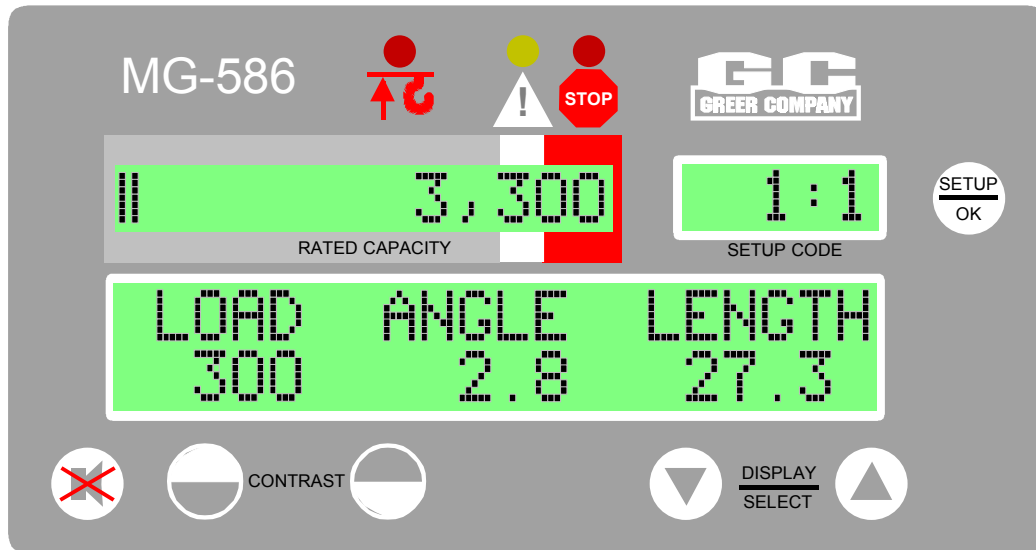

Operation

MicroGuard® 586
Rated Capacity Indicator/Limiter System
Operations Manual

Table of Contents

Overview	4
System Description	5-7
Operator's Display Console - Overview	8
Warning/Alarm Indications	8
Display Windows	8
Push Buttons	9
System Operation	10
System Self-Test	10
Adjusting Display Contrast	11
Configuration Selection	12-13
Stowed Jib Code	12
Parts-of-Line	13
Normal Operation	14
Approaching Overload	15
Maximum Capacity and Overload	16
Two-Block Warning	17
Alarm Override	18
Other Displayed Warnings	19
System Care	20-25
Routine Checks and Maintenance	20-25
Faults	26-27
System Fault Messages	26-27
Extension Reel Voltage Checks	28
Computer Internal Status Indicators	29
Power Indicator States and Actions	29
Communication Indicator	30

Overview

The MicroGuard® 586 Rated Capacity Indicator/Limiter System is an electronic system used in the operation of small cranes and boom trucks. The system is designed to provide the crane operator with information to aid in ensuring safe crane operation. The MicroGuard® 586 System is simple to operate. This manual describes the System and its operation.

PROVIDING THE CONTENTS AND INSTRUCTIONS CONTAINED WITHIN THIS MANUAL ARE CAREFULLY READ, UNDERSTOOD, AND FOLLOWED, THE OPERATOR WILL HAVE A CLEAR INDICATION OF RATED CAPACITY, APPROACH TO OVERLOAD, AND TWO-BLOCK CONDITIONS. HOWEVER, IMPROPER INSTALLATION OF THIS SYSTEM CAN RESULT IN SYSTEM MALFUNCTION.



The MicroGuard® 586 System is designed for use as an aid to crane operation. Do not use this system as a substitute for the experienced crane operator who has been trained in crane operation and related safety guidelines, or for crane capacity information and guidelines supplied by the crane manufacturer.

System Description

The MicroGuard[®] 586 Rated Capacity Indicator/Limiter System is a visual and audible alert system used in the operation of industrial cranes. The System, which includes a computer, an operator's display console, an extension reel, and various types of cables and sensors, is designed to measure and display load weight, calculate and display maximum capacity and percent rated capacity, display code configuration numbers, and warn of an approaching overload or two-block condition for each crane configuration.

Please refer to pages 6 and 7 of this manual. The **computer (L)** provides all of the functions necessary to read the System sensors, work out computations, and control the disconnect functions. In order to reliably calculate crane parameters, such as load and rated capacity, and interpret the crane capacity chart and code configuration numbers, information defining the physical characteristics of the crane has been loaded during factory setup.

Two **hydraulic pressure sensors**, housed in the computer, measure the pressure in both sides of the boom hoist cylinder. Other System sensors, mounted elsewhere on the crane, are connected to the computer via electrical cables.

The **extension reel (P)** measures the extended length of the telescoping sections of the boom and enables calculation of crane radius, load weight, and percent rated capacity. The **reel-off cable (M)** provides a path, from the boom head to the computer via the **extension reel computer cable (R)**. This path is used to signal a possible two-block condition. The **boom angle sensor (N)** measures the angle of the boom.

The **operator's display console (J)** translates data received from the computer and displays the actual load weight and percent of rated capacity in the **display console** windows. Visual and audible warnings and alarms activate when capacity limits are approached or exceeded, or when a two-block condition is encountered.

This manual describes the system components, the operation of the System, and includes maintenance recommendations.

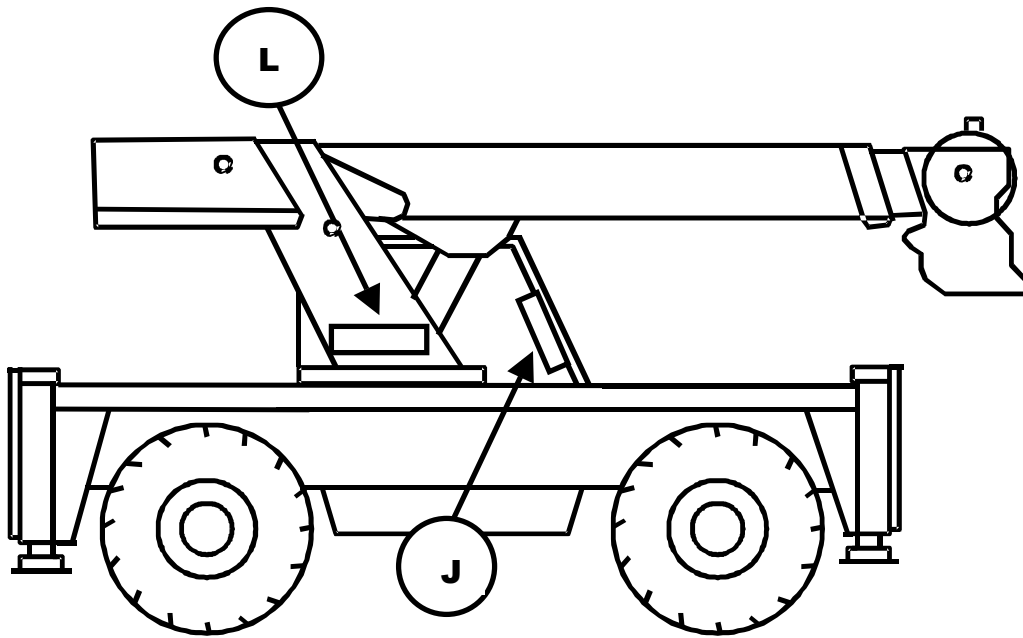

**The MicroGuard[®] 586
Rated Capacity Indicator/Limiter System
Industrial Machine**

- J** Operator's Display Console
- L** Computer with Hydraulic Pressure Sensors (inside)

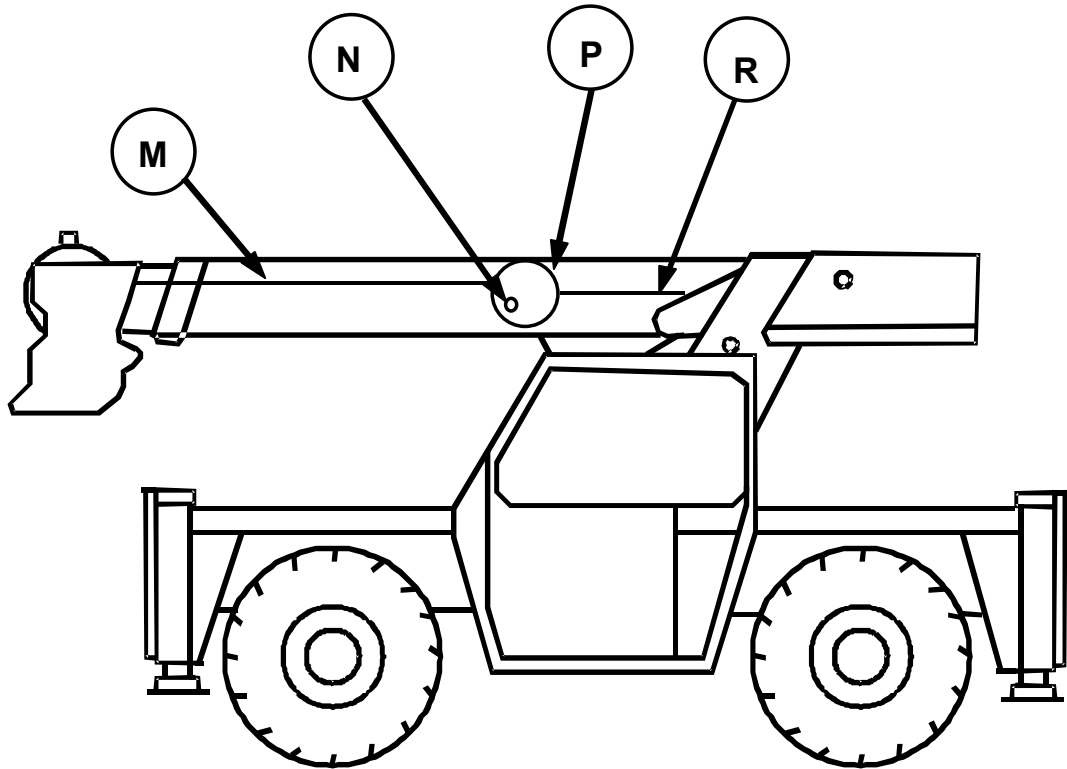

**The MicroGuard® 586
Rated Capacity Indicator/Limiter System
Industrial Machine**

M Off Cable to Boom Head

N Boom Angle Sensor (inside reel)

P Extension Reel

R Extension Reel Cable
to Computer

Operator's Display Console - Overview

Warning/Alarm Indications

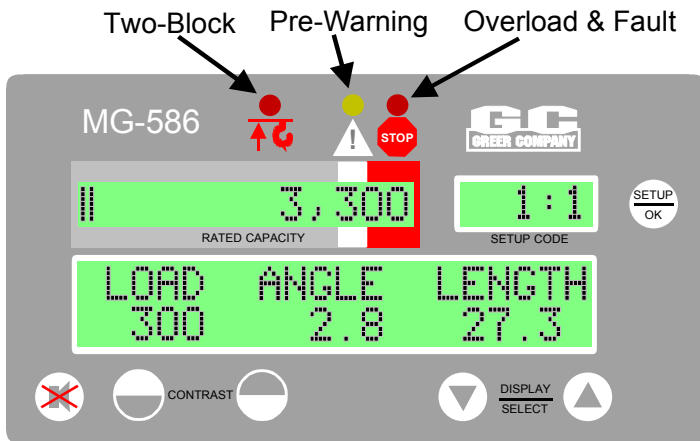

The red two-block indicator will light up when a two-block condition occurs.

The yellow pre-warning light will illuminate at a 90% approach to overload.

The red overload warning lamp will illuminate when the load reaches or exceeds 100% of the allowed capacity.

Display Windows

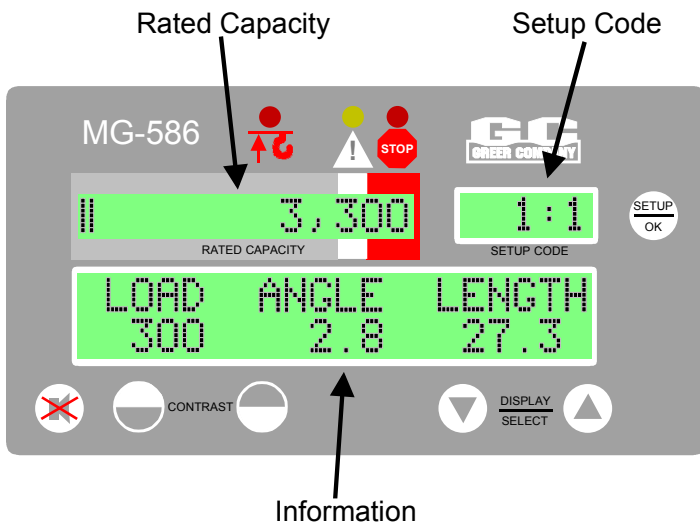

The current rated capacity for the crane in the given configuration will be displayed in this window along with the current percentage of rated capacity shown as a bar graph.

The system needs to be configured to match the current setup of the crane. The setup codes are shown in this window, along with the parts-of-line and the stowed jib option (if available).

The information window shows crane specific information regarding boom length, boom angle, and working radius, along with the load on hook. In addition, information regarding any warnings or alarms will be flashed in this display area.

Push Buttons

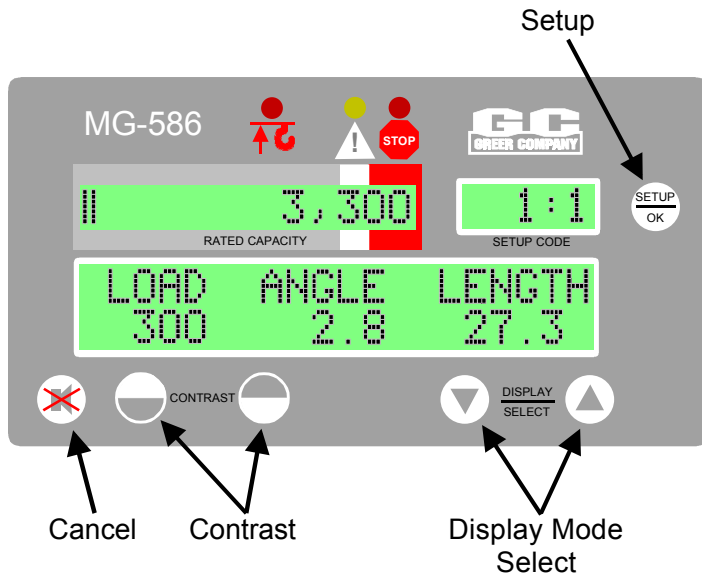

The **setup button** allows the operator to configure the system to match the actual setup of the crane.

Codes are present for:

- crane configuration.
- number of parts-of-line.

The **cancel key** is used to cancel the audible warning and to override the function kickout during alarm conditions.

The **contrast keys** are used to adjust the contrast of the display area.

The **display mode keys** are used to switch to different display formats showing various combinations of boom angle, boom length, and radius.

System Operation

System Self-Test

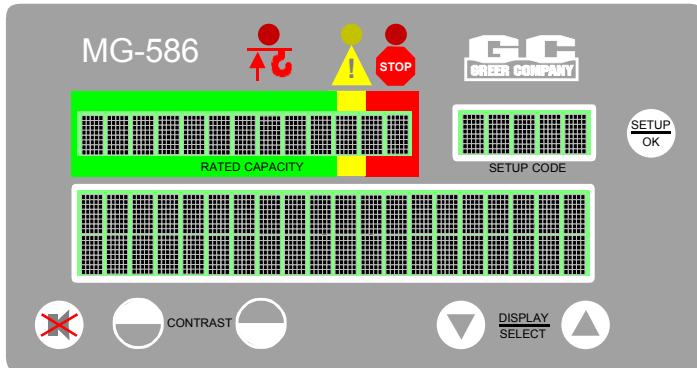

When the System is turned on, it briefly goes through a self-testing process.

The display should look like the illustration to the left.

All three alarm indicators will light up, all display windows will appear black, and the audible alarm will sound.

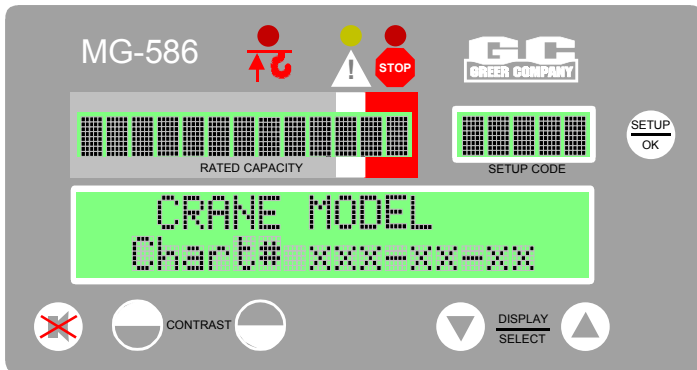

The information display will now show the crane model and capacity chart number for the System configured.

Setup Code

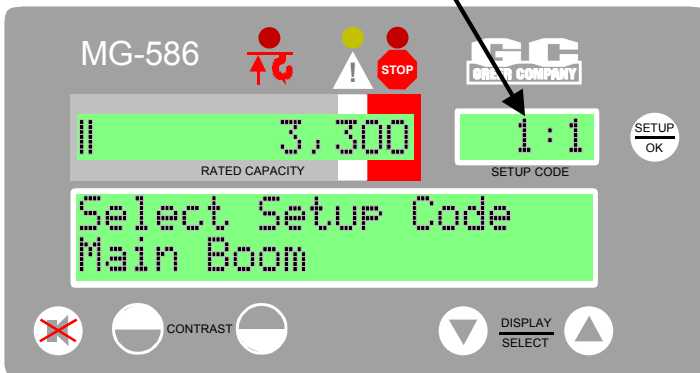

Following self-test, the System will go into the setup mode. The setup code window will display the same setup code used when the system was last powered off.

Check that the correct setup code is displayed before operating the crane.

See the Configuration Selection section for code setup instructions.

Adjusting Display Contrast

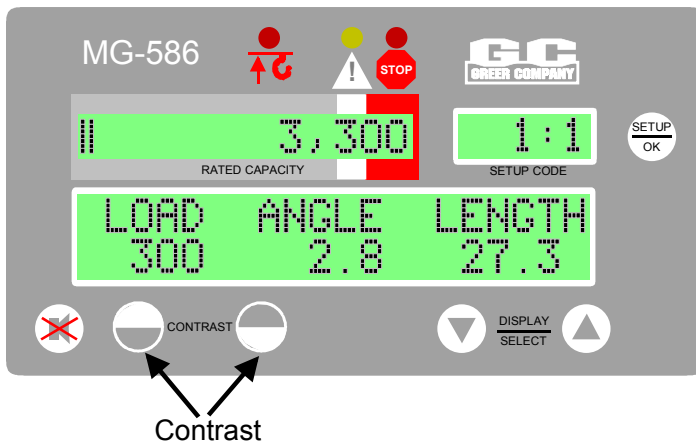

Changes in temperature and lighting conditions may require adjustment of the display contrast buttons.

Use the contrast adjustment keys to make the display area lighter or darker, as desired.

Configuration Selection

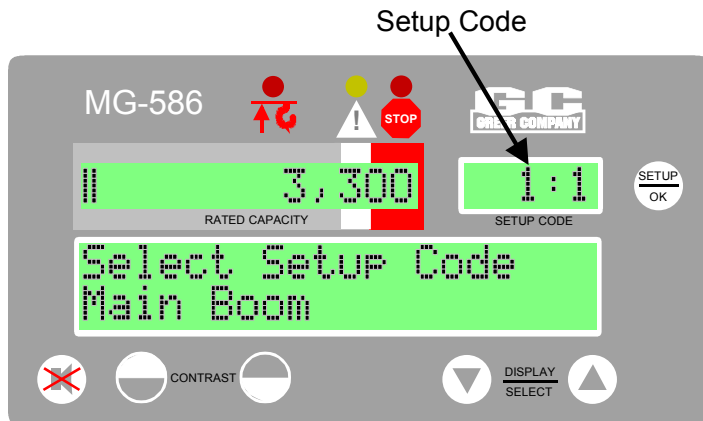

Configuration selection is required upon system power up; however, it can also be entered at any time by pressing the setup key.

The current configuration appears at the bottom of the display.

The configuration code will flash.

- To change the configuration code, use the display select arrows to show the desired option.
- Press the setup key to select and move on to the next stage.

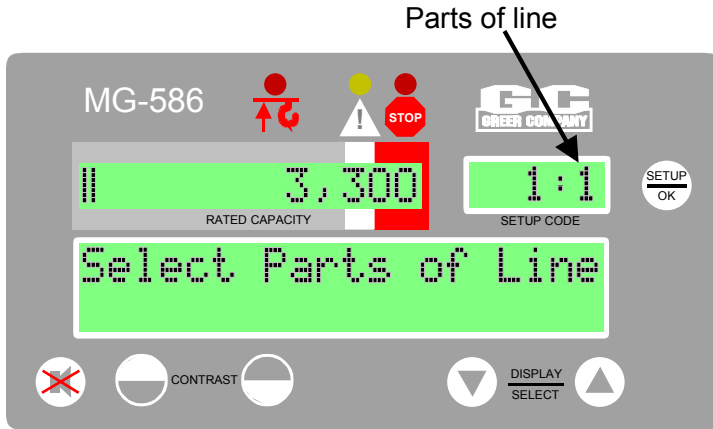

- The current number of parts-of-line is now flashing.
- To change the parts-of-line, use the display select arrow keys to display the desired number.
- To move to the next stage, press the setup key.

Note: Some configurations allow only single part-of-line operation.

In these cases, the whole parts-of-line selection phase will be skipped and the parts-of-line will be set to 1.

Once the correct parts-of-line are entered, the system will exit the configuration mode and return to the normal working screen.

Normal Operation

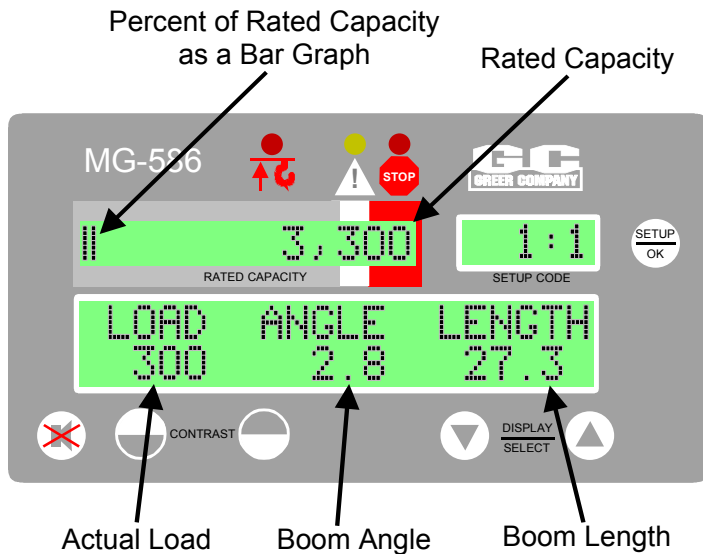

- **"Rated Capacity"** is the heaviest load that the crane can lift in the current crane position and configuration.
Note: This value may be limited by the number of parts-of-line selected.
- **"Percent of Rated Capacity"** indicates how near the operation is to full capacity and overload.
- The **Percent of Rated Capacity** is shown as a **bar graph**. This Bar Graph progresses to the right as the percentage increases.
- As long as the bar graph remains within the green-bordered normal zone, the Percent of Rated Capacity is within normal operating limits.

- The **weight** of the **"actual load"** appears in the display console window underneath the "LOAD" logo. The Actual Load includes the weight of the load plus the weight of everything hanging below the boom (hook block, etc.).
- Next to the "LOAD" logo is the "ANGLE" or "RADIUS" logo; this logo will switch **automatically** to match the current configuration (whether angle or radius related). The corresponding angle or radius value is displayed underneath on the bottom line.
- The final display logo will show "ANGLE", "RADIUS" or "LENGTH" by default. When operating, this display area will display "LENGTH". However, the display select arrow keys can be used to toggle this display area to show "ANGLE" (for a radius related configuration) or "RADIUS" (for an angle related configuration).
- If the system has any internal faults, it will display a fault message (see section on faults). These fault messages can be viewed by using the display select arrow keys to move to the fault message display.
Note: If there are no faults, no fault messages will appear.

Note: Both the bar graph and capacity share the same display window. The displayed capacity will move to the left of the bar graph when the bars value exceeds 60%.

Warning: The operator **must** select the correct crane configuration code number for each setup configuration change. Inaccurate or non-selection of the appropriate Code Number will result in incorrect calculations and readings of the **actual load** weight and **Percent of Rated Capacity**. Refer to Configuration Selection, page 12.

Approaching Overload

- The System monitors the weight of the load suspended below the boom head. The System compares this information with rated capacity data stored within the computer.
- When the rated capacity of the configuration reaches 90%, the **bar graph** in the window of the display console progresses from the normal (green-bordered) zone into the caution (yellow-bordered) zone.
- A **yellow light** above the caution zone of the bar graph lights up and an alarm beeps continuously.
- The message **“WARNING! – PRE-ALARM”** will flash in the information portion of the screen.

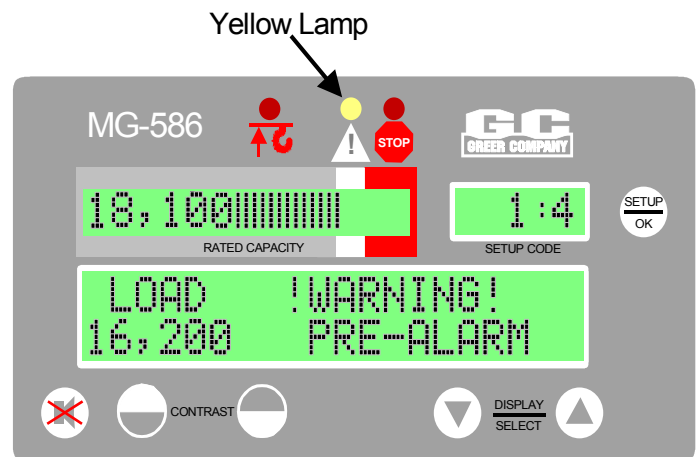

Maximum Capacity and Overload

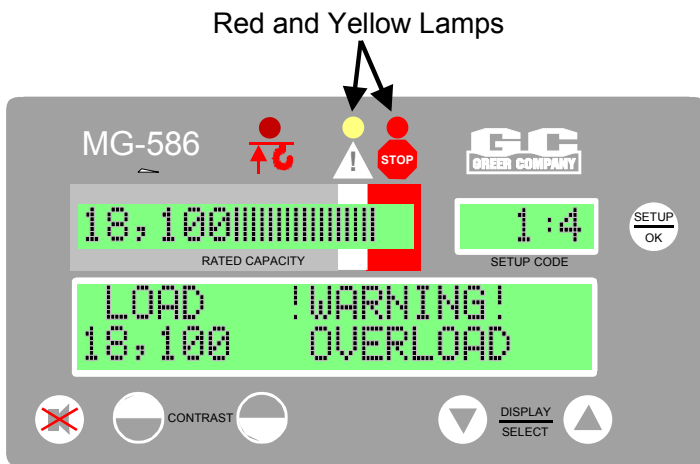

- When the rated capacity of the crane reaches 100%, the **bar graph** in the window of the display console moves from the caution (yellow-bordered) zone into the warning red zone.
- A **red light** above the alarm zone of the bar graph lights up and an alarm sounds continuously.
- **Crane motions** (boom extend, boom down, winch up, and swing left and right) are cut in order to prevent damage to the crane and the endangerment of persons near the lifting area.
- As the **bar graph** moves into the overload (red-bordered) zone, crane motions remain cut.

The message, “**WARNING! – OVERLOAD**” will flash in the information portion of the screen.

Two-Block Warning

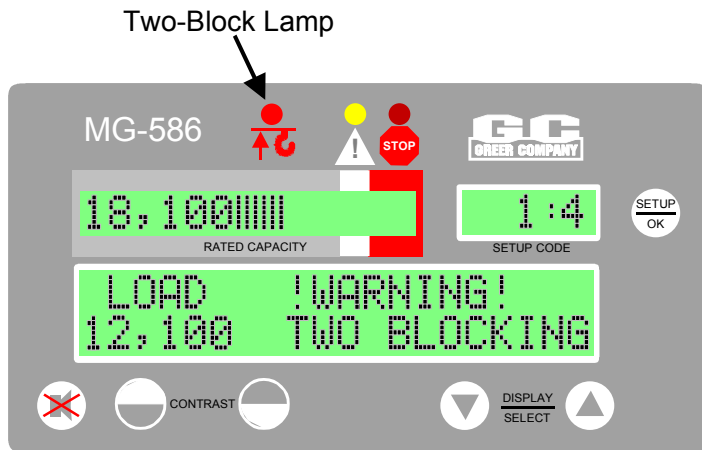

- A **red light** appears and an alarm sounds continuously when the hook block is on a collision course with the head machinery at the end of the boom.
- Crane motions (boom extend, boom down, and winch up) are cut in order to prevent damage to the crane and the endangerment of persons near the lifting area.

The message, **“WARNING! TWO BLOCKING”** will appear in the information area of the display.

Alarm Override

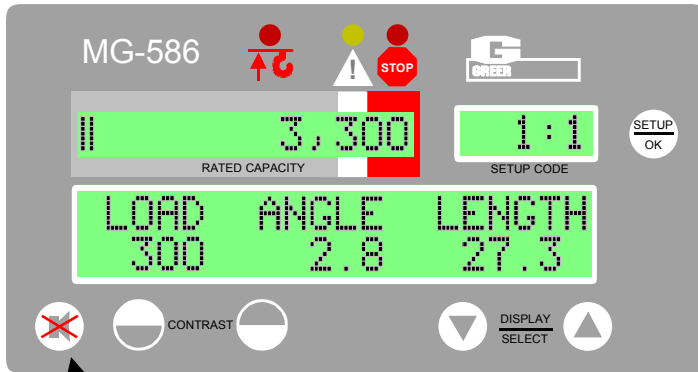

Cancel

The **alarm override button** is used to temporarily silence the **current** audible alarms and to disable the automatic motion cutout operation built into the System for protection.

The audible alarm will sound following any new occurrence of alarm. Overriding the audible alarm only cancels the audible warning for current alarms.

To deactivate the audible alarms, press the override button. Continue to hold the button down for 5 seconds to cancel any existing motion cuts. The override button must be held down to continue overriding the motion cut.



The alarm override button should be used with caution. Automatic audible alarms warning against overload, two-block dangers, and hazardous tipping conditions are temporarily silenced when this option is activated. Motion cutout may also be discontinued.

Other Displayed Warnings

Other warning messages that may flash on the display are shown below. If more than one warning is present at any one time, the system will display them in a strict rotation.

“MAX LOAD ROPE LIMITED”

This message can only accompany an overload or a pre-alarm warning. For example, such a message will be displayed if the maximum operational capacity of the crane is being limited by the number of parts-of-line.

“OPERATING OUTSIDE CHART!”

On certain capacity charts stored within the system, additional capacities may have been provided in order to allow crane movements in areas outside of the published capacity charts supplied with the crane. These capacities are determined by the manufacturer of the crane to be sufficient to allow movements during rigging, erection, and setup of the machine prior or subsequent to lifting operations. In such areas, the system displays a warning message, a yellow pre-warning light.

System Care

We recommend that the System checks (1 -9) be carried out when using the MicroGuard® 586 Rated Capacity Indicator/Limiter System.

1 Routine Checks and Maintenance

Items to Check before Each Shift or Crane Operation

- Crane configuration and System setup
- Extension reel – reel-off cable to boom tip – Extension reel cable to computer
- Hydraulic connections
- The anti-two-block weight
- The anti-two-block switch
- Checking the two-block warning signals and cutout of machine motions

MINIMUM MONTHLY CHECKS

- Load test

2 Routine Checks and Maintenance

Crane Configuration and System Setup

The **crane configuration** defines the physical setup of the crane. The **system setup** defines the load parameters for each configuration. The data for these calculations are loaded in the **capacity chart** and installed in the crane's computer prior to factory shipment.



ENSURE THAT THE **CONFIGURATION CODE NUMBER** IN THE DISPLAY CONSOLE WINDOW IDENTIFIES THE **CRANE'S CONFIGURATION** FOR THE CURRENT OPERATION. IF IN DOUBT, SELECT THE CODE NUMBER AGAIN FOLLOWING THE STEPS OUTLINED IN THE SECTION ON **CRANE OPTIONS AND SETUP CODES**.

CHECK THE ABOVE OPERATIONS BEFORE EACH SHIFT OR CRANE OPERATION

3 Routine Checks and Maintenance

Extension Reel

The extension reel houses the reel-off cable to the boom tip, a cable from the extension reel to the computer, and the boom angle sensor. The extension reel **provides the following signals** that are sent directly to the computer via the extension reel computer cable.

- **Boom Extension Signal** – generated within the extension reel, and controlled by the reel-off cable, as the boom is extended or retracted. The extension reel measures the boom extension and provides a signal, which enables the computer to calculate the operating radius of the crane, the weight of the actual load, and the percent of rated capacity.
- **Two-Block Signal** – transmitted from the boom head, through the reel-off cable, to the extension reel and the extension reel cable to the computer. This signal becomes active when the anti-two-block switch opens, indicating a two-block condition. When this signal reaches the computer, it causes an immediate display of a flashing light and an audible alarm on the operator's display console, and the motion cutouts are activated.
- **Boom Angle Signal** – is generated within the extension reel, and designed to measure the angle of the boom relative to the horizon.

CHECK THE ABOVE OPERATIONS BEFORE EACH SHIFT OR CRANE OPERATION

4 Routine Checks and Maintenance

Reel-Off Cable

The reel-off cable (extension cable) extends from the extension reel to the boom tip. The reel-off cable provides an electrical path for passage of the two-block warning signal from the boom tip to the computer cable in the extension reel.

Check Points:

- Carefully examine the reel-off cable for damage.
- Fully telescope the boom in and out. As you extend or retract the boom, ensure that the reel-off cable is smoothly fed on and off the extension reel without drooping along the boom or jumping, especially as the boom is telescoped in.

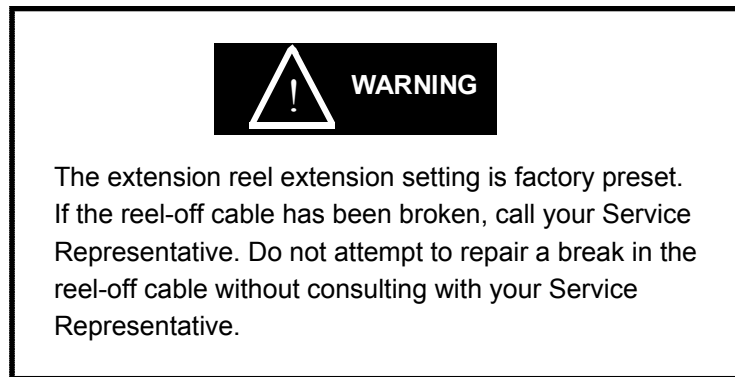

Computer Cable

The extension reel cable to the computer acts as a channel for passage of signals to the System computer.

Check Points:

- Ensure that the cable exiting from the extension reel and running down the boom and around its pivot to the computer is free from damage. If this cable has been **damaged in any way**, it should be carefully tested and may need to be replaced to ensure accurate transmission of signals.

CHECK THE ABOVE OPERATIONS BEFORE EACH SHIFT OR CRANE OPERATION

5 Routine Checks and Maintenance

Hydraulic Connections

The two hydraulic pressure sensors, mounted in the computer, measure the pressure within each side of the boom hoist cylinder. The pressure sensors are connected to the boom hoist cylinder valve block by two flexible hoses. Both hoses are subject to the full hydraulic pressure contained within the upper and lower sides of the boom hoist cylinder.

Check Point:

- Ensure that there are no hydraulic leaks at either connection end of both hoses. Check for signs of wear or damage along the length of each hose.

CHECK THE ABOVE OPERATIONS BEFORE EACH SHIFT OR CRANE OPERATION

6 Routine Checks and Maintenance

Checking the Two-Block Warning Signals and Cutout of Machine Motions

The following test activates the anti-two-block warning signals and the valve controlling cut out of crane motions to ensure proper operation. **No other pre-existing alarm conditions may be active when performing this test.**



1. Before performing this test, turn the crane power off and then on again to ensure that an existing two-block warning and/or motion cut has not been overridden.
2. During this test, **do not** use the cancel alarm button to clear audible warnings or motion cuts.
3. During this test, **operate the crane motions with extreme caution.**

TEST FOR OPERATION OF TWO-BLOCK WARNINGS AND CUTOUT OF CRANE MOTIONS

1. Slowly raise the hook block until it activates the anti-two-block switch at the boom head.
NOTE: This action should cut out the *winch up* motion as well as the *boom down*, *boom extend*, and *swing left and right* motions. Audible and visual alarms on the operator's display console should become active.
2. Lower the hook block by winching down.
NOTE: This action should disable the audible and visual alarms on the operator's display console and activate the boom motions.



CHECK THE ABOVE OPERATIONS BEFORE EACH SHIFT.

7 Routine Checks and Maintenance

Load Test

The best way to identify a possible problem in the System is to do a **load test**. The accuracy of the **load test** is dependent upon accurate operation of all of the sensors in the System and the correct **code number** setting for the configuration of the crane.

If no stowed deduct configuration is provided by the system, perform this test with stowed attachments removed.

It is recommended that a load test be performed monthly.



Ensure that the **configuration code number** in the display console window identifies the **crane configuration** for the current operation. If in doubt, select the Code Number again following the steps outlined in the **CRANE OPTIONS AND SETUP CODES**.

Load Test Steps

1. Select a known weight of at least 20% of maximum rated capacity.
2. Calculate the weight of the total load, including the slings and hook block.
3. Lift the weight, and record the load weight displayed on the MicroGuard® 586 operator's display console. The load weight on the console should be between 0 to 10% higher than the load that was lifted.

EXAMPLE:

When lifting 5000 lbs., the display console window should read between 5000 and 5500 lbs.



A load reading on the MicroGuard 586 Operator's Display Console that falls outside of a 10% range may indicate a sensor problem. Call your Service Representative.

MINIMUM SIX MONTHLY CHECK

Faults

System Fault Messages

When the MicroGuard® 586 System detects a fault, the red warning lamp will illuminate and the message, "WARNING: SYSTEM FAULT" will flash on the display. When a more serious fault is detected, the message, "WARNING: SYSTEM OUT OF SERVICE" may flash.

To determine the nature of the problem, press the UP or DOWN arrow key once or twice, which will change the display mode and exhibit the related fault message. This message will appear for up to 20 seconds before the display returns to the normal display mode. If the UP or DOWN arrow key is pressed before the 20 seconds have elapsed, the display will also automatically return to the normal display mode.

Fault messages that can appear on the display follow:

1. Reselect Crane Setup

This message indicates that there is an error in the CRANE SETUP selection, or there is an internal computer fault. Reselect the correct Crane Setup Code; the error should correct itself.

2. Check Extension

This message indicates a problem with the boom extension sensor.

- Inspect/check cabling and connections from computer to extension reel on the side of the boom.
- Inspect/check the extension reel-off cable for damage.

3. Check Angle

- This message indicates a problem with the boom angle sensor.
- Inspect/check cabling and connections from computer to extension reel on the side of the boom.

4. Check ATB Wiring

This message indicates an Anti Two-Block wiring problem usually due to an electrical short to the boom or a damaged cable.

- Inspect/check cabling and connections from computer to extension reel on the side of the boom.
- Inspect/check reel-off cable from extension reel to boom tip and Anti Two-Block switch connection.

5. Check FKO

This message indicates a Function Kick-Out wiring problem that is usually caused by a fuse or crane circuit breaker failure. Remove the computer unit lid and check the 10A fuse.

6. Replace System Chip

This message indicates a problem with the System chip fitted inside the computer.

Fault messages should be reported to the Service Representative along with any noticeable damage.

Extension Reel Voltage Checks

If problems occur with the Two-Block alarm operation, Angle, or Extension sensor, the following chart details voltage checks that may be made within the extension reel. Follow the action column before measuring voltages at the specified points in the voltmeter connection columns.

SIGNAL	BOOM POSITION / ACTION	VOLTAGE		VOLTMETER CONNECTION	
		MIN	MAX	RED (+)	BLACK (-)
SENSOR DRIVE	-	+4.7V	+5.3V	TB1/4 - RED	TB1/1 - BLUE
ANGLE SENSOR OUTPUT	0 Degrees	0.4V	0.6V	TB1/2 - GREEN	TB1/1 - BLUE
EXT'N SENSOR OUTPUT	0ft (0m) FULLY RETRACTED	0.15V	0.35V	TB1/3 - WHITE	TB1/1 - BLUE
TWO-BLOCK DRIVE	A2B WEIGHT DOWN	5.5V	7.5V	TB1/6 - BLACK	TB1/1 - BLUE
	A2B WEIGHT UP	9.5V	10.5V	TB1/6 - BLACK	TB1/1 - BLUE
TWO-BLOCK SIGNAL	A2B WEIGHT DOWN	5.5V	7.5V	TB1/5 - BROWN	TB1/1 - BLUE
	A2B WEIGHT UP	0V	2V	TB1/5 - BROWN	TB1/1 - BLUE

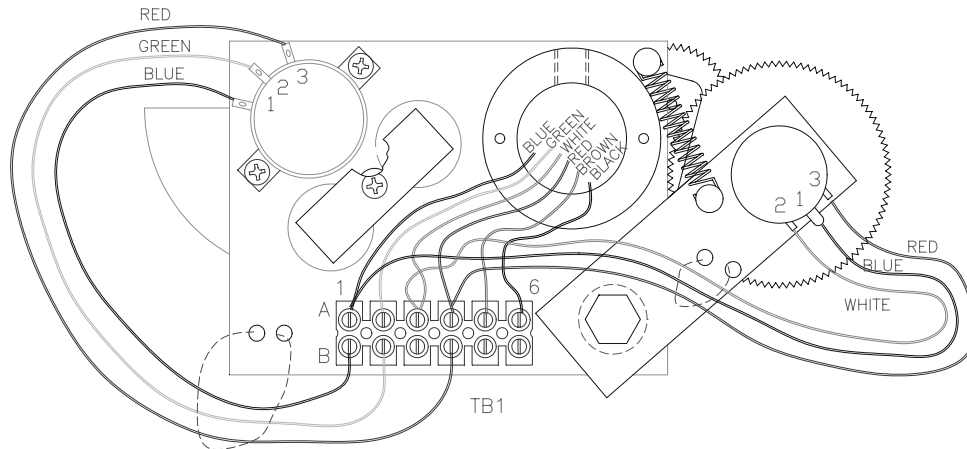

Notes:

- ANGLE SENSOR OUTPUT IS SET TO 10% (1/10th) OF SENSOR DRIVE VOLTAGE WITH BOOM AT ZERO DEGREES.
- EXTENSION SENSOR IS SET TO 5% (1/20th) OF SENSOR DRIVE VOLTAGE WITH BOOM FULLY RETRACTED.
- MEASURE ALL VOLTAGES WITH A DIGITAL VOLTMETER SET TO DC VOLTS RANGE.

Computer Internal Status Indicators

The computer unit contains six LED indicators that provide an aid to checking presence of power supply voltages and communications between the computer and display console.

All Indicators are bright green light emitting diodes. There are five power indicators (D2 through D6) and one communications indicator (D7).

With the exception of the communications indicator, all indicators should be illuminated at the same brightness level with the system power on.

A missing or dimly lit indicator indicates a power supply problem.

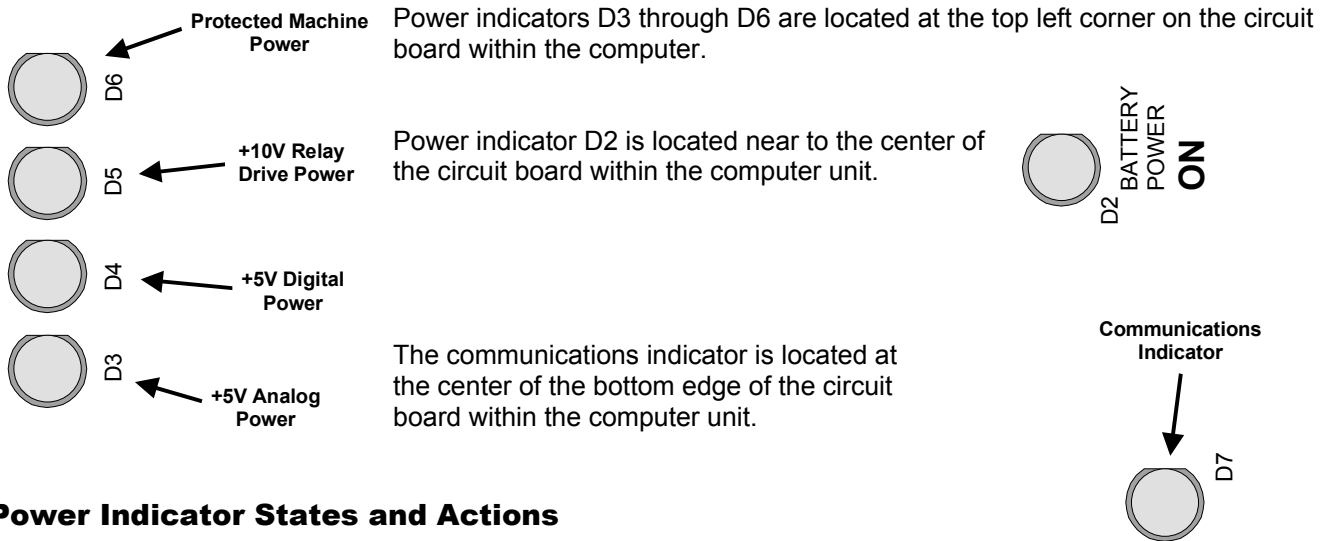

Power Indicator States and Actions

- **All indicators OFF**
Check power and ensure that PTO switch is properly engaged.
- **D2 ON but all other indicators OFF**
Check display console cable and connection.
- **D5 OFF but all other indicators ON**
Replace computer
- **D3, D4 and D7 OFF but all other indicators ON**
Replace computer
- **D3 OFF but all other indicators ON**
Check extension reel signal cable and internal voltages within extension reel.

Communication Indicator

The Communication Indicator provides an indication of the success or otherwise of communication with the display console, and of the running state of the computer program.

Carefully observe the Communication indicator and the display console at power on and through self-test, and then use the following chart to help decide the course of action.

COMMUNICATION INDICATOR indications at power ON	ACTION
<p>From the moment the system power is applied, the COMM indicator does not illuminate. During and after the self-test period of eight seconds, the COMM indicator remains off.</p>	<p>The computer is not running. Check status indicators (D2 through D6). Try to reset the system by powering off and on again. Listen to the computer for the relays to click. If they do not click, replace the System Chip - If not successful, replace the computer. If the relays do click, replace Communication chips IC1, 2.</p>
<p>From the moment the system power is applied, the COMM indicator does not illuminate. The display console, which never goes to normal, continually reads: "No Communication with MicroGuard."</p>	<p>Communication with the display has not been made. Is the display console connected? Check connector and cabling to the display console.</p>
<p>At the moment power is applied, the COMM indicator flashes briefly, then switches off. After a few seconds, the COMM indicator starts to flash at a fast rate and never stops.</p>	<p>This is the normal operation of the communication between the computer and display console.</p>

