

Greer Company

MicroGuard-500 Crane Data Sheet - Telescopic cranes

Information & outline of application requirements.

The completion of this application data sheet is required prior to the application of a MicroGuard-500 rated capacity indicator to any specific machine model. The information provided by this document is used to initialize the calibration of the rated capacity indicator in order to ensure minimum on-site calibration effort.

A full capacity chart with detailed notes and range diagrams is required in order to complete the system application.

Machine Outline

Crane Make & Model

Chart Numbers

Units of length
(Check appropriate box)

Feet

Meters

Units of force
(Check appropriate box)

Pounds*1000

Tons(US)

Tons(UK)

Tons(Metric)



PSR Professional Service & Repair Inc.

Professional Service & Repair Inc. is a full-service mobile crane repair, inspection, and certification company. At Professional Service & Repair we understand the critical aspect of your crane being operational to your project schedule and budget. We will deliver world class service to have your crane operational in the minimum amount of time.

PSR is the global provider for sales, repair and installation of Load Moment Indicating (LMI) systems, Anti-Two Block Systems (A2B), and Rated Capacity Indicating systems. Please contact us with your crane repair and certification needs today.

PSR is the name businesses trust for crane repair, inspection, and certification.

Main Line: 706-718-0856

Fax: 706-569-7004

E-Mail: jeff@psrinc.biz

**P.O. Box 6506
Columbus, GA
31917-6506**

Swing Data

The following dimensions are required when the rated capacity indicator is to be fitted with absolute measurement of swing angle with either a potentiometer or shaft encoder fitted within the center post or to the swing gear.

For machines fitted with swing switch area definition, indicate the appropriate arcs required by the chart.

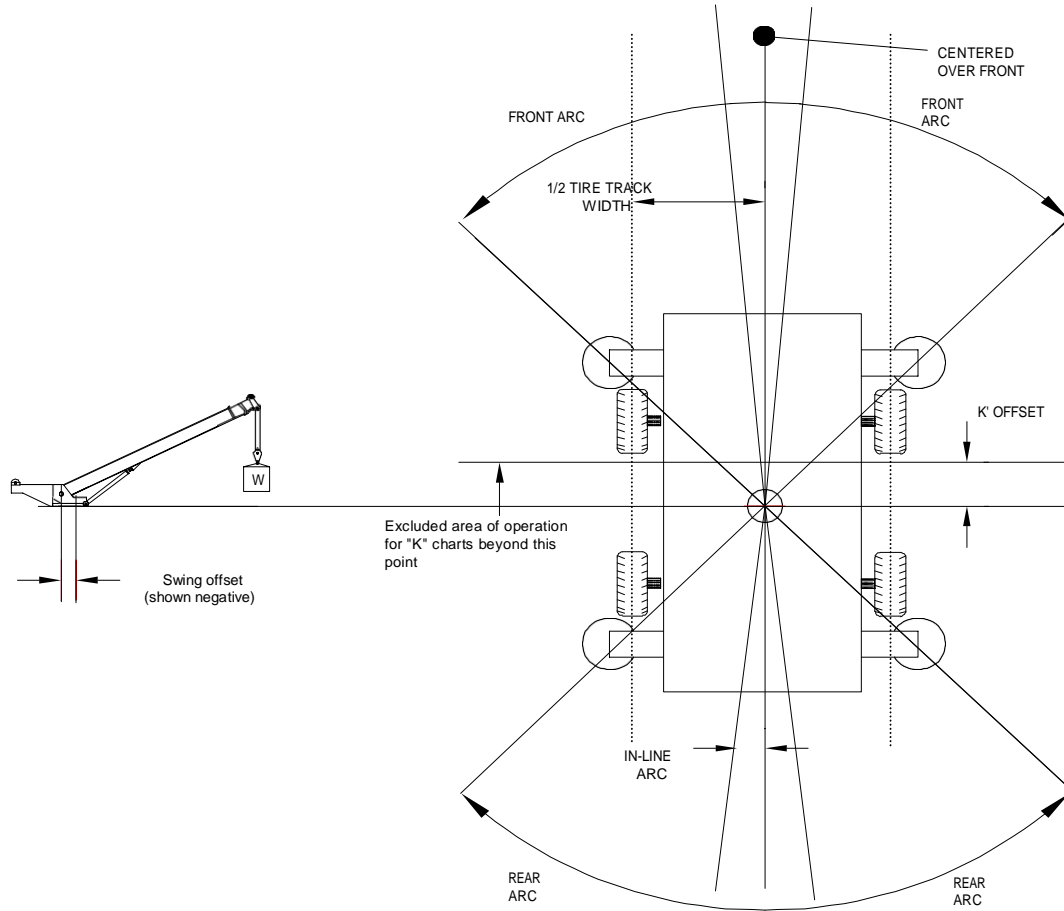

Lengths

Swing
Offset

1/2 Tire
Track
Width

"K" offset

Angles

FrontArc

RearArc

In-Line Arc

Boom Hoist Data

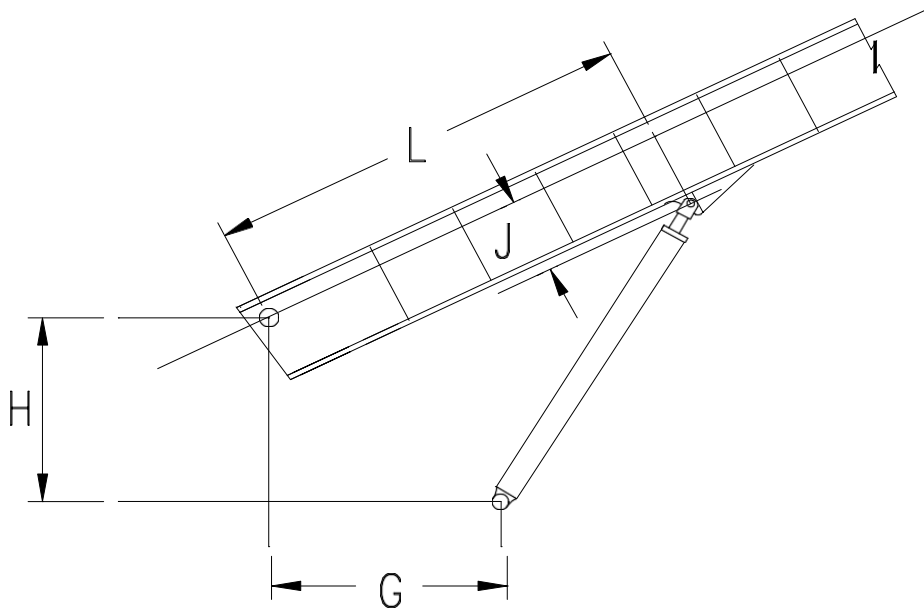

Lengths

L - horizontal along boom from boom pivot to upper cylinder pin

J - vertical across boom from boom pivot to upper cylinder pin

Note:
Dimension is negative when _____
boom pivot is above upper cylinder pin _____

G - horizontal between boom pivot and lower cylinder pin

H - vertical between boom pivot to lower cylinder pin

B - diameter of boom hoist cylinder bore

R - diameter of boom hoist cylinder rod

n – Number of Cylinders (1 or 2)

Winch Data

Winch dimensions are required to allow for compensation of moment arm created by the winch position. For winches mounted on the boom, dimensions are not required.

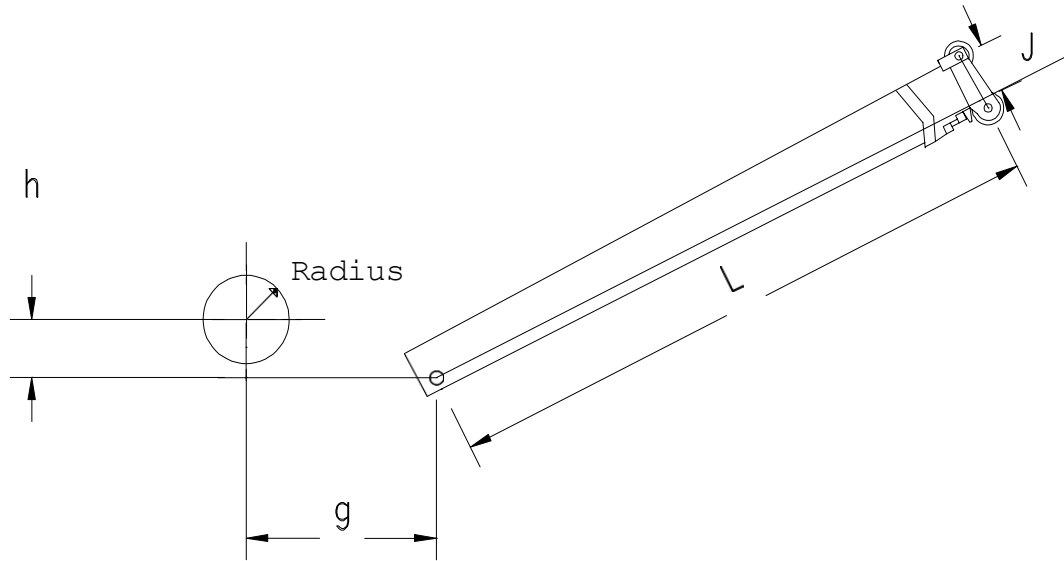

| | Main/Front winch | Aux/Rear winch |
|--|------------------|----------------|
| L - horiz'l along boom from boom pivot to top sheave center (boom retracted) | | |
| J - vertical across boom from boom pivot to top sheave center (boom retracted) | | |
| G - horizontal between boom pivot and winch center of rotation | | |
| H - vertical between boom pivot and winch center of rotation | | |
| R - winch radius (include 2 or 3 layers of rope) | | |
| F - maximum rated line pull standard rope | | |

Note: Dimension is negative when boom pivot is above winch center of rotation

Main Boom Data

Data for up to four main boom modes is allowed. Any configuration of the telescoping boom which is not detachable and will alter the operating length and/or moment will require a separate calibration. This will include: Booms with more than one telescoping sequence or boom + manual or powered telescoping tip extension.

Main boom head sheave radius

Maximum number of parts of line for main boom

Height of boom pivot above ground (on outriggers)

Main Booms cont'd

Describe each main boom configuration required.
Provide a sketch or separate drawing for each mode of operation in space provided.
Include telescoping sequences and manual/powered extensions.

Boom #1

Boom #2

Main Boom Data cont'd

Boom #3

Boom #4

Attachment Data

Attachments are extensions to the boom that are removable. Auxiliary heads should be included as an attachment.

The following attachment data should be specified as accurately as possible to avoid calibration errors.

Use data sheet on page 12 to indicate dimensions copy extra sheets as required.

Attachment length & head offset

Attachment length: distance along fly center line, between fly attachment lower mounting pin and attachment head sheave center.

Attachment head offset: Distance between attachment head sheave center and center line, perpendicular to center line.

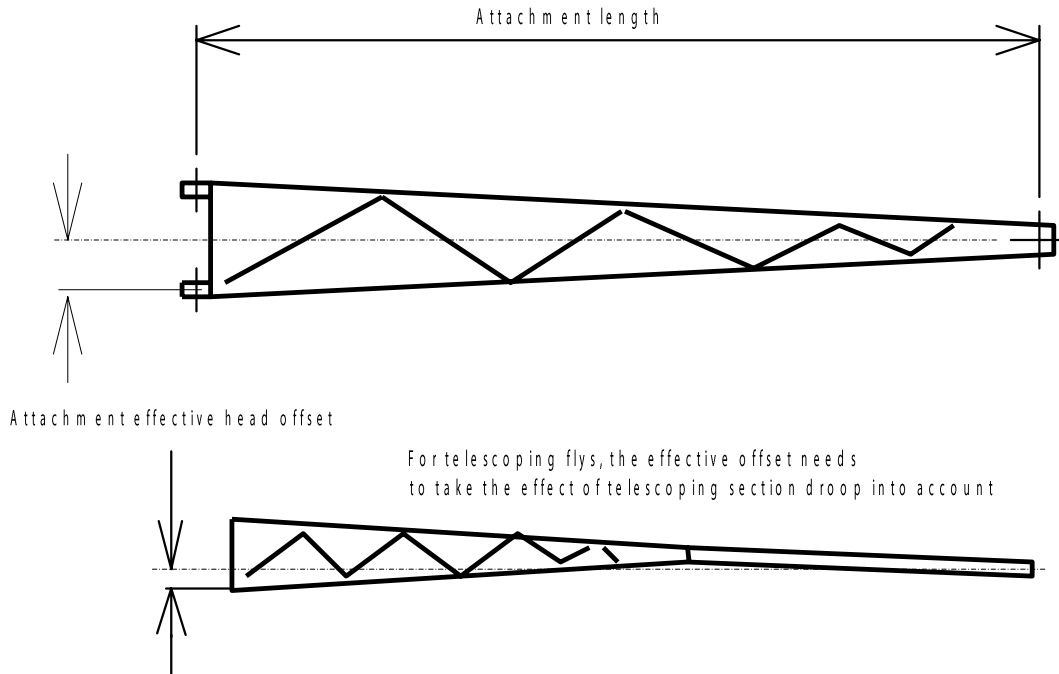

Attachment data cont'd

Attachment offset angle: Offset angle of attachment relative to main boom head (specify to nearest 0.1 degrees)

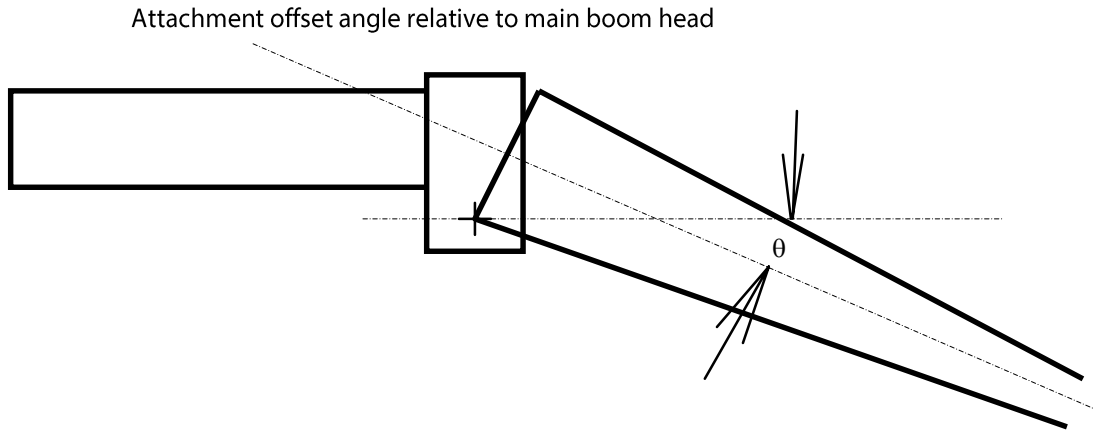

Attachment mounting offset

The following attachment mounting offset dimensions are usually not required, since most attachments are mounted to the main boom head sheave center.

Please indicate dimensions to nearest inch.

Attachment mounting offset (horiz): Distance between main boom head sheave center and center of attachment lower mounting point along boom center line.

Attachment mounting offset (vert): Distance between main boom head sheave center and center of attachment lower mounting point perpendicular to boom center line.

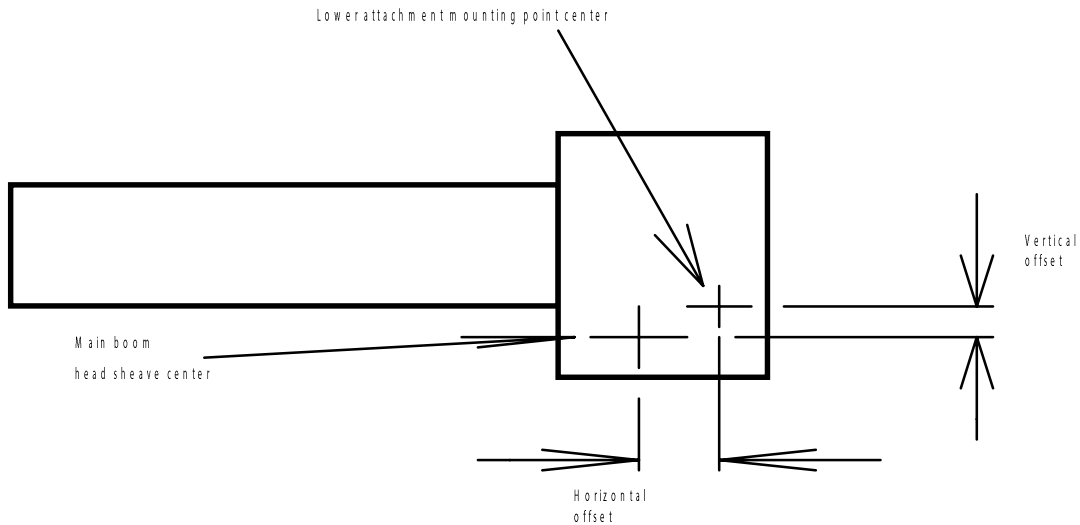

Attachment data cont'd

Attachment center of gravity (Erected)

Please indicate dimensions to nearest inch.

Attachment center of gravity (horiz): Distance between attachment lower mounting point and center of gravity along attachment center line.

Attachment center of gravity (vert): Distance between attachment lower mounting point and center of gravity perpendicular to attachment center line.

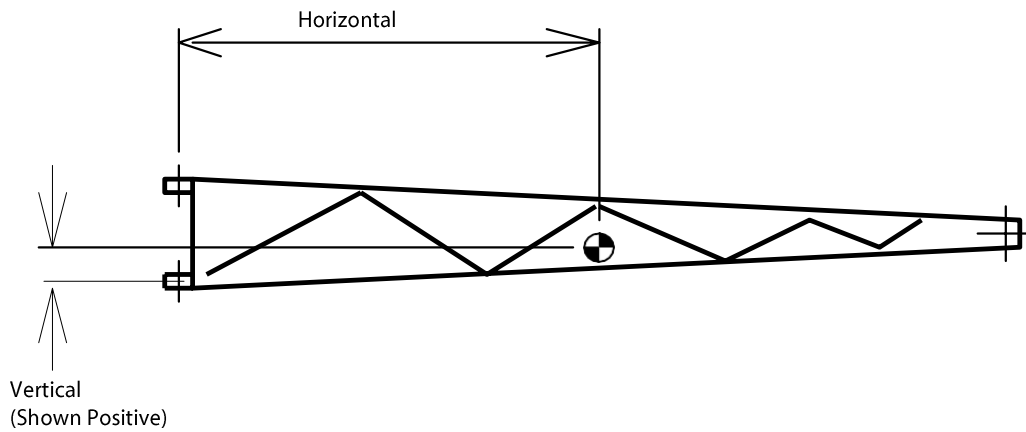

Attachment data cont'd

Attachment center of gravity (Stowed)

Please indicate dimensions to nearest inch.

Stowed attachment center of gravity (horiz): Distance between main boom pivot and center of gravity along main boom center line.

Stowed attachment center of gravity (vert): Distance between main boom pivot and center of gravity perpendicular to main boom center line.

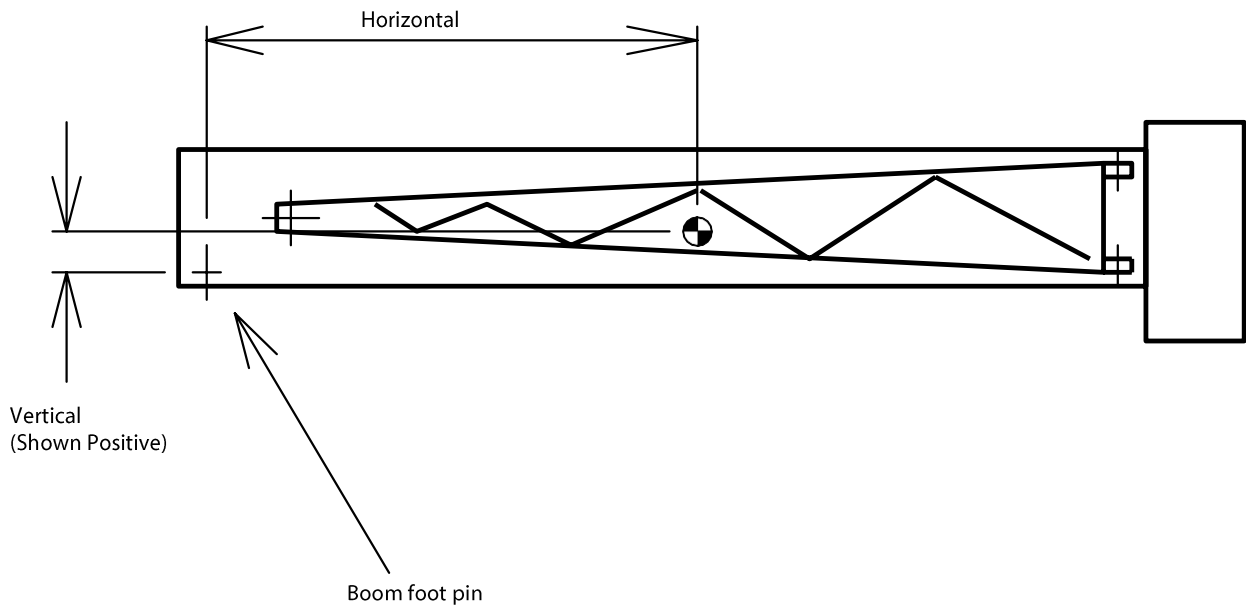

Attachment Data cont'd

| | Attachment #1 | Attachment #2 | Attachment #3 | Attachment #4 | Attachment #5 | Attachment #6 |
|---|---------------|---------------|---------------|---------------|---------------|---------------|
| Attachment name | | | | | | |
| l - Attachment length | | | | | | |
| s - Attachment head offset | | | | | | |
| h - Attachment mounting offset - horizontal | | | | | | |
| v - Attachment mounting offset - vertical | | | | | | |
| a - Attachment offset angles | | | | | | |
| g - Attachment center of gravity - horizontal | | | | | | |
| t - Attachment center of gravity - vertical | | | | | | |
| w - Attachment weight | | | | | | |
| r - Head sheave radius | | | | | | |

Stowed attachment

| | | | | | | |
|---|--|--|--|--|--|--|
| g - Attachment center of gravity - horizontal | | | | | | |
| t - Attachment center of gravity - vertical | | | | | | |
| Stowed deduct wt. | | | | | | |
| Erected deduct wt. | | | | | | |