



PSR Professional Service & Repair Inc.

Professional Service & Repair Inc. is a full-service mobile crane repair, inspection, and certification company. At Professional Service & Repair we understand the critical aspect of your crane being operational to your project schedule and budget. We will deliver world class service to have your crane operational in the minimum amount of time.

PSR is the global provider for sales, repair and installation of Load Moment Indicating (LMI) systems, Anti-Two Block Systems (A2B), and Rated Capacity Indicating systems. Please contact us with your crane repair and certification needs today.

PSR is the name businesses trust for crane repair, inspection, and certification.

Main Line: 706-718-0856

Fax: 706-569-7004

E-Mail: jeff@psrinc.biz

P.O. Box 6506

Columbus, GA

31917-6506

Table of Contents

Operation.....	3
SLI Assembly Groups.....	3
Cab components.....	4
Central Unit assembly groups	5
SLI Data Pick-ups.....	6
EKS83 Panel Face	9
Description of Operation – Electronic load moment limiting device EKS 83 (SLI).....	10
Selection of lifting capacity tables.....	10
Calculation of the radius.....	10
Calculation of the reference value	10
Calculation of the load.....	10
Warning and shutdown in case of overload.....	10
Data sensing.....	10
Data translation and transmission	10
Error Codes.....	11
Troubleshooting	12
IKS 83 Transducer Test Procedure	12
SLI shutdowns.....	13
Flowcharts.....	14
SLI Shutdown	14
No buzzer signal or displays	15
Information display shows letter a:	16
Information display shows letter c:	17

Information display shows letter d:.....	18
Information display shows letter e:.....	19
Information display shows letter f:.....	19
Information display shows letter L, M, or N:.....	20
Repairs.....	21
Checking the data transmitters.....	21
Fuses.....	22
Replacing the length measuring cable and setting the length measuring system.....	23
Replacing the length measuring cable.....	23
Checking and setting the length measuring system.....	25
Technical documents.....	26
Wiring Diagram.....	26
Pressure Transducers.....	28

Operation

SLI Assembly Groups

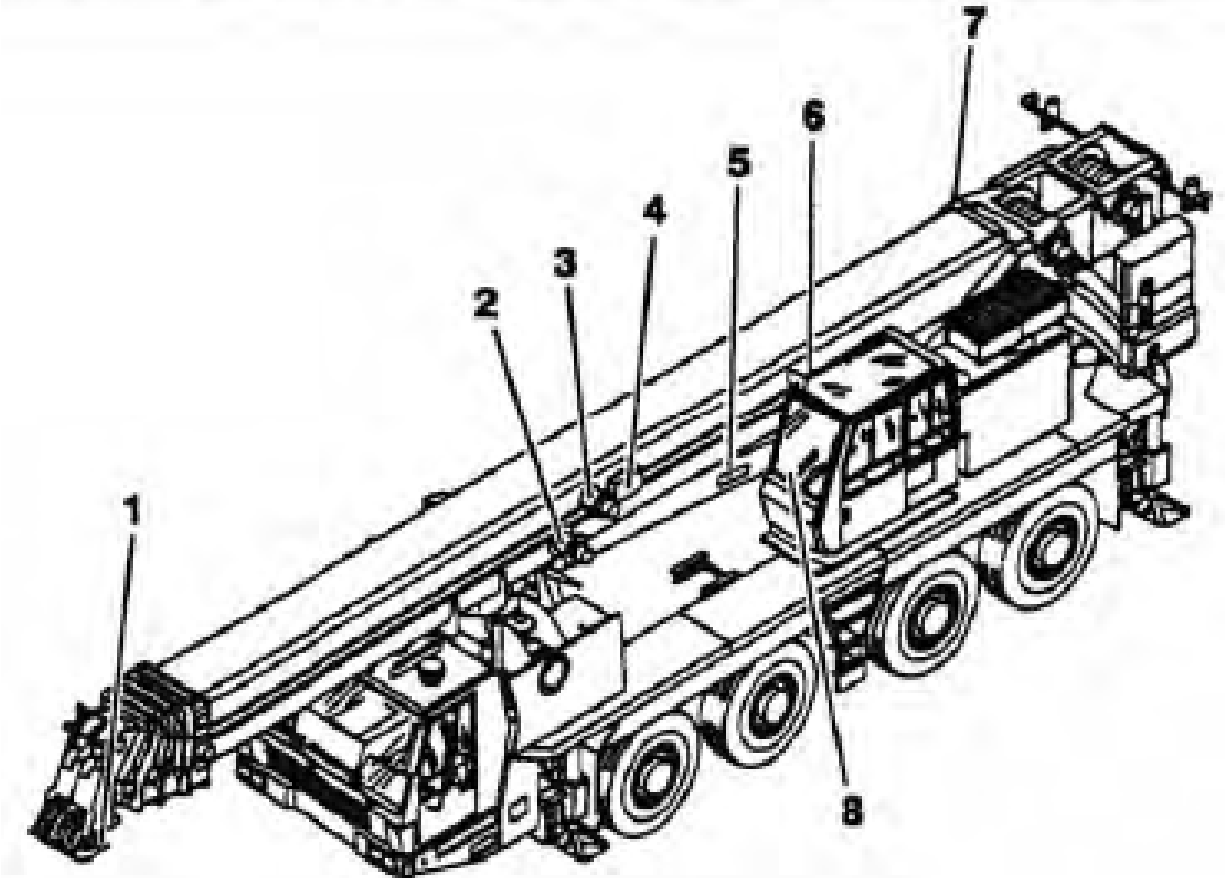

1. Lifting limit switch - main boom
2. Length measuring drum with potentiometer for telescope sections III/IV
3. Length measuring drum with potentiometer for telescope sections I/II
4. Boom unit with angle potentiometer and data transmitter for angle and length
5. Pressure sensor on derricking cylinder
6. Display unit on right-hand side of turntable
7. Data transmitter for pressure sensor on right-hand side of turntable
8. SLI central unit in the crane operator's cab

Cab components

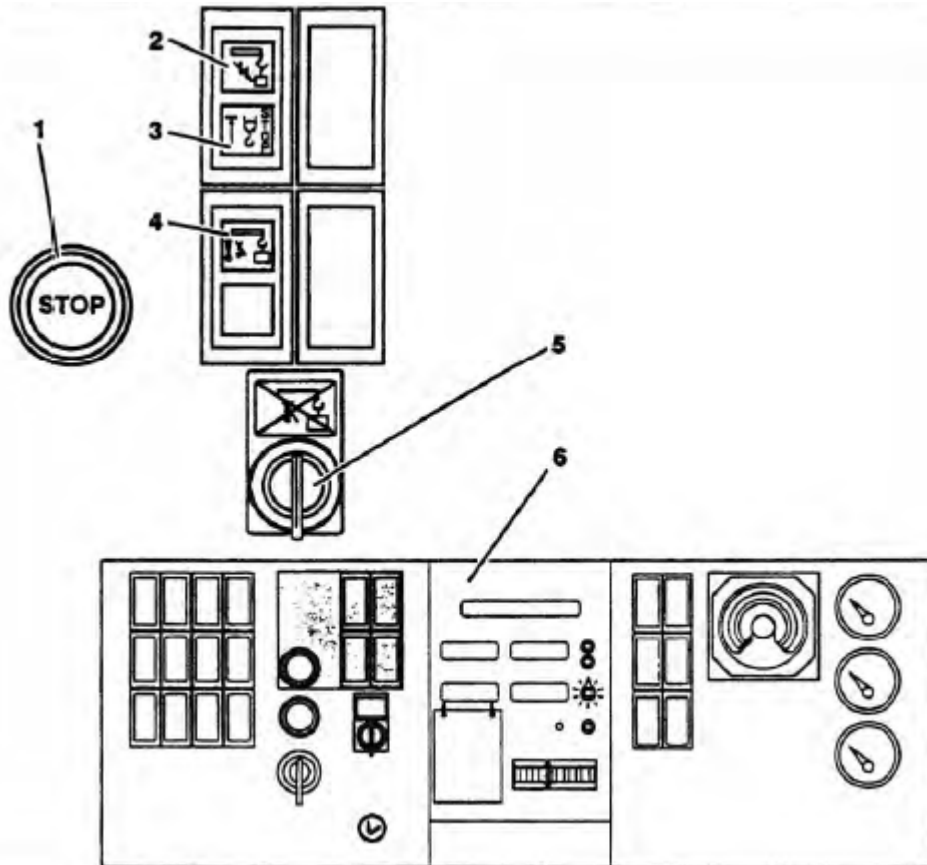

1. Push-button - crane engine cut-out ("stop engine")
2. Warning light - SU shutdown
3. Warning light - lifting limit switch
4. Warning light - SU warning
5. Key-operated switch - SU override
6. SU central unit EKS 83

Central Unit assembly groups

1. Mounting screws - Instrument panel
2. "ON" light
3. Supply voltage indicator light
4. Information switch "a" to "k"
 - a. Capacity utilization in %
 - b. Hook height in m
 - c. Main boom length in m
 - d. Main boom angle in degrees
 - e. No function
 - f. Piston surface pressure in derricking cylinder In bar
 - g. Piston ring surface pressure in derricking cylinder in bar
 - h. (h-k) No function
5. Warning light – shutdown
6. Release button
7. Switch for setting operating mode (SLI code)
8. Switch for setting reeving mode
9. 9 SLI brief information display
10. Display – information
11. Display – radius
12. Display - shutdown value
13. Display – load
14. Status display (operating modes, fault messages)
15. Fuse F2 (SU 2) for data bus (1.25 mA)
16. Plug X4 for 24 V power supply
17. Fuse F1 (SU 1) (3.15A)
18. Output X3 to crane electrics (shutdown signals)
19. Data bus connection supply XI for data transmitter
20. Additional outputs X5
21. Digital inputs X2

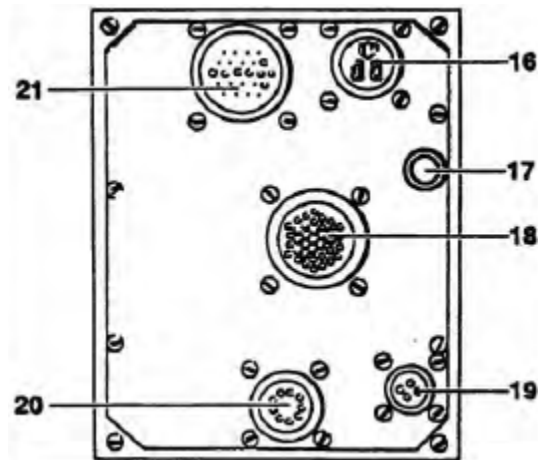
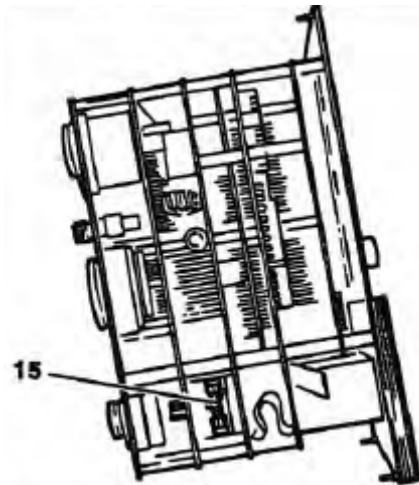
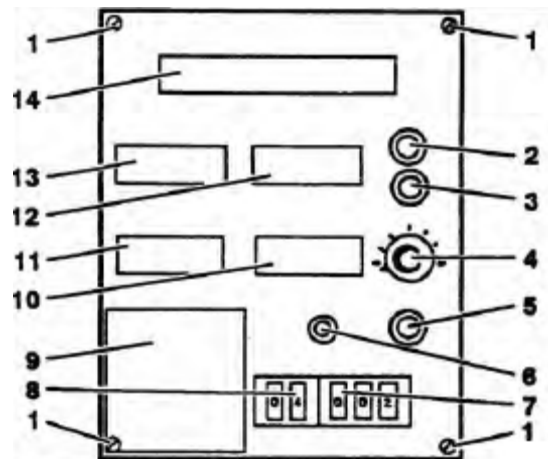

SLI Data Pick-ups

SLI data sensors and transmitters on boom

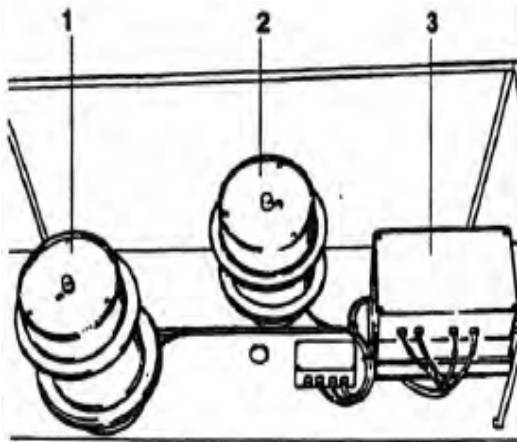

1. Cable drum with potentiometer for length - telescope sections III and IV
2. Cable drum with potentiometer for length - telescope sections I and II
3. Boom unit with angle measurement and data transmitter for angle and length

Boom unit with angle measurement

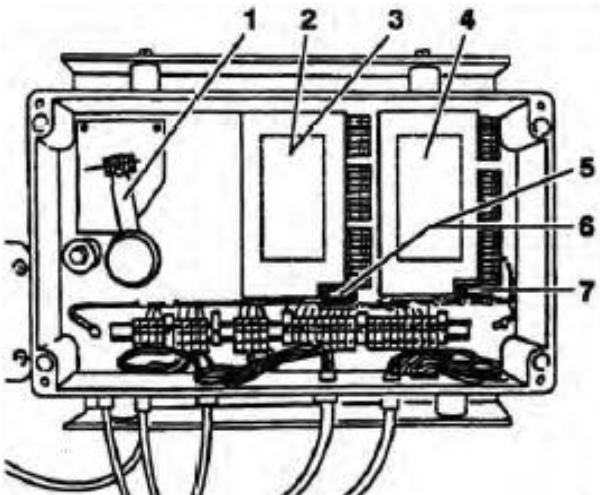

1. Angle potentiometer
2. Data transmitter (lower) - boom angle
3. Data transmitter (upper) - length

telescope sections 1/11

4. Data transmitter - length telescope sections III/IV
5. Fuse (lower) (SU 3) 0.16 A M (medium time-lag)
6. Fuse (upper) (SU 4) 0.16 A M (medium time-lag)
7. Fuse (SU 5) 0.16 A M (medium time-lag)

Cable drum with length measurement

1. Setting length potentiometer to left end position with telescope retracted

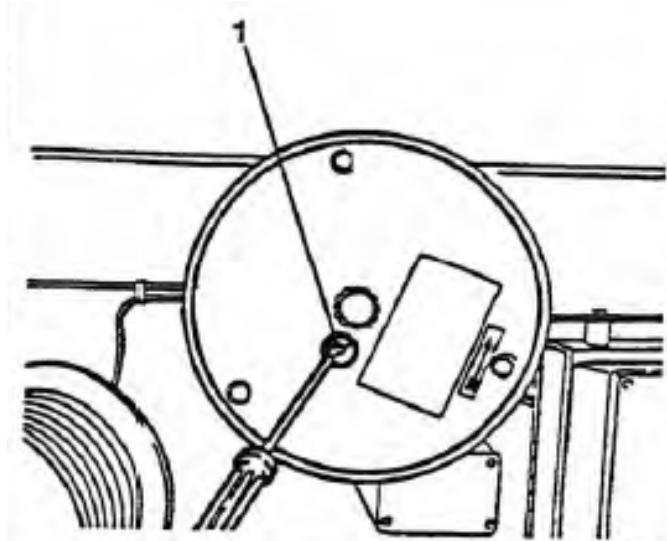

Data transmitter unit for upper chamber (piston ring surface) and lower chamber (piston surface)

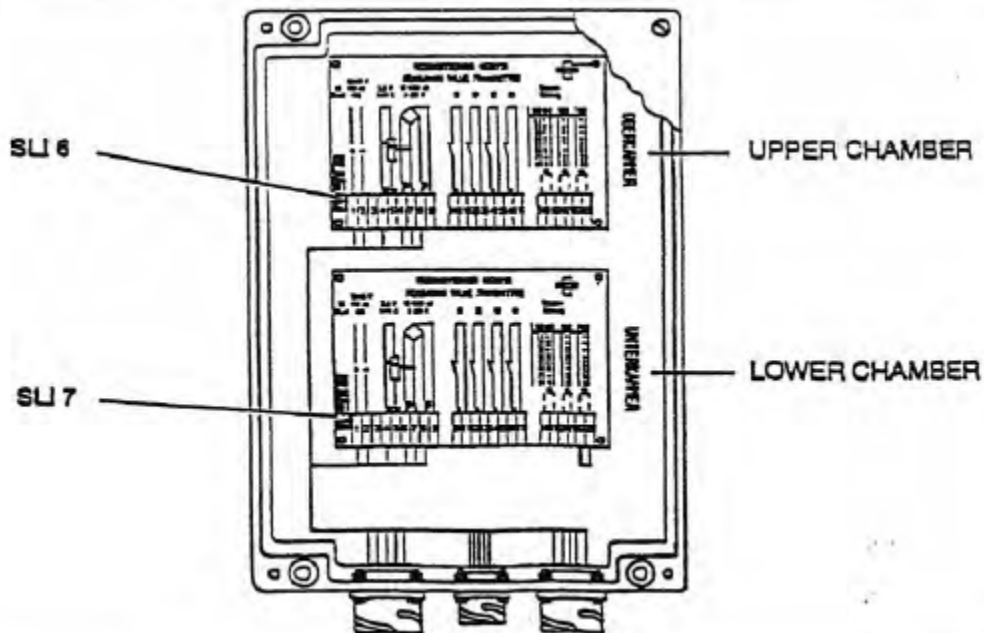

[Type text]

EKS83 Panel Face

Status Display

This includes outrigger configuration, counterweight swing limits and telescope sections percentage.

Actual Load

The current load within this load chart. Listed in lbs Extra rope, blocks, rigging considered load.

Load Radius Display

Radius is distance from center of rotation to center of free hanging load. Domestic cranes values shown in feet.

Calibration Port

Used by authorized GMK technician to enter new chart data. This port is normally covered and behind flip chart.

Ready Indicator

EKS has completed its diagnostic checks and is ready for lifting operations.

Lockout Threshold (lbs.)

This value is the rated capacity for this chart configuration. Changes with change of configuration.

Lockout Indicator

Load has exceeded lockout threshold. Requires crane be brought back into chart. Release button is then required continue lifting operations.



Description of Operation – Electronic load moment limiting device EKS 83 (SLI)

Selection of lifting capacity tables

The system selects the correct lifting capacity according to the operating mode set on the central unit and current boom configuration (length, telescope status, boom length).

Calculation of the radius

The radius is calculated from the boom length and angle as well as from the boom load derived from the hydraulic pressure measured in the derricking cylinder, taking the deflection of the boom into consideration. When the operating mode has been set the length of the boom and fixed angle position of the boom extension are included in the calculation.

Calculation of the reference value

Using the radius and boom length as a reference, the corresponding reference value (= maximum load with selected crane configuration) is selected from the lifting capacity table. The reference value is reduced, depending on the reeving mode set on the central unit.

Calculation of the load

The pressure measurement in the derricking cylinder produces a signal which is proportional to the measured load moment. After subtraction of the inherent moment of the boom, the actual load is calculated, taking into account the reeving configuration set on the central unit.

Warning and shutdown in case of overload

Reference value and calculated load are continually monitored and compared. If the load reaches the warning threshold (90% of the reference value), a warning is activated (intermittent buzzer, "Warning" relay, status indicator). If the load reaches the shutdown threshold (100% of the reference value), shutdown is activated. A continuous buzzer sounds and the red LED warning light "Shutdown" comes on. The "Shutdown" relay interrupts the power supply to the SU valve. The valve switches over and blocks the control pressure for the crane functions. The shutdown is displayed on the status display.

Measurement of variables

Data sensing

- Boom angle to the horizontal with pendulum-driven potentiometer.
- Boom length with potentiometer, driven by length measuring rope or wire and gear unit
- Derricking cylinder pressure with two pressure sensors in the lower chamber (piston surface chamber) and the upper chamber (piston ring surface chamber) of the derricking cylinder.

Data translation and transmission

The measured values are digitized in the data transmitter, converted into telegrams and transmitted time-delayed as impressed current to the central unit through the common dual-line data bus.

Error Codes

Collective Error	Individual Fault	Fault (Countermeasures)
a	1	Incorrect operating mode (check set operating mode and actual operating mode)
	2	Operating mode selector switch faulty (must be repaired)
	6	Telescope locking system (check telescope locking)
	7	Reeving mode (enter reeving condition)
	8	Operating mode not set on SU (cr. fault a1)
b	2	Additional switch for setting the operating mode is not set correctly
	3	(check position of additional operating mode switch)
c	1	Telescope section I not locked (lock telescope section I)
	2	Telescope section II not locked (lock telescope section II)
	3	Telescope section III not locked (lock telescope section III)
	4	Telescope section IV not locked (lock telescope section IV)
	7	Slewing angle restriction (return to restricted slewing range)
	8	Turntable locking system (pin not inserted)
d	1	Data transmitter "hydr. pressure ring area in derricking cylinder" (must be repaired)
	2	Data transmitter "angle of main boom" (must be repaired)
	3	Data transmitter "length of telescope sec. III" (must be repaired)
	4	Data transmitter "length of telescope sec. II" (must be repaired)
	5	Data transmitter "hydr. pressure piston area in derricking cylinder" (must be repaired)
	6	Data transmitter "length of telescope sec. I" (must be repaired)
	7	Data transmitter "angle - boom extension luffing fly jib angle" (must be repaired)
	8	Data transmitter "load - boom extension/load -luffing jib" (must be repaired)
e	1	Incorrect telescope section lengths (check set operating mode and actual operating mode)
	2	Radius (raise boom)
f	1	Boom angle (raise boom)
	2	Incorrect luffing fly jib angle (raise/lower boom or luffing fly jib)
	3	Slewing angle (return to restricted slewing range)
g	6	Data transmitter "length of telescope section IV-
t	4	Below minimum radius (lower boom)

Message	Cause
L	Overload (leave shutdown range)

M	Shutdown (leave shutdown range, and reset/repair SU)
---	--

N	Warning (shutdown level reached)
---	----------------------------------

Troubleshooting

IKS 83 Transducer Test Procedure

PURPOSE: TO VERIFY PROPER OPERATION OF THE BOOM CYLINDER PRESSURE TRANSDUCERS USING THE SLI INFORMATION DISPLAY CAPABILITY.

SET-UP: MACHINE MUST BE SET UP IN A NORMAL OPERATING CONFIGURATION, I. E. ON OUTRIGGERS.

PROCEDURE:

1. PLACE BOOM INTO BOOM REST.
2. CRACK TOP & BOTTOM BOOM CYLINDER BLEED SCREWS TO RELIEVE ANY RESIDUAL PRESSURE.
3. TURN INFORMATION KNOB TO POSITION "F" (PISTON SIDE PRESSURE), AND READ PRESSURE READING AT THE INFORMATION DISPLAY WINDOW. DISPLAY SHOULD INDICATE 0.0 + OR - 3.0. NOTE: PRESSURE READINGS ARE MEASURED IN BAR.
4. TURN INFORMATION KNOB TO POSITION "G" (RING SIDE PRESSURE), AND READ PRESSURE AT INFORMATION DISPLAY WINDOW. DISPLAY SHOULD INDICATE 0.0 + OR - 3.0.
5. TURN INFORMATION KNOB TO "F" AND RAISE THE BOOM TO THE MECHANICAL LIMITS OF THE BOOM CYLINDER. CONTINUE HOLDING BOOM RAISE CONTROL LEVER UNTIL SYSTEM RELIEF PRESSURE HAS STABILIZED. SEE THE UPPER HYDRAULIC SCHEMATIC FOR THE MACHINE BEING TESTED TO DETERMINE THE VALUE OF SYSTEM RELIEF PRESSURE. NOTE: IF HOOK AND/OR BALL ARE REEVED, EXERCISE CAUTION TO PREVENT THEM FROM SWINGING FORCEFULLY INTO THE BOOM AT THIS STEEP ANGLE!!

READ PRESSURE AT THE INFORMATION DISPLAY WINDOW. DISPLAY SHOULD INDICATE THE VALUE OF SYSTEM RELIEF PRESSURE + OR - 10 BAR. WHILE HOLDING BOOM RAISE CONTROL IN THE RAISE POSITION.

6. TO FULLY TEST RING SIDE TRANSDUCER, EXCHANGE WITH PISTON SIDE TRANSDUCER AND REPEAT TEST.

SLI shutdowns

The SU triggers. shutdown, an acoustic signal sounds, the letter E flashes on the left-hand side of the status display (1) and indicator lamp (3) “shutdown” lights up If:

- the shutdown value is exceeded
- if any of the faults listed in the table *·Status messages·* occur.

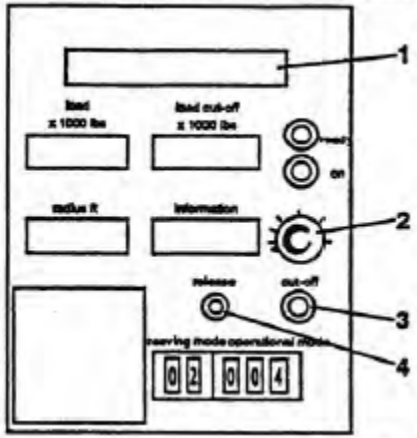

- The alarm can be switched off by pressing the release button (2).
- If you know why the shutdown has occurred, e.g. the shutdown value has been exceeded by lowering the boom; you can stop the shutdown by leaving the shutdown range.
- This is done by putting down the load, raising the boom or retracting the telescope sections of the main boom.

Retracting the telescope sections should be avoided if possible, however, as - depending on the position of the telescope sections- the SLI will switch over to a different lifting capacity range (e.g. from fixed length to Intermediate length), please see Section 4.6.15 "Telescoping the boom".

If you have not already switched off the alarm, the “release” button must then be pressed after you have left the shutdown range to stop the shutdown.

If you do not know why the shutdown has occurred, hold the release button down.

After approximately 1 second, the status display will change:

..... f M b =

..... f M f = 1

- If, for example, the Information switch is In position b:
- Continue to hold down the release button and turn the Information switch to position f.
- In the table *“status messages”* you will find under f=1 that the angle of the boom is

below the minimum value.

Flowcharts

SLI Shutdown

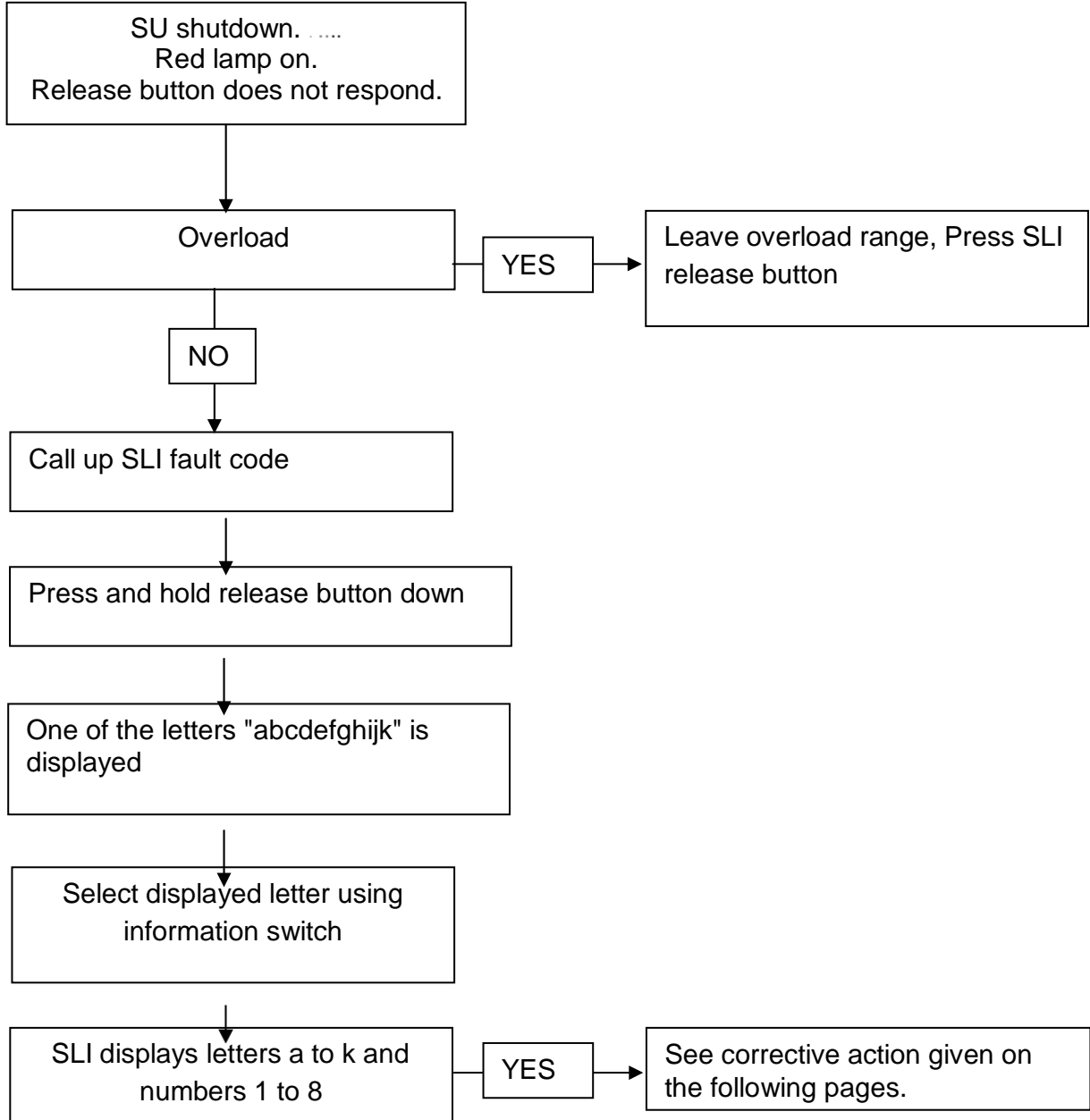

No buzzer signal or displays

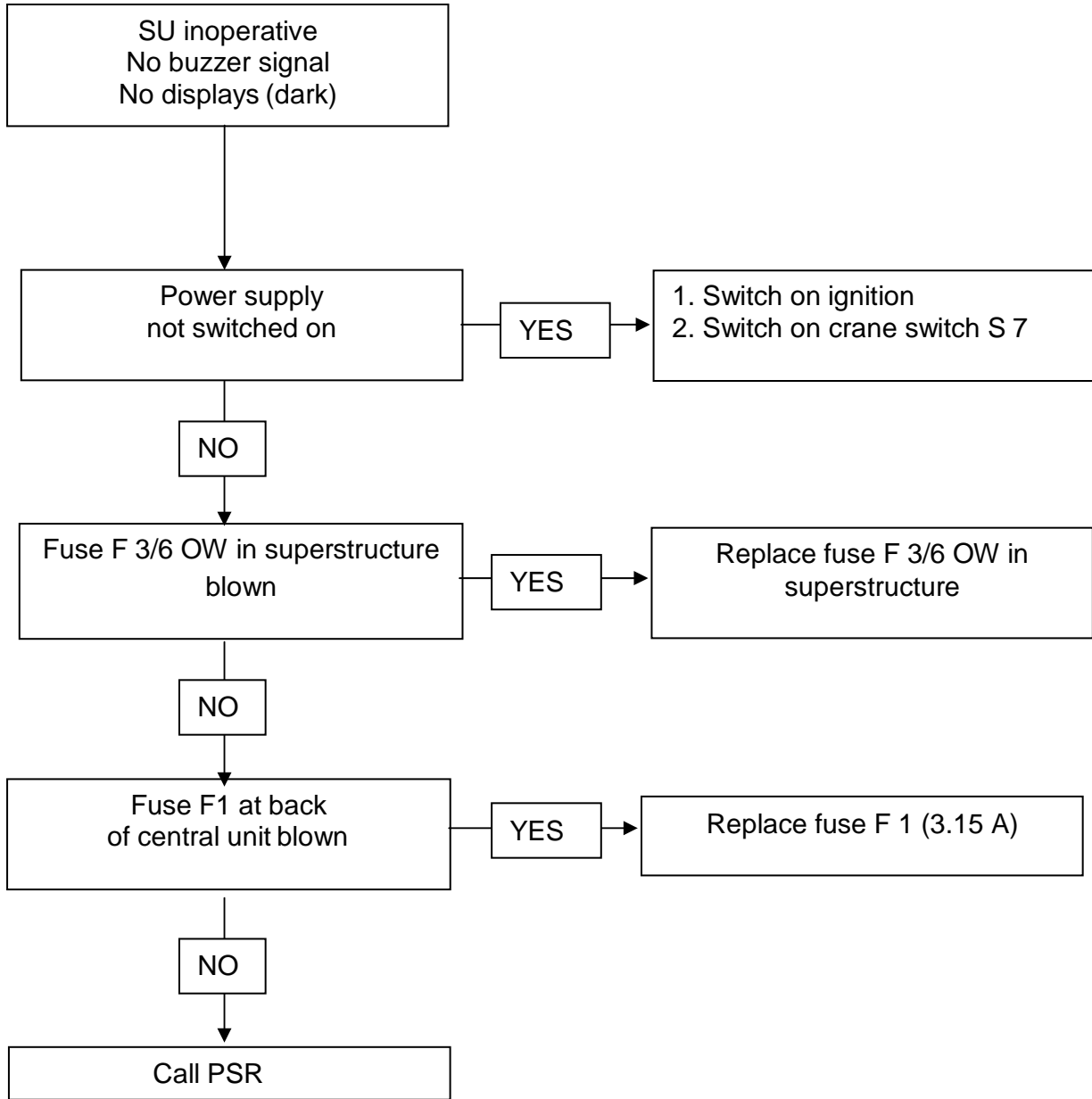

Information display shows letter a:

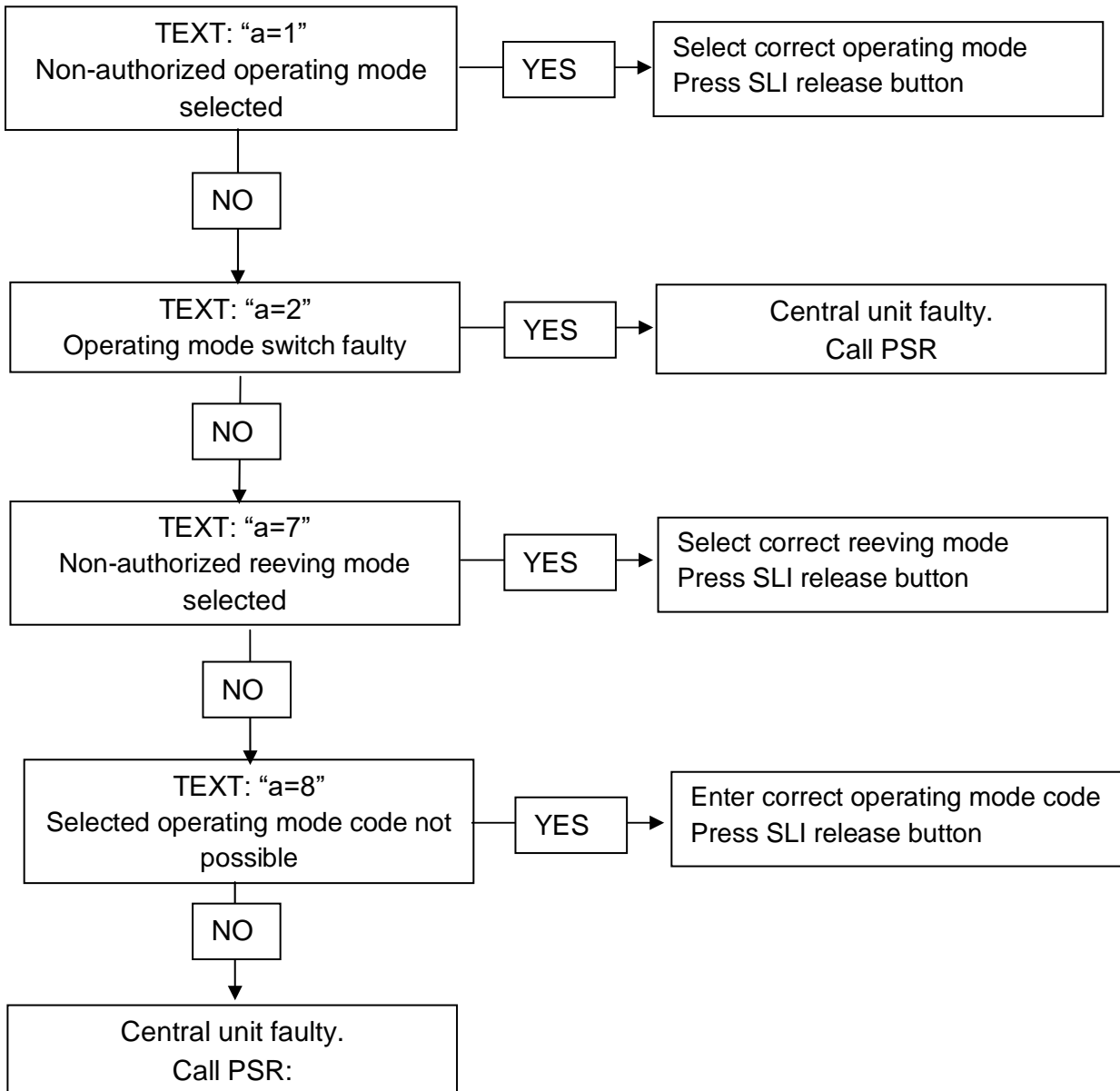

Information display shows letter c:

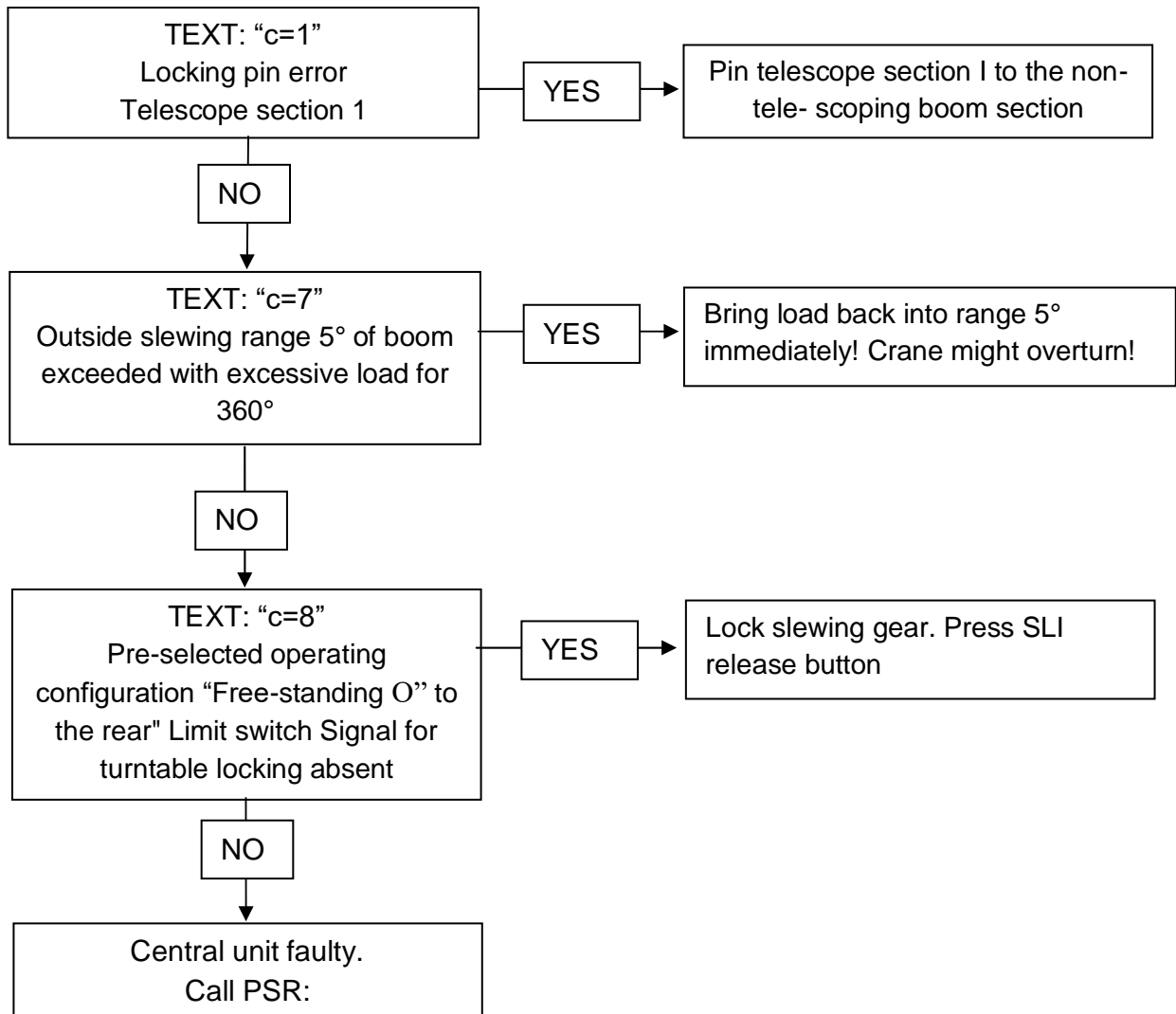

Information display shows letter d:

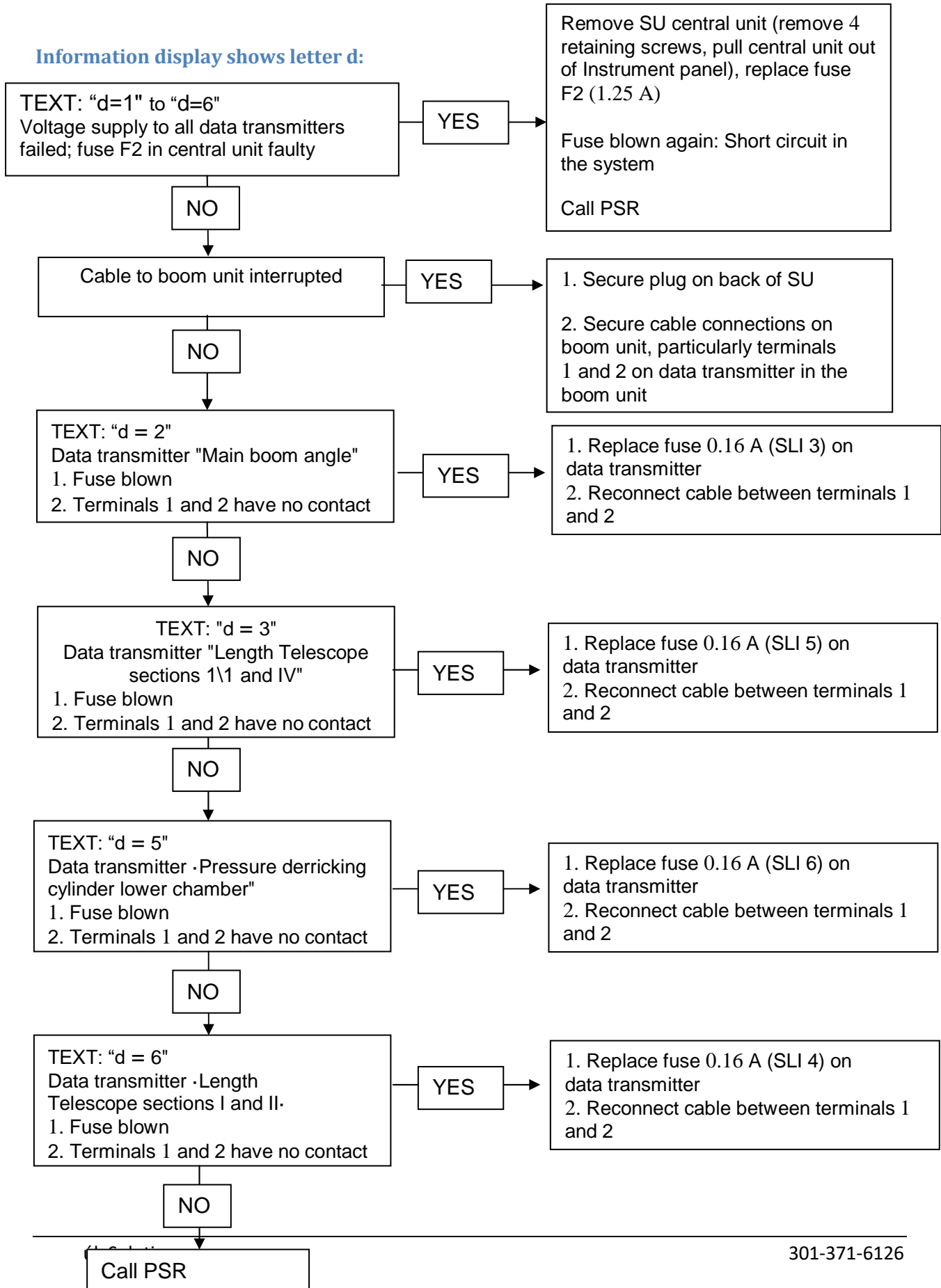

301-371-6126

Information display shows letter e:

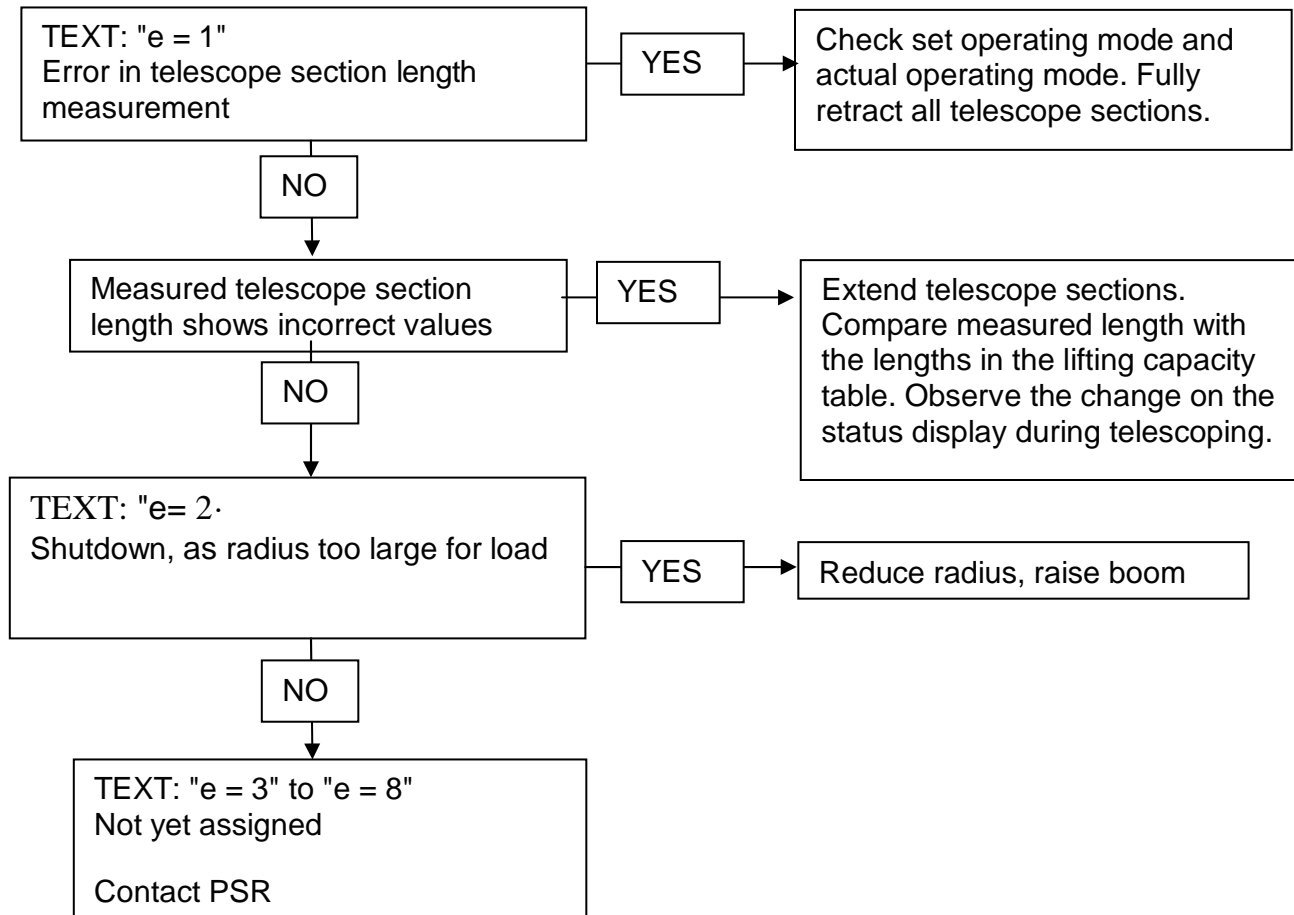

Information display shows letter f:

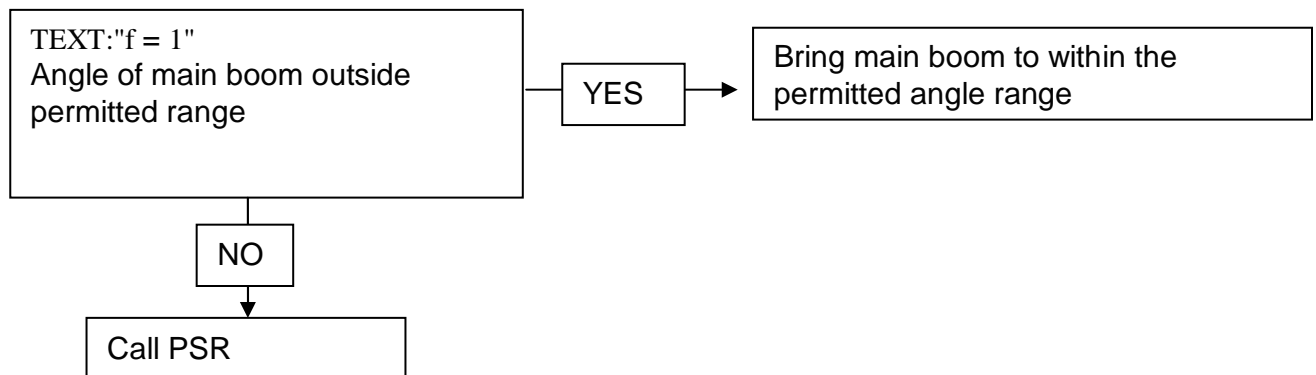

Information display shows letter L, M, or N:

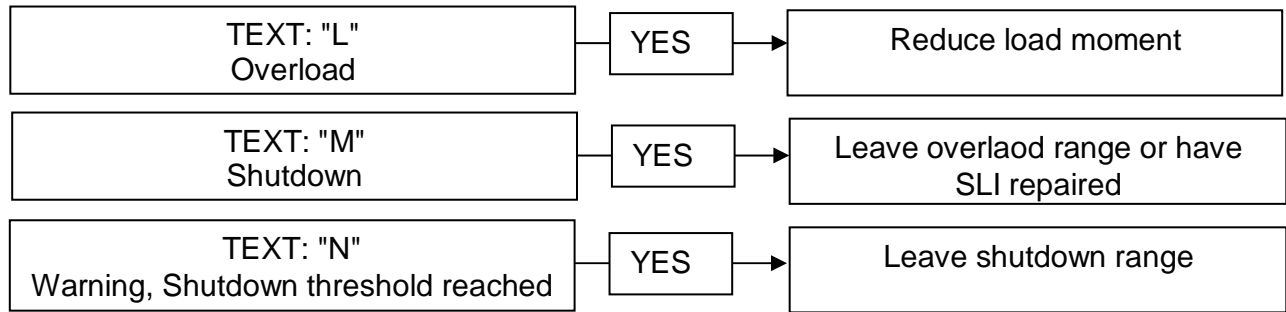

When message L appears all dangerous movements are stopped and movements can only be carried out in the opposite directions.

If the actual radius exceeds the lowest radius Indicated In the lifting capacity tables the following crane movements are stopped

Stopped movements	Permitted movements
Hoist· raising	Hoist· lowering
Lowering the boom	Raising the boom
Extending telescope sections	Retracting telescope sections

If the actual radius is below the lowest radius Indicated In the lifting capacity tables the following crane movements are stopped

Stopped movements	Permitted movements
Hoist· raising	Hoist· lowering
Raising the boom	Lowering the boom
Retracting telescope sections	Extending telescope sections

The message M appears automatically with all of the collective error messages a to f and with message L



DANGER: When any error message appears crane operation must be stopped immediately.

Repairs to the SLI may only be carried out by trained personnel.

Repairs

Checking the data transmitters

Any data transmitter failure is registered by the central unit (the central unit registers the absence of the telegram with the corresponding transmitter identification) and is displayed as a malfunction (shutdown and message “d=.”)

Possible malfunctions:

- Fuse in data transmitter blown: replace
If a second fuse blows:
 - Check pick-up for short-circuit
 - Replace transmitter
- No data bus 24 V voltage supply at terminals 1 and 2
- No or incorrect pick-up voltage supply
 - Pick-up short-circuit
 - Replace transmitter
- Check transmitter identification bridges (terminals 18 to 23)

Identification	Transmitter
1	Derricking cylinder pressure - piston ring surface
2	Angle of main boom
3	Telescoped length of telescope sections III and N
5	Derricking cylinder pressure - piston surface
6	Telescoped length of telescope sections I and II

Incorrect signals can be detected by comparing the actual crane status with the information displayed when the information switch is in the appropriate position.

- Check data pick-ups:
 - Mechanical parts
 - Transmitter connections
 - Transmitter input voltages
- Check transmitter by substitution (e.g. substitute transmitter 'length' by transmitter 'angle1).

Caution! Note transmitter identification.

If these steps do not help in locating the fault and it is necessary to consult Krupp Service it is helpful to be able to describe the problem precisely, and as a result it may not even be necessary for PSR to come out to you. Such a description should address the following points in particular:

1. Exact description of the malfunction
2. Under which conditions (operating modes) does the malfunction occur?
3. What is indicated on the status display?
4. What do the numerical displays "Information", "Radius", "Shutdown value" and "Load" indicate?
1. What does the Information display indicate when the information selector switch is turned to the different positions?

Fuses

Designation	Size (A)	Function (Position)
SLI1	3.15	SLI plug-in module (back plug-in module)
SLI2	1.25	SLI plug-in module (side plug-in module)
SLI3	0.16 (medium time-lag)	Boom angle data transmitter
SLI4	0.16 (medium time-lag)	Data transmitter - Length of telescope sections I and II (boom)
SLI5	0.16 (medium time-lag)	Data transmitter - Length of telescope sections III and IV (boom)
SLI6	0.16 (medium time-lag)	Data transmitter - Piston ring surface pressure (turntable)
SLI7	0.16 (medium time-lag)	Data transmitter - Piston surface pressure (turntable)



CAUTION: Never repair a blown fuse with a nail, wire or silver paper; otherwise the crane may catch fire.

Always replace blown fuses with fuses of the correct size.

Replacing the length measuring cable and setting the length measuring system

Note: After replacement of a damaged or torn length measuring cable, the length measuring system on the cable drum has to be reset.

- Cable drum (1) for the length measuring system of telescope sections I and II. The end of the cable is attached with an anchor clamp to telescope section II.
- Cable drum (2) for the length measuring system of telescope sections III and IV. The end of the cable is attached with an anchor clamp to telescope section IV.

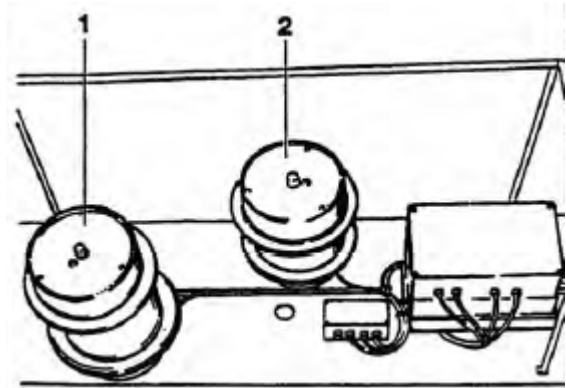

Replacing the length measuring cable

All telescope sections are fully retracted

- Open the terminal box (6) on telescope sections II or IV and remove the cables (5) from the box.
- Remove the anchor clamp (4) from the hook (3).

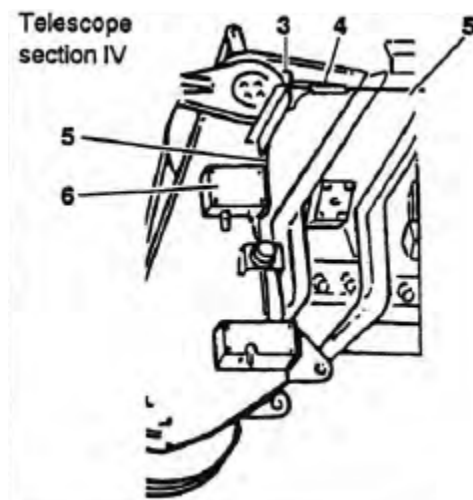
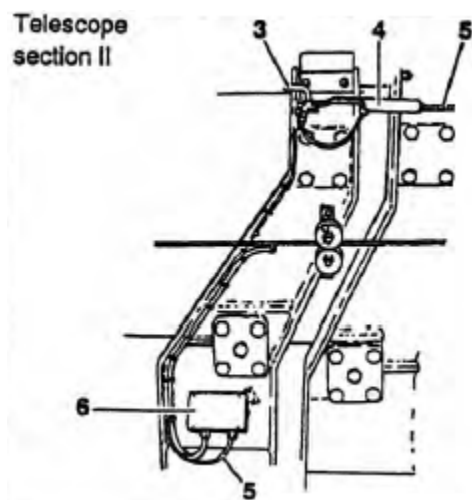

- Push the clamping jaws (7) towards the eyelet (8) and take the cable (5) out of the anchor clamp.
- Unreel the cable from the cable drum (1) or (2).

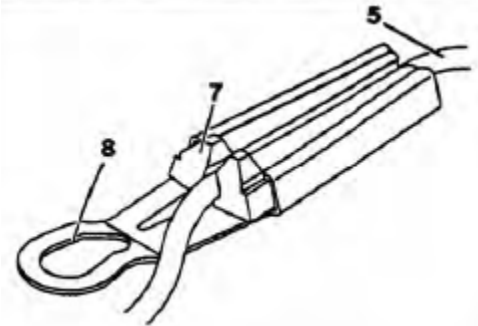

- Unscrew the nuts (10) from the cover of the cable drum.
- Take the cover (11) off the cable drum.
- Detach the cable inside the cable drum and pull it out through the cable opening (9).
- Undo the cable clamps (12) on the drum flange.
- Introduce a new cable through the drum flange and fasten it inside and on the outside of the cable drum.

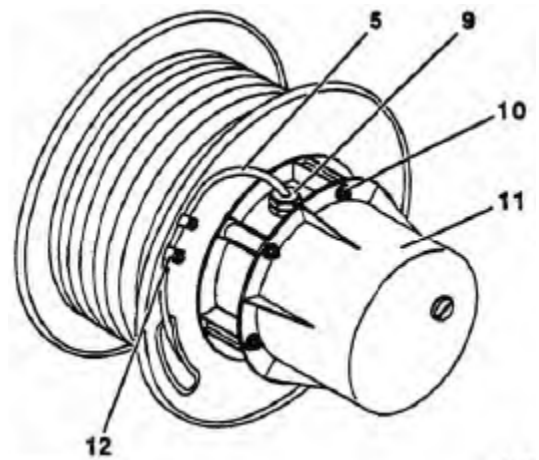

- Reel the entire cable onto the cable drum.
- Turn the cable drum (1) or (2) eight turns to the left by hand and hold it in this position.
- Unreel the cable and pass it through the guide rollers on the telescope sections.
- Attach the anchor clamp approx. 1.5 m from the end of the cable, placing the cable between the clamping jaws and pulling the jaws into the conical part of the anchor clamp.
- Hook the anchor clamp (4) on the hook (3).
- Fasten the end of the cable to the terminal in the box (6). Fasten the cover on the terminal box.
- Fasten the cable between the anchor clamp and the terminal box on the telescope section with cable tying straps.

Checking and setting the length measuring system

- Turn on the ignition in the crane operator's cab.
- Press the release button (15) in the central unit of the SU (13). The SU is now ready for operation.
- Unlock telescope section I.
- Set SLI code to "000". The status display (14) must show telescope status 0-0-0-0.

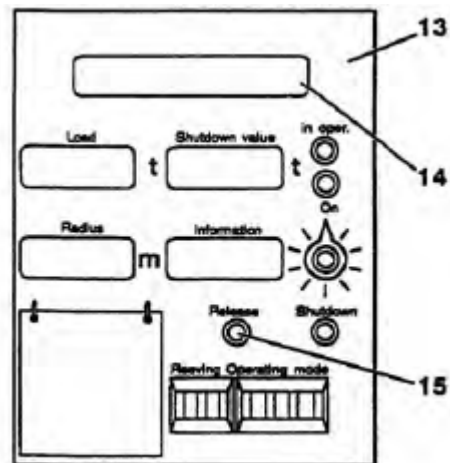

Note: If any other telescope status is displayed, the potentiometer in the length measuring drum must be adjusted.

- Remove the plug (16) from the cover (11).
- Turn the cable drum until you can see the potentiometer (17) through the opening.
- Use a screwdriver to turn the potentiometer (17) completely to the left until the correct 0-0-0-0 telescope status appears on the status display (11).

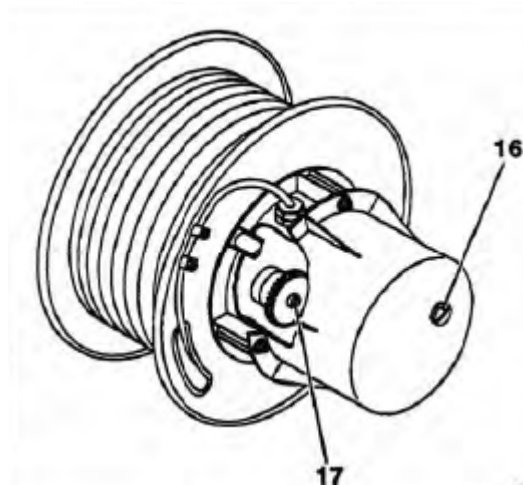

- If the cable on the cable drum (2) has been replaced, extend telescope sections I and II. The status display (14) must show telescope status 100 – 100 – 0 – 0. If this is not the case, adjust the potentiometer (17).
- If the cable on the cable drum (1) has been replaced, extend telescope sections I to IV. The status display (14) must show telescope status 100 - 100 - 100 - 100. If this is not the case, adjust the potentiometer (17).
- After adjusting the potentiometer, refit the plug (16) on the cover.

Technical documents

Wiring Diagram

Length telescope sections III/IV

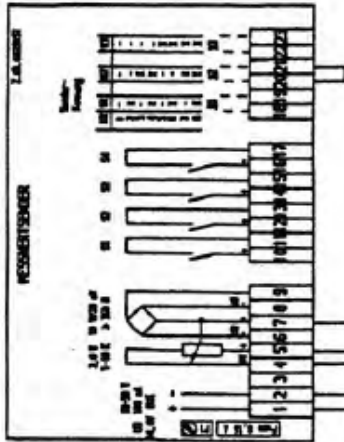

Length telescope sections I/II

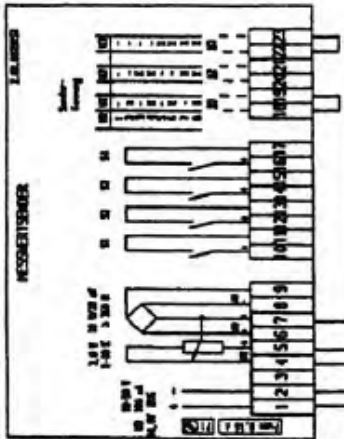

Boom angle

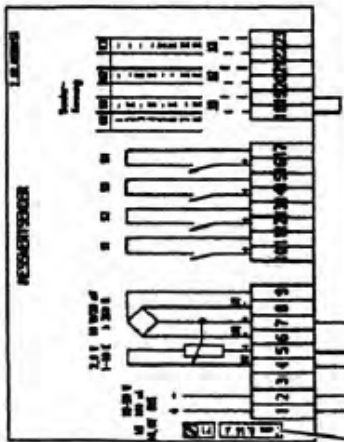

SLI 3

Lifting limit switch

Cable drum
Telescope sections II/III

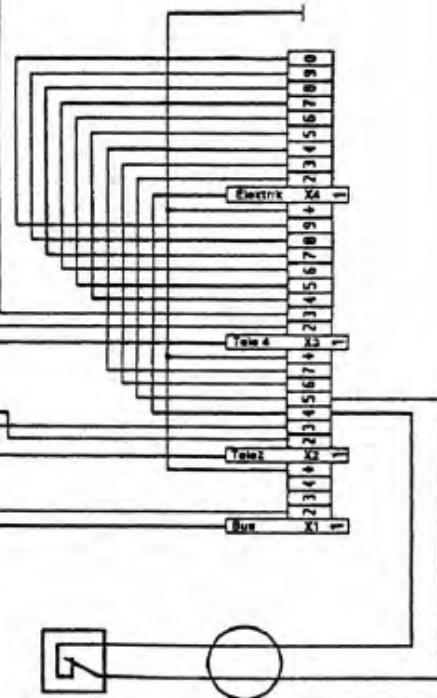

Pressure Transducers

