



www.hirschmann.com

HIRSCHMANN

LOAD MOMENT INDICATOR

mentor



OPERATOR'S MANUAL



PSR Professional Service & Repair Inc.

Professional Service & Repair Inc. is a full-service mobile crane repair, inspection, and certification company. At Professional Service & Repair we understand the critical aspect of your crane being operational to your project schedule and budget. We will deliver world class service to have your crane operational in the minimum amount of time.

PSR is the global provider for sales, repair and installation of Load Moment Indicating (LMI) systems, Anti-Two Block Systems (A2B), and Rated Capacity Indicating systems. Please contact us with your crane repair and certification needs today.

PSR is the name businesses trust for crane repair, inspection, and certification.

Main Line: 706-718-0856

Fax: 706-569-7004

E-Mail: jeff@psrinc.biz

**P.O. Box 6506
Columbus, GA
31917-6506**

NOTICE

Hirschmann, Inc. makes no warranty of any kind with regard to this material, including, but not limited to, the implied warranties of merchantability and/or its fitness for a particular purpose.

Hirschmann, Inc. will not be liable for errors contained in this manual or for incidental or consequential damages in connection with the furnishing, performance, or use of this manual. This document contains proprietary information, which is protected by copyright, and all rights are reserved.

No part of this document may be photocopied, reproduced, or translated to another language without the prior written consent of Hirschmann, Inc.

Hirschmann, Inc. reserves proprietary rights to all drawings, photos and the data contained therein. The drawings, photos and data are confidential and cannot be used or reproduced without the written consent of Hirschmann, Inc. The drawings and/or photos are subject to technical modification without prior notice.

All information in this document is subject to change without notice.

MANUAL REVISIONS

REV	DATE	NAME	DESCRIPTION
-	08/19/05	SB	ECN 05-145, Create manual
A	09/19/05	SB	ECN 05-164
B	01/13/06	SB	ECN 06-005
C	02/20/06	SB	ECN 06-014
D	04/03/06	SB	ECN 06-070

TABLE OF CONTENTS

1	GENERAL INFORMATION	1
2	WARNINGS	1
3	SYSTEM DESCRIPTION	2
	SYSTEM FUNCTION.....	3
	OPERATING CONSOLE.....	4
	LC Display	4
	Control Identification	5
4	SYSTEM OPERATION	9
	LANGUAGE SELECTION	9
	LMI SETUP PROCEDURE	9
	Operating Mode Selection.....	11
	Outrigger Selection Screen	12
	Crane Level Screen	13
	Hoist Selection Screen.....	13
	Reeving (Parts-of-Line) Selection Screen	14
	LIMIT SETTINGS.....	15
5	RADIO ANTI TWO-BLOCK SWITCH (OPTIONAL)	22
	RADIO ANTI-TWO BLOCK TRANSMITTER AND RECEIVER DESCRIPTION	22
	Transmitter / Switch	22
6	PRE-OPERATION INSPECTION AND CALIBRATION VERIFICATION	23
	MACHINES WITH ONLY A MAIN HOIST.....	23
	MACHINES WITH MAIN AND AUXILIARY HOISTS	23
	ANTI TWO-BLOCK RETAINER INSTALLATION.....	24
7	OPERATION	25
8	SERVICE AND MAINTENANCE	26
9	TROUBLESHOOTING	27
	GENERAL	27
	OPERATING ERRORS.....	27
	General Information	1

1 GENERAL INFORMATION

The Hirschmann Load Moment Indicator ¹ (LMI) *mentor* has been designed to provide the crane operator with the essential information required to operate the machine within its design parameters. The LMI provides the operator with information regarding the length and angle of the boom, working radius, rated load and the total calculated weight being lifted by the crane.

The *mentor* LMI basically consists of an operator's console with micro processing unit, length and angle sensor, pressure transducer sensor, and anti-two block switch(es). The system operates on the principle of reference/real comparison. The real value, resulting from the load measurement is compared with the reference data, stored in the central processor memory and evaluated in the microprocessor. If non permitted conditions are approached, the *mentor* LMI will warn the operator by sounding an audible alarm, lighting a warning light and locking out those functions that may aggravate or worsen the crane's condition.

2 WARNINGS

The LMI is an operational aid that warns a crane operator of approaching overload conditions and of over hoist conditions that could cause damage to equipment and personnel.

The device is not, and shall not, be a substitute for good operator judgment, experience and use of accepted safe crane operating procedures.

The responsibility for the safe crane operation shall remain with the crane operator who shall ensure that all warnings and instructions supplied are fully understood and observed.

Prior to operating the crane, the operator must carefully and thoroughly read and understand the information in this manual to ensure that he knows the operation and limitations of indicator and crane.

Proper functioning depends upon proper daily inspection and observance of the operating instructions set forth in this manual. Refer to Section 6. Pre-Operation Inspection and Calibration Verification of this handbook.



WARNING

The LMI can only work correctly, if all adjustments have been properly set. For correct adjustment, the operator has to answer thoroughly and correctly all questions asked during the setup procedure in accordance with the real rigging state of the crane. To prevent material damage and serious or even fatal accidents, the correct adjustment of the LMI has to be ensured before starting the crane operation.

Always refer to operational instructions and load charts provided by the crane manufacturer for specific crane operation and load limits.

¹ LOAD MOMENT: generally the product of a force and its moment arm; specifically, the product of the load and the load-radius. Used in the determination of

3 SYSTEM DESCRIPTION

The Hirschmann Load Moment Indicator *mentor* basically consists of an operator's console with micro processing unit, length and angle sensor, pressure transducer sensor, and anti-two block switch(es).

The system operates on the principle of reference/real comparison. The real value, resulting from the load measurement is compared with the reference data, stored in the central processor memory and evaluated in the microprocessor. When limits are reached, an overload warning signal is generated at the operator's console. At the same time, the crane functions, such as hoist up, boom down and telescoping out will be stopped.

The fixed data regarding the crane, such as capacity charts, boom weights, centers of gravity and dimensions are stored in memory chips in the central processor unit. This data is the reference information used to calculate the operating conditions.

The length/angle sensors inside the cable reel, which is mounted on the boom, measure the boom length and angle. The boom length is measured by the cable reel cable that also serves as an electrical conductor for the anti two-block switches.

The crane load is measured by pressure transducers attached to the piston and rod sides of the lift cylinder.

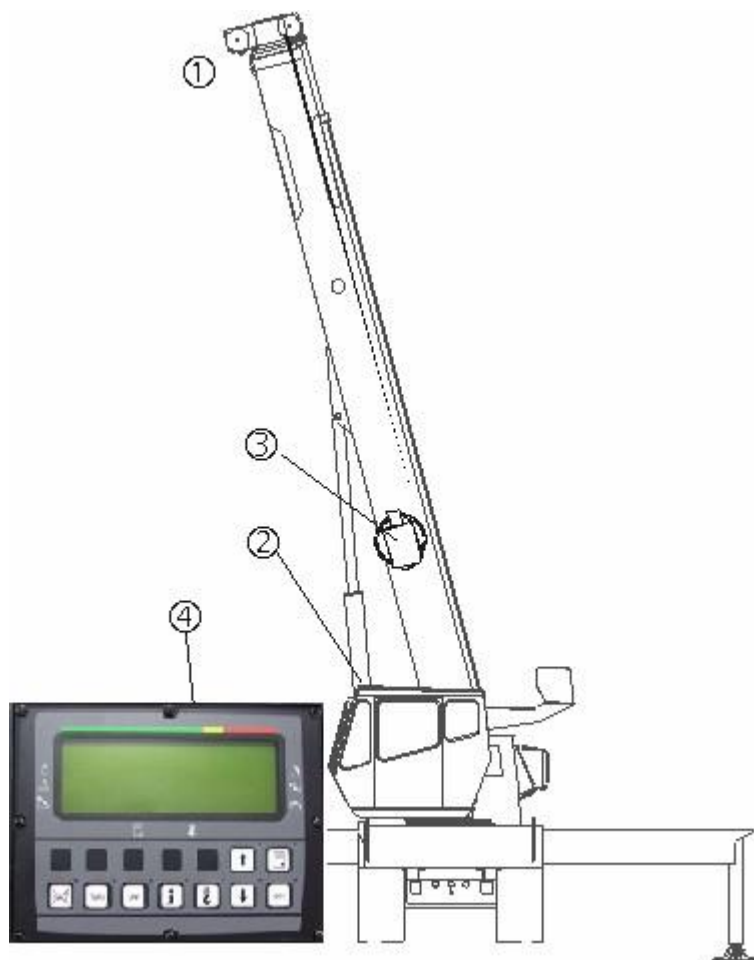

1. A2B Switch(-es)
2. Pressure Transducers
3. Cable Reel
4. Console

Fig. 1: Components of the LMI System Mentor

SYSTEM FUNCTION

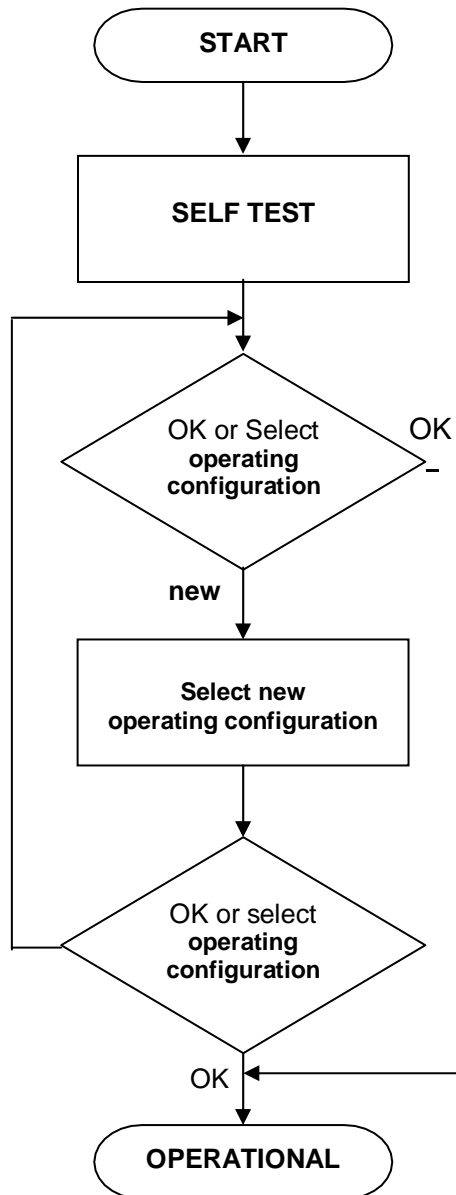

Upon switching on crane ignition switch, the system starts with an automatic test of the LMI system. During the test, the LC Display shows the crane model and serial number.

The last selected operating mode will be displayed and must only be confirmed OK if that configuration setup equals the crane's actual configuration. Otherwise it must be deleted to enter a new configuration. (⇒ chapter 4)

When operating in the Manbasket configuration the system will default to the previously selected Manbasket operating screen, eliminating the need for the operator to acknowledge the configuration from the cab. (⇒ chapter 4)

The operating configuration is determined by selecting from a list of possible operating configurations. (⇒ chapter 4)

The configuration setup entered will be displayed and the reeving (parts-of-line) must be entered. (⇒ chapter 4)

Upon acknowledgment of the inputs the system is ready for operation.

OPERATING CONSOLE

The console has 3 functions:

- **inputs by the crane operator (operating configuration, reeving, and calibration)**
- **input of geometry limit values and signalization of exceeded limit values**
- **display of important data and information**

The operator's console is mounted in the operator's field of vision. For a better identification of displays and operating elements, they are continuously backlit during operation.

LC Display

The LC display (LCD) used in the Hirschmann mentor operator's console is a wide temperature-range alphanumeric display with transfective characteristics that give it a high visibility in sunlight and during backlit night operation. Due to the nature of any LCD, it works on the principle of polarization of light. It should be noted that dual polarizations that are at a certain angle to each other can reduce the amount of light up to completely eliminating it if that angle becomes perpendicular. This can have significance if the operator is wearing polarized sunglasses that happen to be perpendicularly polarized in relation to the LCD's polarization. In this rare case, the operator has to work without sunglasses or find different sunglasses that do not have this characteristic, in order to avoid having the visibility of the display impaired.

The LCD contains an automatic temperature compensation that will adjust the LCD's contrast according to the surrounding temperature.

Control Identification

This unit contains a display and different controls that are described as follows:



Fig 2: Operator's Console

* *Optional by-pass warning lights activated upon customer's installation of override keyswitch.*

1. LCD Area
2. Load Moment Prewarning Light
3. Load Moment Limit Light
4. Alarm Light "Anti-Two-Block"
5. * "BY-PASS LMI Lock-out" Light
6. * "BY-PASS Anti-Two-Block" Light
7. Button "SCROLL UP"
8. Button "SELECT OPERATION MODE"
9. Button "Alarm Stop"
10. Button "Tare"
11. Button and Control Light "LIMITS"
12. Button "info"
13. Button "REEVING (Parts-Of-Line)"
14. Button "SCROLL DOWN"
15. Button "OK"

1 LC-Display



The LCD visualizes texts and numerical values:

- | | |
|-------------------------|-----------------------------|
| 1. Load Moment Bargraph | 6. Reeving (Parts-Of-Line) |
| 2. Actual Load | 7. Tip Height |
| 3. Capacity (Max. Load) | 8. Boom Length |
| 4. Load Radius | 9. Boom Angle |
| 5. Operating Mode | 10. Main /Aux. Hoist Option |

2 Load Moment Pre-warning Light



The yellow LOAD MOMENT PRE-WARNING LIGHT (2) will light up when the load on the crane reaches the defined pre-warning area, thus indicating that an overload condition is approaching.

This means for the operator to continue his crane operation with extreme caution.

3 Load Moment Limit Light



The red LOAD MOMENT LIMIT LIGHT (3) warns the operator that a rated load condition has been reached. It lights up when the load on the crane reaches the crane load capacity. The audible alarm also sounds when this condition has been reached.

The following crane movements will be stopped concurrently:

- **Hoist up**
- **Boom down**
- **Telescope Out**

Crane lockouts are dependent on crane models, if lockouts do not function as described refer to crane manufactures documentation.

4 Alarm Light "Anti Two-blockl"

The red "Anti Two-Block Alarm Light" lights up when the anti-two-block limit switch contacts open, indicating that a two-blocking condition is approaching. At the same time the audible alarm will sound.

The following crane functions will be disabled subsequently: hoist up, telescope out, and boom down (refer to *mentor* service manual or the crane owner's manual for a complete description of the anti-two-block system).

5 LMI Override Key Warning Light

The red LMI OVERRIDE WARNING LIGHT flashes to indicate that the LMI cut-off function is activated. This is activated by an external bypass key switch (supplied by customer).

6 A2B Override Key Warning Light

The red A2B OVERRIDE WARNING LIGHT flashes to indicate that the A2B cut-off function is activated. This is activated by an external bypass key switch (supplied by customer).

**WARNING**

Since lights (5) and (6) indicate the deactivation of the kick-out function of the LMI system and the anti two-block system, the following instructions must be obeyed:

- The optional override by-pass key switch function shall be used with discretion, as unwarranted use of it to override the control lever lockout system can result in harm to the crane and danger to property and persons.
- Never use the optional override by-pass key switch function to either overload or operate the crane in a non-permissible range.

7 Button "SCROLL UP"

Use this button to increase values or to scroll up.

8 Button "SELECT OPERATION MODE"

Use this button to start the function "set operating mode".
For the proceeding please refer to ⇒ chapter 4.1.



The correct setting is of utmost importance for the proper function of the system and the crane. Therefore only operators who are thoroughly familiar with use and operation of the system shall set this button.

9 Button "Alarm Stop"



This ALARM STOP BUTTON allows for the audible alarm to be silenced for approximately 15 seconds by pressing this button.

10 Button "Tare"



The button "TARE" is used to indicate the "Net load" on the LCD. Net load is the present load, less lifting tackle and hook block. The Tare Button has to be activated *before* lifting. After pushing the "Tare Button" the load display flashes and is set to zero (taring). After lifting a load the display shows the *net load* (pay load). The *net load* display will change to the actual load display when the boom radius is changed (either by angle or length).

11 Button "LIMITS"



Button to start the function "program limit values".
For the proceeding please refer to ⇒ chapter 5.1.

12 Button "info"



Use this button to access screens that give additional information.

13 Button "REEVING (Parts-Of-Line)"



Button to start the function "select parts of line"
Please refer to ⇒ chapter 4.2.

14 Button "SCROLL DOWN"



Use this button to decrease values or to scroll down.

15 Button "OK"



Use this button to confirm settings.

4 SYSTEM OPERATION

The LMI setup procedure allows the operator to input the crane configuration. The operator must complete the configuration setup procedure for the Load Moment Indicator system by confirming (pressing OK) to set the system into operation or changing it to enter a new configuration. The previous configuration setup will be displayed and must match the current crane operating configuration.

LANGUAGE SELECTION

The *mentor* has 4 language selections available to the operator: English, Spanish, German, and

French. From the normal operating screen, press the  button to active language selections.



LMI SETUP PROCEDURE

If the system is turned off, all adjustments remain stored. When turning the system on again these adjustments can be acknowledged by merely pressing the OK button (provided that the crane configuration has not been modified!).

** When operating in the selected Manbasket configuration, all adjustments will remain stored after the system is turned off. Only when operating in the Manbasket configuration will the system default to the previously selected Manbasket operating screen, eliminating the need for the operator to acknowledge the configuration from the cab.*

During the programming procedure the Load Moment Prewarning Light (2), Load Moment Limit Light (3), and the Anti two-block Alarm Light (4) will light up and the crane functions will be interrupted.

Note: *If a configuration is selected which is not available, the display will indicate error code E04. In this case, the procedure has to be repeated with valid values!*



The correct setting is of utmost importance for the proper functioning of the system and the crane. Therefore, only operators who are thoroughly familiar with the crane and the operation of the system should execute the setting of the system according to the operating configuration of the crane.

The LMI programming procedure consists of the following steps:

- **set the operating mode (crane configuration)**
- **select the outrigger configuration**
- **verify crane is level**
- **select the hoist in use (for machines with dual hoist option)**
- **select the reeving (parts-of-line)**

For easy operation, the computer guides the operator through the procedure step by step. (Interactive operation)

Operating Mode Selection

...starts:

- **Manually** after each modification of the crane configuration by pressing "SELECT OPERATION MODE" (8) button.

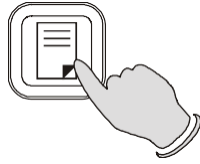

A screen similar to the following one will appear:

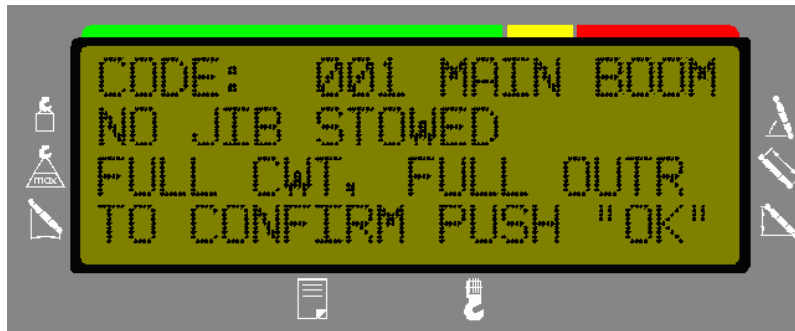

If this operating mode corresponds with the current machine configuration, press .

Otherwise, use the scroll buttons  and  to scroll between the possible operating modes (configurations) of your machine.

When you have found the operating mode that corresponds with the current machine configuration, press . This will automatically bring you to the ...

Outrigger Selection Screen

A screen similar to the following one will appear for the outrigger selection.

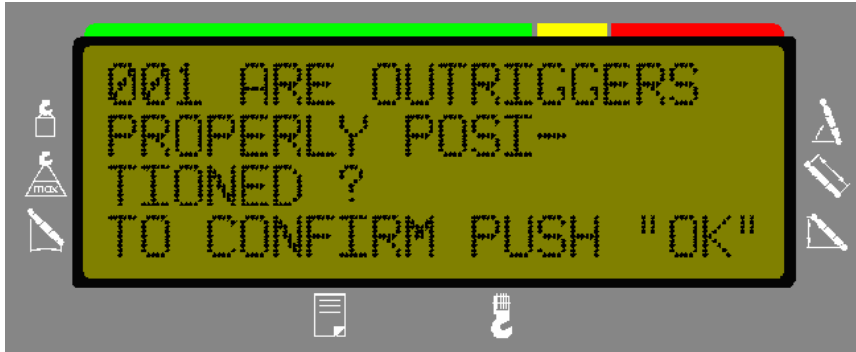

If this outrigger selection corresponds with the current machine configuration, press .

Otherwise, use the scroll buttons  and  to scroll between the possible outrigger selections for your machine.

When you have found the outrigger selection that corresponds with the current machine configuration, press .

Crane Level Screen

A screen similar to the following one will appear verifying if the crane is level.

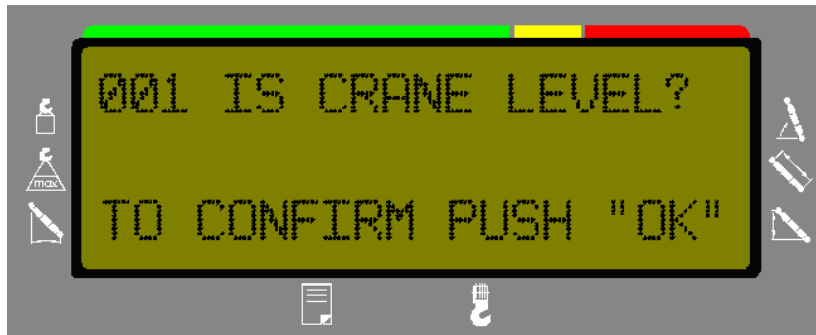

If the crane is level, press . If the crane is not level to manufacturer's specification, refer to manufacturer manual, then level crane to specifications.

Hoist Selection Screen

A screen similar to the following one will appear if you have a second hoist option

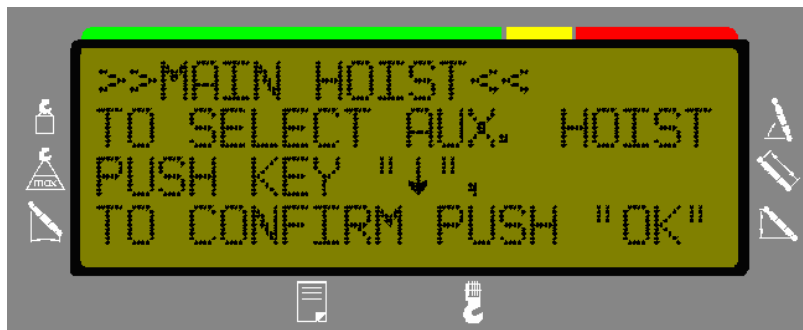

Use the scroll buttons  and  to toggle between auxiliary and main hoist.

When you have selected the hoist that corresponds with the current machine configuration, press . This will automatically bring you to the ...

Reeving (Parts-of-Line) Selection Screen

...starts:



- *Manually* by pressing "REEVING "(13) button, if the machine is **not** equipped with a dual hoist option.

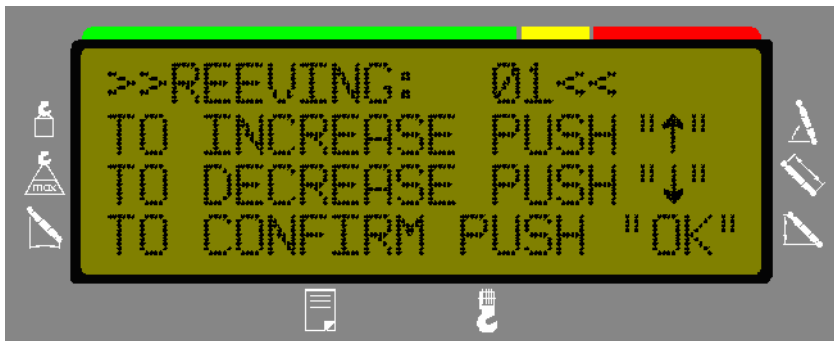

- *Automatically* after selecting the hoist, if the machine **is** equipped with a dual hoist option.

A screen similar to the following one will appear:



Use the scroll buttons  and  to increase or decrease the number of parts of line until it matches the current reeving of your machine.

When you have selected the correct reeving, press .

This concludes the setting of the reeving and/or operating mode. If you have selected a valid operating mode, the system will bring you back to the operating screen. If you have selected an invalid operating mode, the system will show an E-04.

LIMIT SETTINGS



The operator has the option to activate a maximum and minimum geometric limit for boom angle, radius, and boom tip height. When a limit is activated, the working screen will display, an 'R' in front of the radius indication, 'H' in front of the tip height indication, 'A' in front of the angle indication, 'S' in front of the slew angle indication, and a 'W' to indicate the virtual wall limit. When the limit is exceeded the system will alert the operator by sounding an audible alarm, lighting the horn silence button, and flashing the letter 'R', 'H', 'A', 'S', or 'W' on the display. There is no cutout associated with the limit function. Use the following procedure to set or delete a limit.

After pressing the limit button , the following screen will appear indicating all current limits. If no limits have been set, the system will advance to the individual limit setting selection screen.







R Radius
H Tip Height
A Angle
S *Slew Angle
W *Virtual Wall

* Options which require special hardware i.e. slew potentiometer

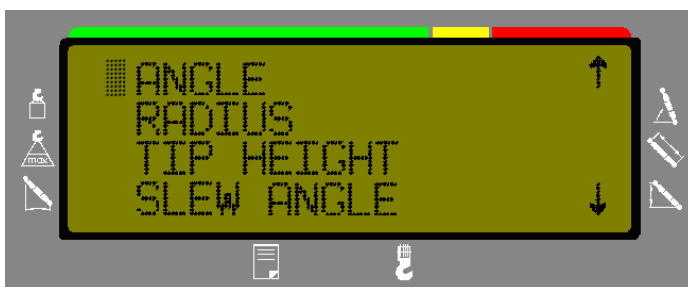
The upper left corner of the display will indicate only limits that have been set. Use the  and  arrow buttons to scroll through the set limits.



Press the  button to proceed to the individual selections:



Use the  and  arrow buttons to select the limit to be set or deleted; the selection should now be flashing. Then press .

➡ **Angle limit setting: The following screen will be displayed**



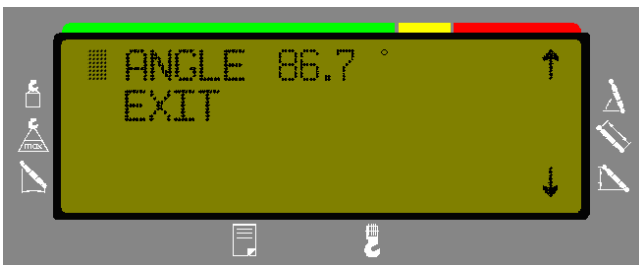
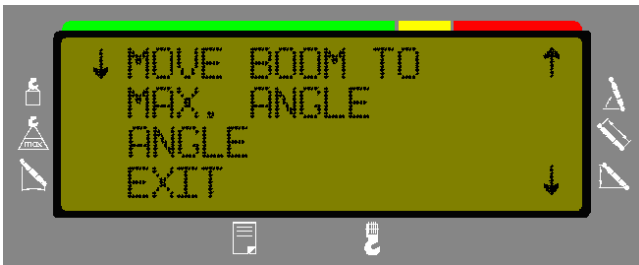

Use the  and  arrow buttons to select the maximum/minimum angle, delete angle limits, or exit limit function. Then press .



Only one of the functions MIN/MAX can be completed at a time.



MIN. Limit: Boom to the minimum angle and press .

MAX. Limit: Boom to the maximum angle and press .

Use the  and  arrow buttons to select another angle limit or exit the angle limit function.

➤ radius limit setting: The following screen will be displayed



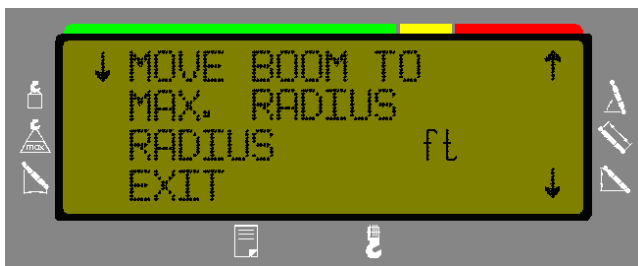

Use the  and  arrow buttons to select the maximum/minimum radius, delete radius limits, or exit limit function. Then press .



Only one of the functions MIN/MAX can be completed at a time.



MIN Limit: Boom to the minimum radius and press .

MAX. Limit: Boom to the maximum radius and press .

Use the  and  arrow buttons to select another radius limit or exit the radius limit function.

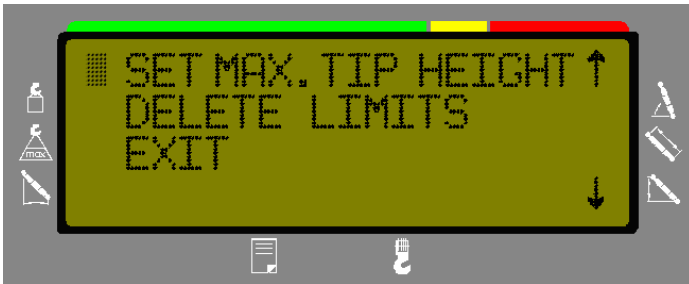
➡ **Tip height limit setting:** The following screen will be displayed





Use the  and  arrow buttons to select the maximum tip height, delete tip height limits, or exit limit function. Then press .



MAX. Limit:
Boom to the maximum tip height and press





Use the  and  arrow buttons to select another tip height limit or exit the tip height limit function.

➤ **Slew Angle limit setting:** The following screen will be displayed

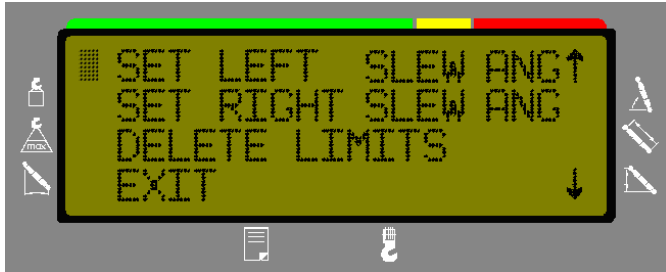
Note: *Slew Limits are an option that will not be available with all cranes.*



Use the  and  arrow buttons to select the left slew angle, right slew angle, delete slew angle limits, or exit limit function. Then press .





Only one of the functions LEFT/RIGHT can be completed at a time.

LEFT Slew Angle Limit:

Boom to the minimum radius and press .

RIGHT Slew Angle Limit:

Boom to the maximum radius and press .

Use the  and  arrow buttons to select another radius limit or exit the radius limit function.

➤ Virtual Wall limits setting:

Note: Virtual Wall Limits are an option that will not be available with all cranes.

The *Virtual Wall* setting helps the operator to define the crane's working area. This is done by creating a vertical wall that can represent obstacles (i.e. buildings, towers, poles, etc.) in the crane's working range. The wall is set by defining points with the boom tip along the outer limits of the operator's work area, see setup procedure below. Because these walls are defined by the operator and are not "actual real" walls, we refer to them as "*virtual*" walls.

When setting a wall, always keep a safe working distance to any obstacles. Never work outside a safe working area as outlined by common practice, standards, and manuals.

A *virtual wall* is set by defining two points. To prevent inaccuracies when defining the two points of the virtual wall, use the following two rules:

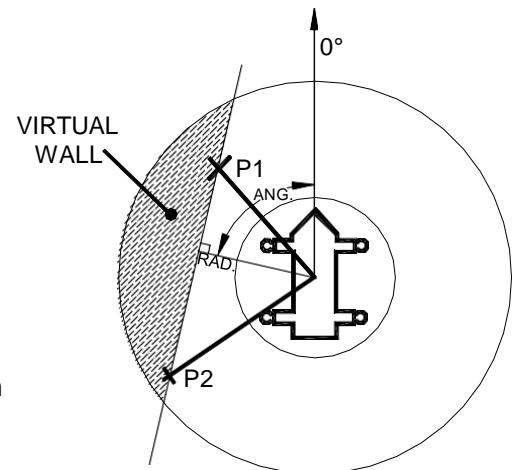

1. The two points should be the same distance from the obstacle.
2. Set the two points at the maximum distance apart, which can be safely reached by the boom tip.

A virtual wall is defined by a straight line between two set points. After the wall has been set, the system alerts the operator when the boom approaches it. This is done both visual and audible. The console will warn the operator by an audible, beeping alarm as the boom approaches the wall. At the same time, the "LIM" button will be lit. Similarly, the "*virtual wall*" symbol in the main screen blinks. If the boom breaks the plane of the wall, the audible alarm becomes continuous. See the Pre-warning System Section for information on how the pre-warning system is defined.

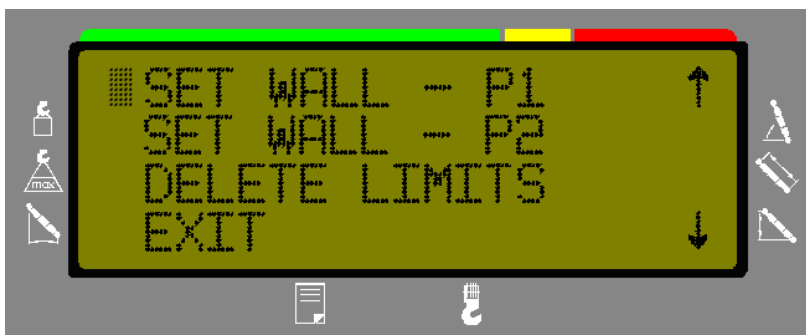

➤ Virtual Wall limit setting: The following screen will be displayed



Use the  and  arrow buttons to select the virtual wall P1, virtual wall P2, delete virtual wall, or exit limit function. Then press .





Only one of the functions P1/P2 can be completed at a time.

Select Virtual Wall P1 and press .

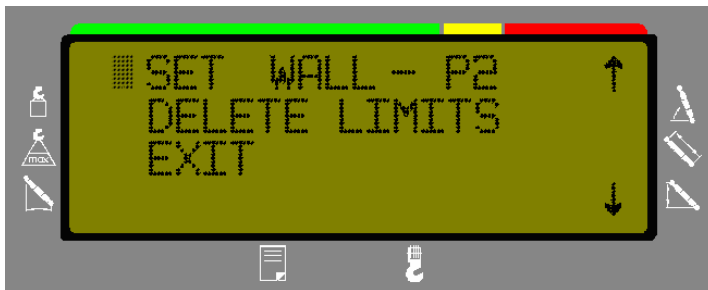

By moving the boom, select the first point of the virtual wall location and press .



Select Virtual Wall P2, then press .



Boom to the selected second point of the virtual wall location, and press .

Use the and arrow buttons to select another limit or exit the virtual wall limit function.

5 RADIO ANTI TWO-BLOCK SWITCH (OPTIONAL)

RADIO ANTI-TWO BLOCK TRANSMITTER AND RECEIVER DESCRIPTION

The anti-two block system alerts to an impending two-block condition. This alert can come in the form of an audible alarm and visual LED on the console face or with the optional function lockout if the crane is so equipped.

The PAT Radio Anti Two Block uses radio communication electronics that transmits an OK signal. This is to ensure accurate and consistent reception of data and to reduce the possibility of unnoticed failure. The Unique, serialized transmitter identifiers are used to ensure proper operation even though other cranes are in the area.

Transmitter / Switch

Transmitter LED:

The transmitter has an LED on the bottom for diagnostics. The LED should be on when in a two-block condition or when the weight is lifted. The LED will flash rapidly during a 2-block condition and will stop flashing after the switch is in a two-block condition for more than 15 seconds. The LED will flash randomly approximately every 4.5 seconds when the switch is transmitting. When in sleep mode, the LED will not flash.



Storage of the A2B transmitter for Travel:

The weight should remove from the switch when traveling to extend battery life. The system is in permanent lockout and the system will not function until the chain is unhooked. To use the feature, attach any part of the chain into the hook. When it is desired to use the switch again, simply unhook the chain to allow the switch to close.

Battery Level Monitoring:

When the transmitter's voltage level drops to 3.9 volts (with approx. 10% battery life remaining), a low battery warning will appear on the operating screen. Replace batteries at the next convenient opportunity.

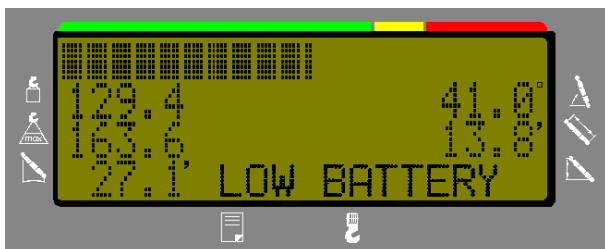

6 PRE-OPERATION INSPECTION AND CALIBRATION VERIFICATION

Before operating the crane, the following electrical connections must be checked to ensure that the system is properly connected for the crane configuration.

MACHINES WITH ONLY A MAIN HOIST

If the crane works only with the boom and without boom extension, no additional connections are necessary. However, be sure the weight of the anti two-block switch is properly installed on the main hoist load line. With even parts of hoisting line, the weight shall be attached to the dead-end line. With odd parts of hoisting line, the weight shall be attached to the line of lowest speed.

If the crane works with boom extension, the connecting cable shall be installed between the junction box on the boom extension and the boom junction box. The weight attached to the main hoist anti two-block switch shall be removed. In that case the anti two-block switch has to be locked with the red Anti Two-Block Retainer, which is fixed with a red lanyard at the anti two-block switch (described in the following pages). Then the weight shall be reattached to the boom extension anti two-block switch.



Failure to re-position the anti two-block switch weight will prevent the overhoist system from functioning properly. No weight shall be on the main hoist anti two-block switch when the boom extension is being used.

MACHINES WITH MAIN AND AUXILIARY HOISTS

If the boom extension is not in the operating position, the by-pass plug shall be installed in the main boom junction box. The weight of the main hoist anti two-block switch shall be installed.

If the boom extension is in the operating position, the connecting cable shall be installed between the junction boxes on the boom extension and the main boom. Weights shall also be attached to the anti two-block switches on both the main boom and boom extension.

If the boom extension is in the operating position and no load line is being used on main boom, to prevent injury or damage to equipment, the weight shall be removed from main boom switch. In that case the anti two-block switch has to be locked with the red Anti Two-Block Retainer, which is fixed with a red lanyard (not shown) at the anti two-block switch.

ANTI TWO-BLOCK RETAINER INSTALLATION

Installation of Anti Two-Block Retainer in Locking Position Procedure (see Fig. 1 and 2):

1. Pull the cable out of the switch and bend back parallel to the boom and hold (1).
2. Slide the retainer from left side with its slot over the cable between the crimped stop and the switch (2). Push it firmly straight onto the cable guide of the Anti Two-Block switch (3).

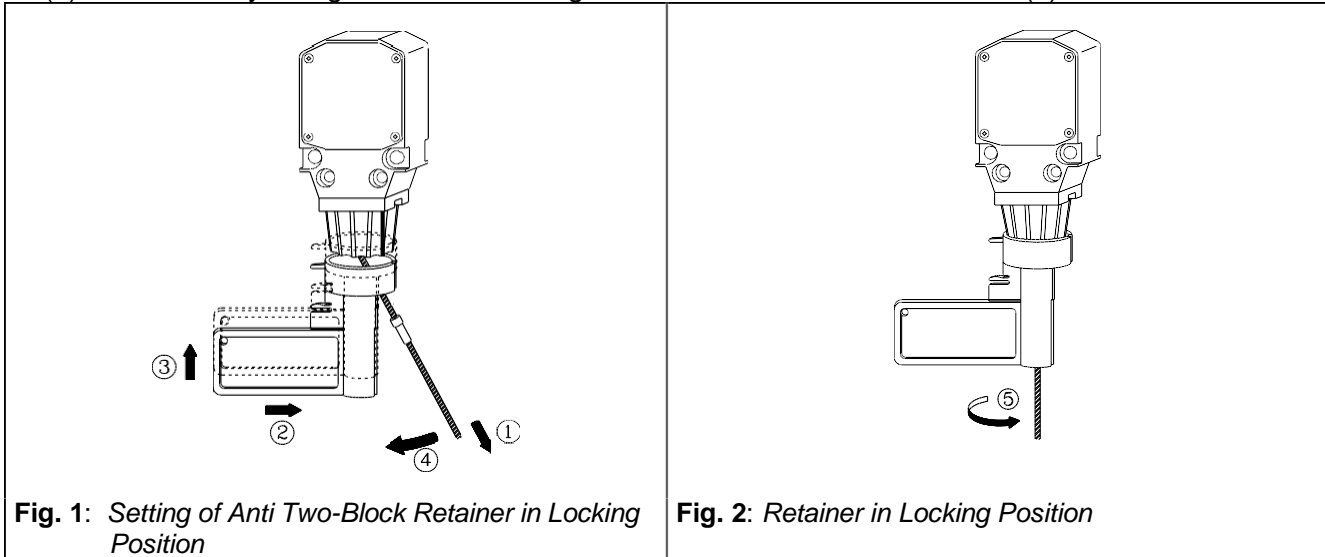

3. Straighten the cable completely into the slot and release the cable (4).
4. Turn the flag of the retainer for best visibility for the operator (5).

Removal and Storage of the Anti Two-Block Retainer Procedure (see Fig. 3 and 4):

1. Pull the cable out of the switch (1) and bend back parallel to the boom and hold (2).
2. Move the retainer down (3) and then left (4) to remove it from the Anti Two-Block switch. Release the cable.
3. For storage slide the retainer from right side (5) over the Anti Two-Block switch until the clips (A) lock into the holes (B).

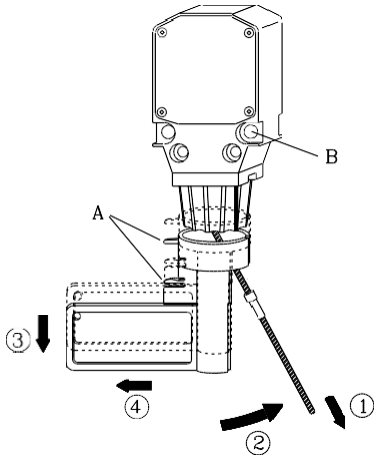

Fig. 3: Removal of the Anti Two-Block Retainer

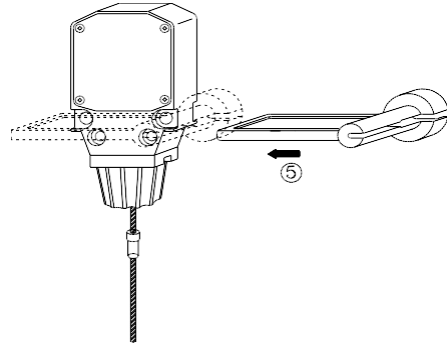

Fig. 4: Retainer in Storage Position

7 OPERATION

Upon correct inspection the LMI is operational. The operator shall be thoroughly familiar with all controls of the LMI before operating the crane. The proper function of the system shall be checked by lifting a load of known weight and comparing the load to the information displayed on the LMI.

Rated loads include the weight of the hook block, slings, and auxiliary load handling devices. Their combined weights shall be subtracted from the listed load capacities as stated on the load capacity chart to obtain the net load to be lifted.



If any of the displays reflects a deviation between displayed and actual values, an authorized Hirschmann service representative shall be called for repair of the system or re-verification of the crane's LMI calibration.

Any structural modifications or changes to the crane shall require re-verification of the crane's LMI calibration.

8 SERVICE AND MAINTENANCE

Daily maintenance of the Load Moment Indicator consists of inspecting:

1. The electrical wiring connecting the various parts of the system.
If electrical wiring is damaged, it shall be replaced immediately.
2. If the insulation is worn on the electrical wiring or cable guides are damaged, these parts shall be replaced.
3. Check the anti two-block limit switches for freedom of movement.

Other than correcting the problems identified in the Malfunctions Table and replacing faulty mechanical parts and cables, no other repairs shall be performed by non-expert personnel.

When the LMI system is turned on, it will go through a self-test. During this time, the console will display the following screen and scroll from 1-6 while loading the system information:

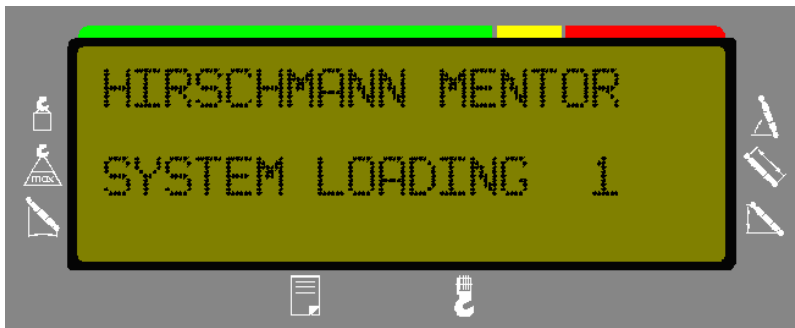

Make sure the display is working and all the lights come on during this time. If any of the components above fails, please contact you're nearest service representative before operating the system!

9 TROUBLESHOOTING

GENERAL

In case of a malfunction of the system, the display (1) will indicate a code that identifies the system malfunction.

The error codes listed in the Malfunction Table will identify various faults that can occur with the LMI. The Table explains each fault and describes the action which shall be taken to correct the fault. Faults within the electronic microprocessor shall be repaired by factory trained service personnel. When these faults occur, the competent service organization shall be contacted.

OPERATING ERRORS

Malfunctions in the system, which are caused by, range exceeding or operating errors by the crane operator himself are indicated on the display together with an explanation. Error codes E01, E02, E03, E04, and E05 can normally be eliminated by the crane operator.

Error Code	Cause	Elimination
E01	Fallen below the minimum radius or above the angle given in the load capacity chart due to luffing up the boom too far.	Refer to Load Chart. Boom down to a radius or angle given in the load capacity chart.
E02	The maximum radius or minimum angle given in the load capacity chart was exceeded due to luffing down the boom too far.	Refer to Load Chart. Boom up to a radius or angle given in the load capacity chart.
E03	Boom position is out of the permissible working area (over front).	Move boom back to the permissible working area. See lifting diagram in the load capacity charts.
E04	Operating mode in the console incorrectly set.	Correctly set operating mode to the code assigned to the operating mode of the crane.
	Operating mode is not permissible with the actual crane configuration, boom position or area definition.	Be sure crane is set up according to proper operating configurations.
E05	Prohibited length range	Refer to Load Chart. Extend/retract boom to the correct length
EAB	Short circuit in the A2B switch circuit (not with radio A2B)	Replace A2B switch or cable to the A2B switch.
EAD	No valid A2B switch status	Replace A2B switch or cable to the A2B switch. Replace battery of radio module (radio A2B). Setup ID in DGA12.9.
E1A	Fallen below lower limit value in measuring channel "slewing angle 1". Slew below allowed range.	Cable between the central unit and the slewing angle sensor defective or loose. Water inside the plug of the angle sensor. Move to allowed slew range. Replace slewing angle sensor or sensor unit.
E1B	Fallen below lower limit value in measuring channel "slewing angle 2"	Refer to E1A.