

INSTALLATION & CALIBRATION MANUAL

LOADWISE MODEL 600

LOAD, LENGTH, ANGLE & RADIUS INDICATOR SYSTEM

Ref:600/16.12.04 Issue 2

600 *LOADWISE* SERIES 600 LOAD, LENGTH, ANGLE RADIUS SYSTEM

WARRANTY THERE ARE NO WARRANTIES, EXPRESS OR IMPLIED, MADE BY EITHER THE DISTRIBUTOR OR THE MANUFACTURER ON NEW LOADWISE EQUIPMENT, EXCEPT THE MANUFACTURER WARRANTY AGAINST DEFECT, MATERIAL AND WORKMANSHIP SET OUT BELOW.

The manufacturer warrants each new product made by the manufacturer to be free from defects in material and workmanship, its obligation and liability under this warranty being limited to replacing free of charge at its factory, any part proving defective under normal use and service within twelve (12) months from the date of delivery, providing the equipment is on record with the manufacturer as being installed by the distributor. If the machine is not on record as being installed by the distributor the manufacturer will consider the date of shipment from the factory. This warranty is in lieu of all other warranties, express or implied, and the obligation and liability of the manufacturer under this warranty shall not include transportation or other charges of consequential damages or delay resulting from the defect. Any operation beyond rated capacity or improper use or application of the product or the substitution upon it of parts not approved by the manufacturer shall void this warranty. This warranty covers only the products of Load Instrumentation Limited. The products of other manufacturers are covered only by such warranties as are made by their manufacturers.

THIS WARRANTY IS EXPRESSLY IN LIEU OF ANY WARRANTIES, EXPRESS OR IMPLIED, INCLUDING ANY IMPLIED WARRANTY OF MERCHANTABILITY OR FITNESS FOR AN INTENDED PURPOSE, AND OF ANY OTHER OBLIGATIONS OR LIABILITY ON THE PART OF THE MANUFACTURER, AND IT'S DISTRIBUTORS NEITHER ASSUMES NOR AUTHORIZES ANY OTHER PERSON TO ASSUME FOR IT ANY OTHER LIABILITY IN CONNECTION WITH SUCH EQUIPMENT.

This manual describes the operation and components of the *LOADWISE* Series 600. The *LOADWISE* Series 600 System is a modular system that is fitted to either telescopic or lattice boom cranes. It can be configured to display Load (one winch or two), Length, Angle, Radius and Anti Two Block. Additionally, operator-settable alarms are available for all displays. The system relies on the operator to set the display to the correct number of parts-of-line for each winch and to select the correct boom length/jib/jib offset.

WARNING:

THE SERIES 600 IS NOT AN AUTOMATIC LIMITER BUT SOLELY AN OPERATOR-PROGRAMMABLE DEVICE WITH VARIABLE LIMITS WHICH CAN BE MANUALLY SET ANYWHERE WITHIN THE CAPABILITIES OF THE SYSTEM.

THE OPERATOR IS TOTALLY RESPONSIBLE FOR SETTING THE VARIABLE LIMITS AND FOR OPERATING THE EQUIPMENT WITHIN THE PRESCRIBED LIMITS. THE SYSTEM RELIES ON THE OPERATOR SELECTING VARIOUS CONFIGURATIONS AND LIMITS WHERE NECESSARY.

The *LOADWISE* Series 600 Display Console is available in several different configurations. Your system may be slightly different from the sketches in this manual, depending on your crane, the display options you selected and the sensors you purchased. Also, portions of this manual may not apply to all crane applications.

Ref:00253/02/02

600

LOADWISE SERIES 600 LOAD, LENGTH, ANGLE RADIUS SYSTEM

Table of Contents

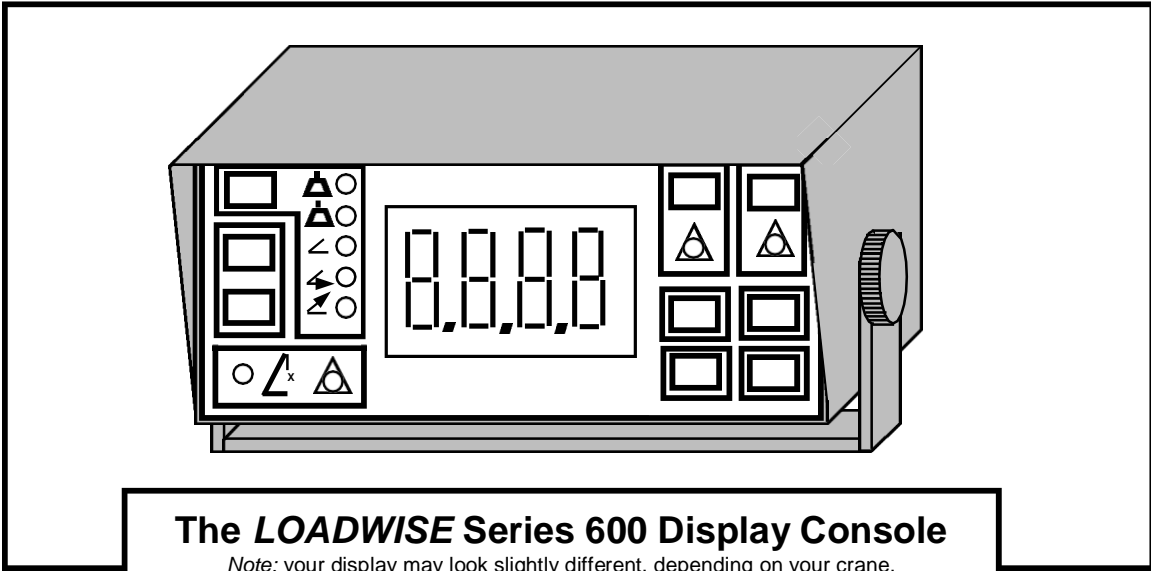

The *LOADWISE* Series 600 Display Console
Note: your display may look slightly different, depending on your crane, the display options you selected and the sensors you purchased.

TABLE OF CONTENTS		
INTRODUCTION	Page 4	INTRODUCTION
OPERATION	Page 8	OPERATION
INSTALLATION	Page 11	INSTALLATION
FAULT FINDING	Page 24	FAULT FINDING
CALIBRATION	Page 25	CALIBRATION

QUICK REFERENCE:	
RESET ALARM LIMITS	Page 10
ALARM DISPLAY MESSAGES	Page 24
FAULT DISPLAY MESSAGES	Page 24
ANALOG MODE	Page 40

600

LOADWISE SERIES 600 LOAD, LENGTH, ANGLE RADIUS SYSTEM

Introduction

The LOADWISE Series 600 Load, Length, Angle and Radius System is a modular crane system that, depending on your crane and the sensors you purchase, will display any one or all of: load (main winch only or main and aux winch), boom angle, boom length, radius, and anti two block. Additionally, the LOADWISE Series 600 offers output signals that can be connected to a “motion cut” or “function kick-out” system.

LOADWISE Series 600 Display/Crane Versions

601	Load only
602	Load + Angle
603	Load + Load
604	Load + Load + Angle
605	Angle + Length + Radius (Telescopic Cranes Only)
606	Angle + Radius (Lattice Boom Cranes Only)
607	Angle
608	Load + Angle + Length
609	Load + Angle (with Automatic Load Limit at preset Angle or Radius)
610	Load + Load + Angle + Length + Radius (Telescopic Cranes Only)
611	Load + Load + Angle + Radius (Lattice Boom Cranes Only)
OPTIONAL	Anti Two Block may be included in any of the above versions

INTRODUCTION

600

LOADWISE SERIES 600 LOAD, LENGTH, ANGLE RADIUS SYSTEM

Introduction

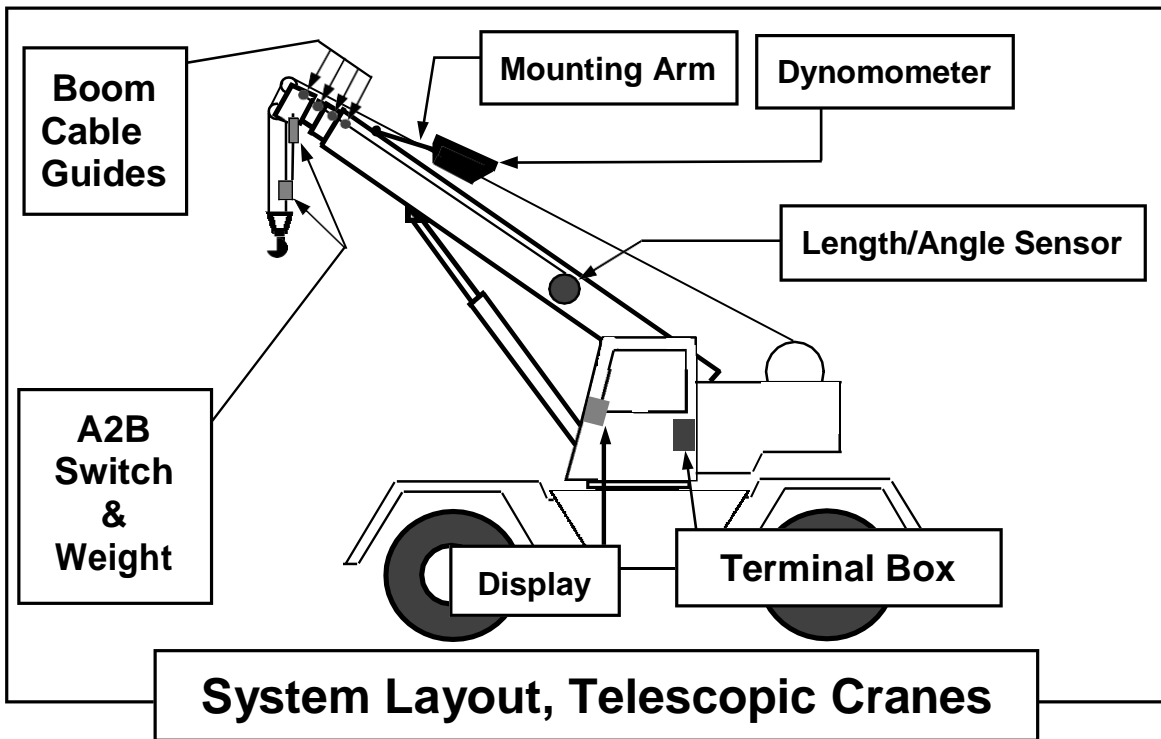

WHAT IT MEASURES: (ON TELESCOPIC CRANES)

LOAD - The load is usually sensed by a Dynamometer (running-line tensiometer) which has an electronic strain gauged load cell. Other types of load sensors include tension-link loadcells, shackle loadcells and wedge-socket pin loadcells.

ANGLE - A boom-mounted inclinometer unit which has an integral pendulum weight detects the boom angle referred to the horizon. On telescopic cranes, the angle sensor is inside the boom length drum.

BOOM LENGTH (Telescopic Cranes only) - The length of the boom is measured by a reeling drum which is mounted on the base section of the crane boom and which has a cable end attached to the boom head. This movement is converted to an analog signal by a potentiometer.

INTRODUCTION

600

LOADWISE SERIES 600 LOAD, LENGTH, ANGLE RADIUS SYSTEM

Introduction

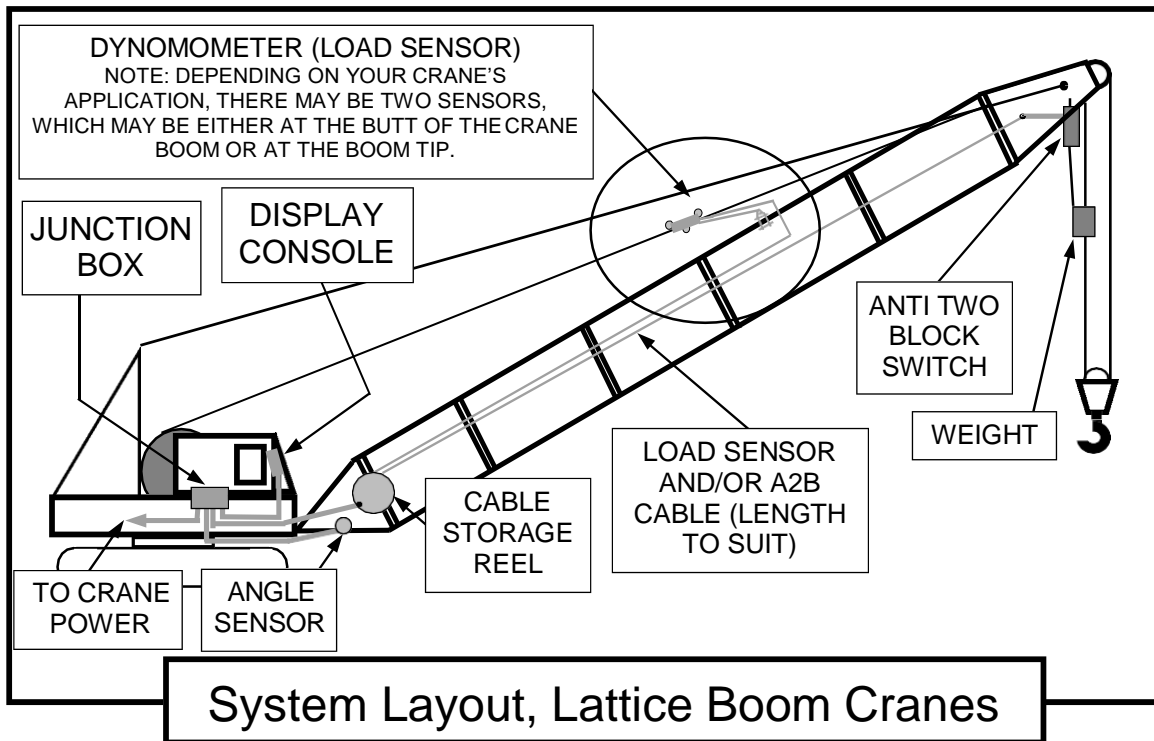

WHAT IT MEASURES: (ON LATTICE BOOM CRANES)

LOAD - The load is usually sensed by a Dynamometer (running-line tensiometer) which has an electronic strain gauged load cell. Other types of load sensors include tension-link loadcells, shackle loadcells and wedge-socket pin loadcells.

ANGLE - A boom-mounted inclinometer unit which has an integral pendulum weight detects the boom angle referred to the horizon. On telescopic cranes, the angle sensor is inside the boom length drum.

BOOM LENGTH (Lattice Boom Cranes) - the fixed boom length options are programmed into the unit for manual selection by the operator.

INTRODUCTIO

600

LOADWISE SERIES 600 LOAD, LENGTH, ANGLE RADIUS SYSTEM

Introduction

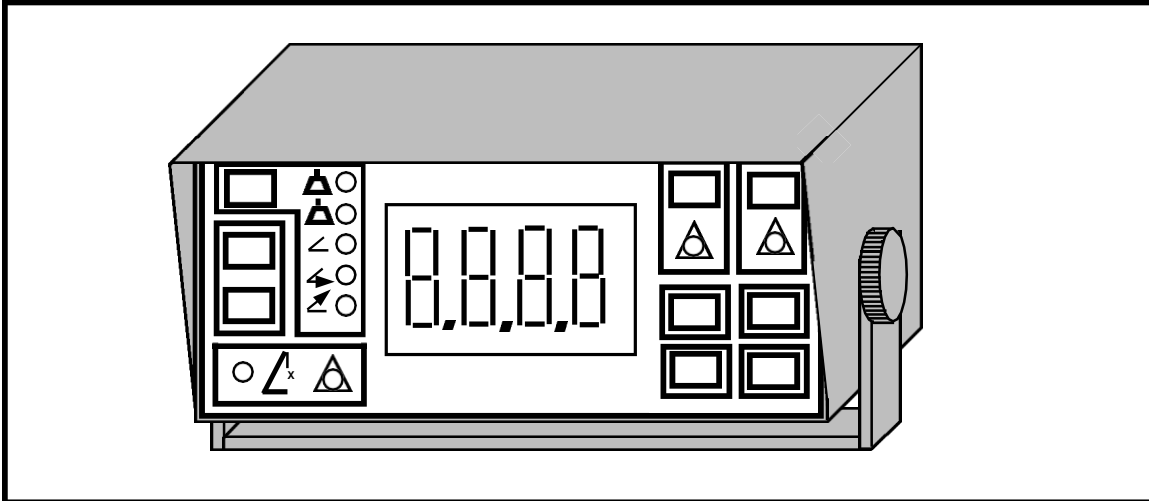

WHAT IT DOES:

LOAD - The strain gauge load output is sent to the computer which amplifies the signal to suit the number of parts of line reeved on the hook block. This is then displayed in digital form and represents the total load including the weight of the rope, hook block and any other slings, etc. This load is automatically compared to the maximum line pull; a warning lamp and buzzer will actuate if exceeded. There is also an operator-adjustable max load limit which, when exceeded, will actuate a warning lamp and buzzer.

RADIUS - The computer looks at the boom angle, boom length, the length of the jib and other data, and computes the operating radius which is displayed when the SELECT lamp is on the radius. An operator-adjustable maximum radius limit is available and will actuate a warning lamp and buzzer when exceeded.

BOOM LENGTH - The boom length is displayed when the length lamp is selected. An operator-adjustable maximum boom length limit is available (on telescopic booms only) and will actuate a warning lamp and buzzer when exceeded.

ANGLE - The boom angle is displayed when the angle lamp is exceeded. Operator-adjustable high and low boom angle limits are available and will actuate a warning lamp and buzzer when exceeded.

NOTE: ALL PRESET LIMITS WILL ALARM IRRESPECTIVE OF THE DISPLAY MODE

INTRODUCTION

600

LOADWISE SERIES 600 LOAD, LENGTH, ANGLE RADIUS SYSTEM

Operation

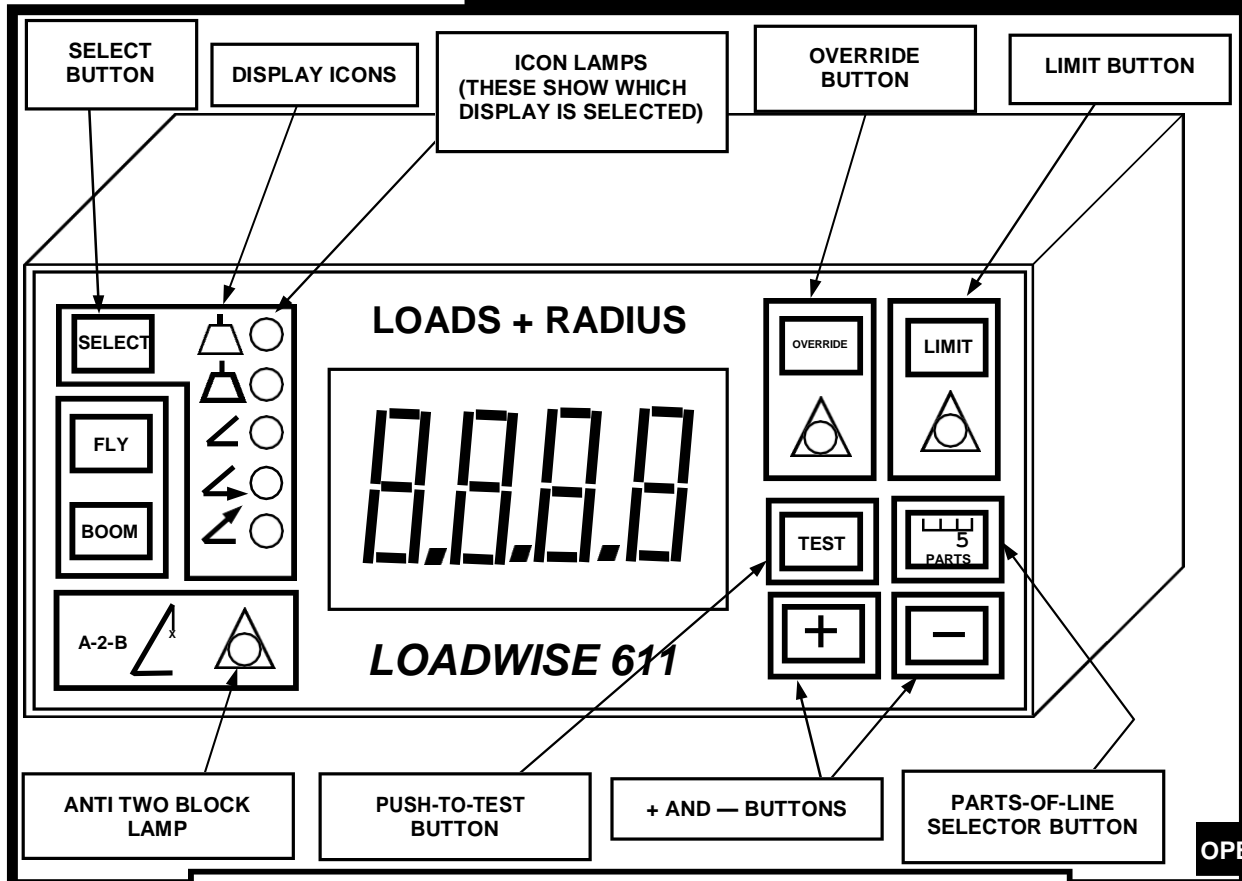

The LOADWISE Model 611 Display Panel

Operation - immediately on switch-on the indicator conducts a self-check routine which will activate the lamps and alarms while also displaying the serial number of the unit.

Select - depending on the model there are options of display which include the following:

- 1) Load (main winch) (**LOAD IS DISPLAYED IN 1,000 LB INCREMENTS.**)
- 2) Load (aux winch)
- 3) Boom Angle
- 4) Boom Length
- 5) Radius

Where applicable these are selected for display by pressing the SELECT button and the lamp will show next to the icon for the mode selected.

There are various buttons on the console, which, depending on the model, function as follows on the next page when in normal mode. (For a description of the button functions when in CALIBRATION mode, see the Calibration section.)

600

LOADWISE SERIES 600 LOAD, LENGTH, ANGLE RADIUS SYSTEM

Operation

Display Button Functions

- **TEST** - when pressed, the test button will sound the buzzer and activate the “motion-cut” system, if fitted.
- **OVERRIDE** - when pressed, will override the limit/A2B alarm and will illuminate the RED override lamp, stop the buzzer and will disengage the “motion-cut” system, if fitted. The override may be cancelled by a second press of the button. Otherwise it will cancel automatically when the alarm state has been removed.
- **LIMIT** - when pressed will show the limit value for the function that is selected.
- **A-2-B** - (Anti Two Block) - the Anti Two Block (or overhoist limit) display lamp is operated by a boom head switch/chain & weight. If this is operational the A2B lamp and buzzer will sound when the hoist limit is reached. If not required, it will be linked-out inside the Junction Box.
- **UNITS** - (not on Models 610/611) - the display can be selected to read out in metric or imperial units, except angle which is always in degrees. The imperial is converted from the metric value so exact values may not be displayed.
- **TARE** - (not on Models 610/611) - at the push of a button the load is subtracted from itself (to give zero). Any additional load will then be shown on the display. This function is primarily used to remove the weight of the block and tackle prior to weighing the load, and can be done separately for each load input. Any “tared” display only affects the displayed load as the alarms are calculated on the GROSS LOAD limits.
- **PARTS OF LINE** - used to select parts of line for which the crane is reeved. (Note: for units with two winches, the **PARTS** may be set at different values for each winch.)
To select parts of line:
 - 1) Select display mode that is to be used (main winch or aux winch).
 - 2) Press the button marked **PARTS** - while the button is being held down, it will display the present parts of line setting (ignore the decimal point).
 - 3) While holding down the **PARTS** button, press the “+” or the “-” buttons as applicable.
- **SELECT** - used to select the mode to be displayed. Press the **SELECT** button until the lamp illuminates next to the icon for the mode you want to be displayed..

TO SELECT BOOM LENGTH (Models 606/611 on Lattice Boom Cranes) - use the **BOOM** button to display the boom length. To alter the boom length, press the **BOOM** button and while holding it down, press the “+” or the “-” button to select the other boom length options available.

TO SELECT FLY JIBS/JIBS (Models 605/606/610/611) - press the **FLY** button; while this button is being held down, the display will alternate between jib angle then length. (For example, a 5.0 then 35 is a 35 ft. jib at a 5 ° offset.) While the **FLY** button is pressed, other preset options of jib length and angle may be selected by using the “+” or “-” buttons. NOTE: when there is no jib in use the **FLY** selection should be set to “0”, “0”.

OPERATION

600

LOADWISE SERIES 600 LOAD, LENGTH, ANGLE RADIUS SYSTEM

Operation

LIMIT SETTINGS (all models)

- 1) Use the **SELECT** button to obtain the function.
- 2) Hold the **LIMIT** button down to view the limit set.
- 3) To change by 0.1, press the "+" or the "-" button and release.
- 4) To change by 1.0, press the "+" or the "-" button continuously for 5 seconds or more while keeping the **LIMIT** button pressed.
- 5) To change by 10.0, press the "+" or the "-" button continuously for 10 seconds or more while keeping the **LIMIT** button pressed.

TO SET THE LOAD LIMITS (Models 601/602/603/604/608/610/611)

- 1) Select the first or second load (where applicable) using the **SELECT** button. Each load can be set with its own load limit.
- 2) Press the **LIMIT** button-the display will show the limit set while the button is held in. To change this limit, keep the button pressed and press the "+" or the "-" buttons until the required limit is displayed. The load limit will remain until adjusted again by the above method. Any load lifted in excess of the load limit or hoist rope limit will light the RED lamp and sound the buzzer.

TO SET THE LOAD LIMITS (Model 609) - this is the same as above except there are two load limits that can be set. These are actuated by boom angle: above the high angle limit one load limit can be set; below the low boom angle limit another load limit can be set.

TO SET THE ANGLE LIMITS (Models 602/604/605/606/607/608/609/610/611)

- 1) Select the angle display using the **SELECT** button and with the boom above 45°, press the **LIMIT** button to display the existing high angle limit. This may be changed to any angle between 0° and 89° by pushing the "+" or the "-" buttons while the **LIMIT** button is held down.
- 2) The low angle limit may be adjusted by the same method as above but the boom must be below 45° in order to display or change the low limit.

REMINDER

Put boom above 45° to display or reset the high angle limit.
Put boom below 45° to display or reset the low angle limit.

TO SET RADIUS LIMIT (Models 605/606/610/611)



Use the **SELECT** button to light the lamp next to the icon appearing at the left. Pressing the **LIMIT** button will display the maximum radius limit. This may be altered by pressing the "+" or the "-" buttons as required.

TO SET MAIN BOOM LENGTH LIMIT (Models 605/608/610)

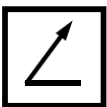

With the **SELECT** button, light the lamp next to the icon appearing at the left. Pressing the **LIMIT** button will display the maximum boom length limit. This may be altered by pressing the "+" or the "-" buttons as required.

RESET ALARM LIMITS

To clear the alarms when in a normal operating mode (i.e. NOT in CAL mode).

To clear the alarms, press four buttons simultaneously:

"+", "-", "OVERRIDE", and "LIMIT"

Note: the "LIMIT" button must be pressed last.

OPERATION

600

LOADWISE SERIES 600 LOAD, LENGTH, ANGLE RADIUS SYSTEM

Installation

DYNOMOMETER - The Dynamometer is usually a three-roller device with the center roller running on a strain gauged shaft. It is supplied complete for installation on the crane. Larger cranes with hoist ropes in excess of 7/8" will require a large 3-roller or 5-roller unit.

This assembly is positioned such that the hoist rope passes through the Dynamometer, and is typically on a mounting arm which allows the Dynamometer to follow the movements of the rope path. On lattice boom cranes, the Dynamometer may be attached near the boom tip, either in a rigid position or on a "swing arm". The cable from the Dynamometer to the junction box must have sufficient protection from accidental damage and wear. Care should be taken when routing this loadcell cable to allow sufficient loop for the movement of the Dynamometer's "swing arm" and at the boom hinge.

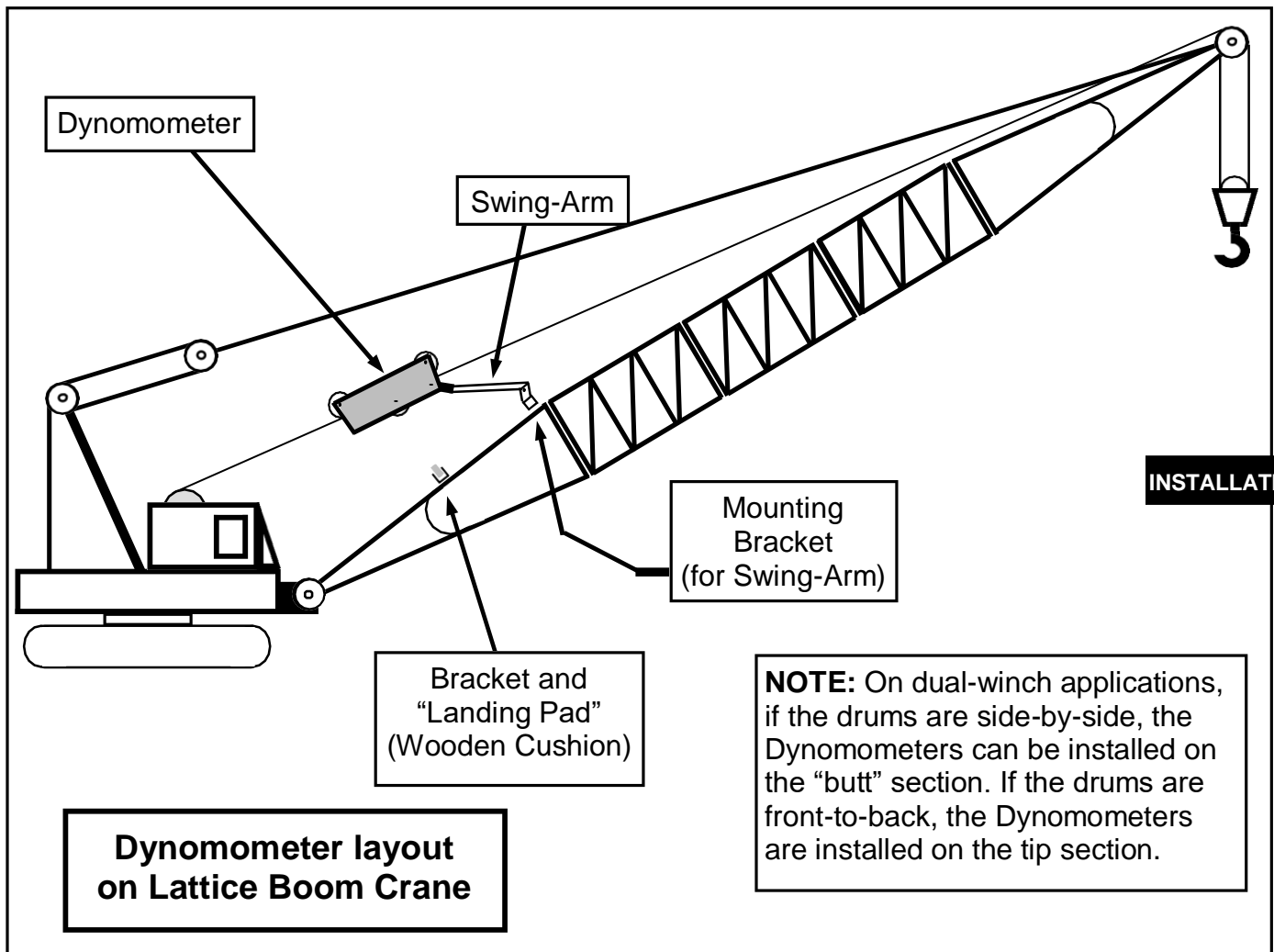

600

LOADWISE SERIES 600 LOAD, LENGTH, ANGLE RADIUS SYSTEM

Installation

DYNOMOMETER - The Dynamometer is usually a three-roller device with the center roller running on a strain gauged shaft. It is supplied complete for installation on the crane. Larger cranes with hoist ropes in excess of 7/8" will require a large 3-roller or 5-roller unit.

This assembly is positioned such that the hoist rope passes through the Dynamometer, and is typically on a mounting arm which allows the Dynamometer to follow the movements of the rope path. On hydraulic cranes, the Dynamometer may be attached near the tip of the butt section, either in a rigid position or on a "swing arm". The cable from the Dynamometer to the junction box must have sufficient protection from accidental damage and wear. Care should be taken when routing this loadcell cable to allow sufficient loop for the movement of the Dynamometer's "swing arm" and at the boom hinge.

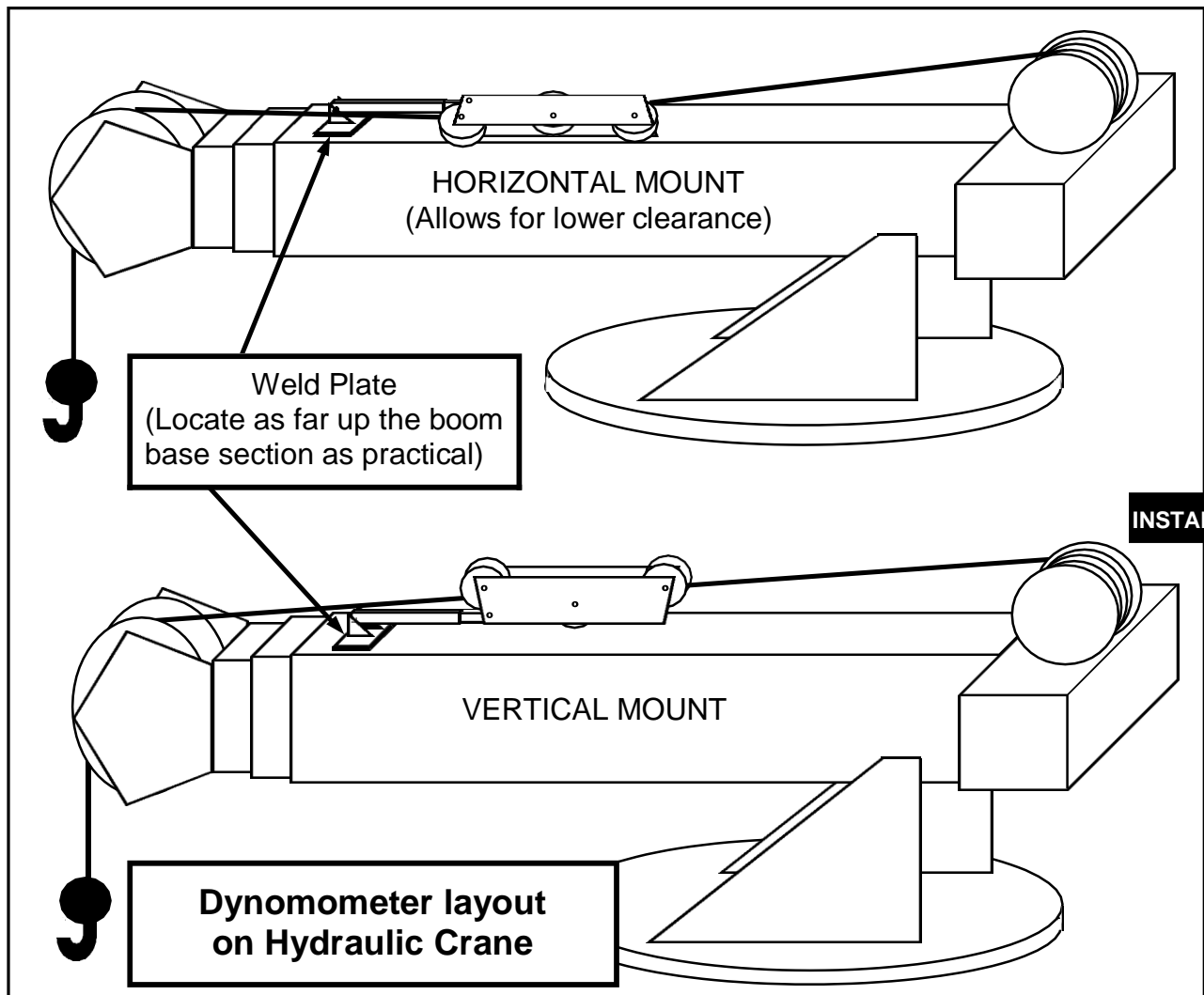

600

LOADWISE SERIES 600 LOAD, LENGTH, ANGLE RADIUS SYSTEM

Installation

LENGTH/ANGLE SENSOR ON TELESCOPIC CRANES - The boom length/angle sensor is fitted on the base of the boom, (on the driver's cab side of the crane boom,) with the wide bracket parallel to the boom center line and with the cable guides attached to each section and the end attachment on the boom tip. (See the drawings on pages 14 & 15.)

Standard fitting is on the left side of the boom, with the extension wire paying out from the top of the drum. When installing the length/angle sensor on the right hand side of the boom, the extension cable will pay off from the bottom of the drum and the pendulum limit pin must be changed to the alternative position (see sketch below).

Installation of Length/Angle Sensor on Telescopic Crane

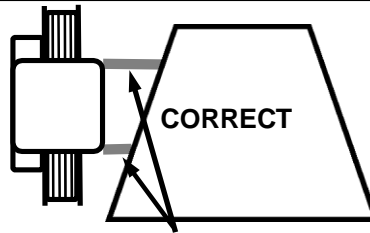
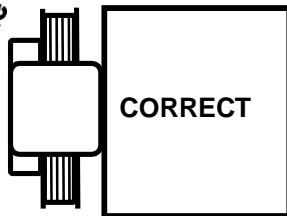

Use stand-offs, if necessary, to ensure the Cable Reeling Drum is installed

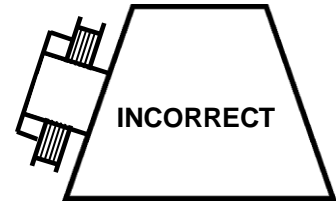

CUT-AWAY VIEW OF TELESCOPIC CRANE BOOM

Inside of Angle Sensor

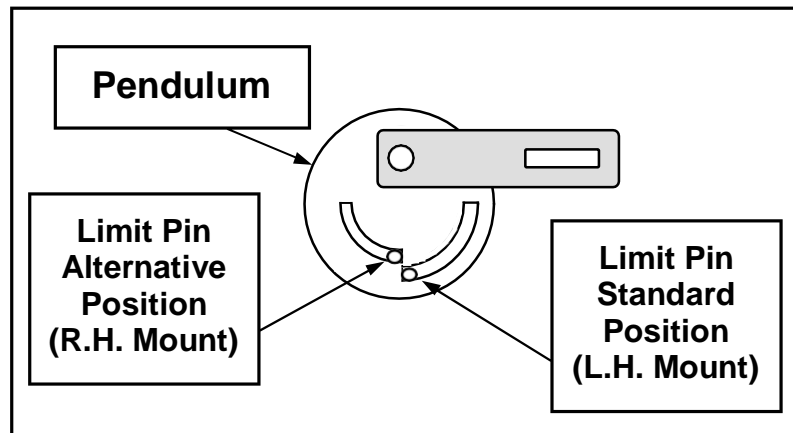

INSTALLATION

This sketch shows the inside of the Angle Sensor, which is located inside the Length/Angle Sensor on Hydraulic cranes. The Limit Pin is a hex-socket cap screw, which is moved from the standard position to the alternative position when the Angle Sensor is mounted on the right-side of the crane boom.

600

LOADWISE SERIES 600 LOAD, LENGTH, ANGLE RADIUS SYSTEM

Installation

Installation of the Cable Reeling Drum

1

Install the Cable Reeling Drum on the base of the crane boom, with the wide bracket parallel to the boom center line. After mounting the Cable Reeling Drum, open the cover and disengage the gear attached to the boom length sensing potentiometer.

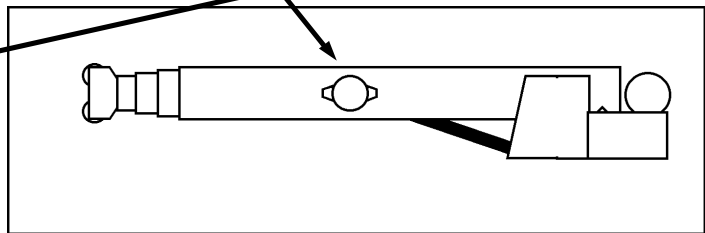

When shipped from the factory, the Cable Reeling Drum is pre-set for installation on the left-hand side of the crane boom. If installing on the right-hand side of the crane boom, follow the directions on page 13 to change the Angle Sensor's swing to accommodate this.

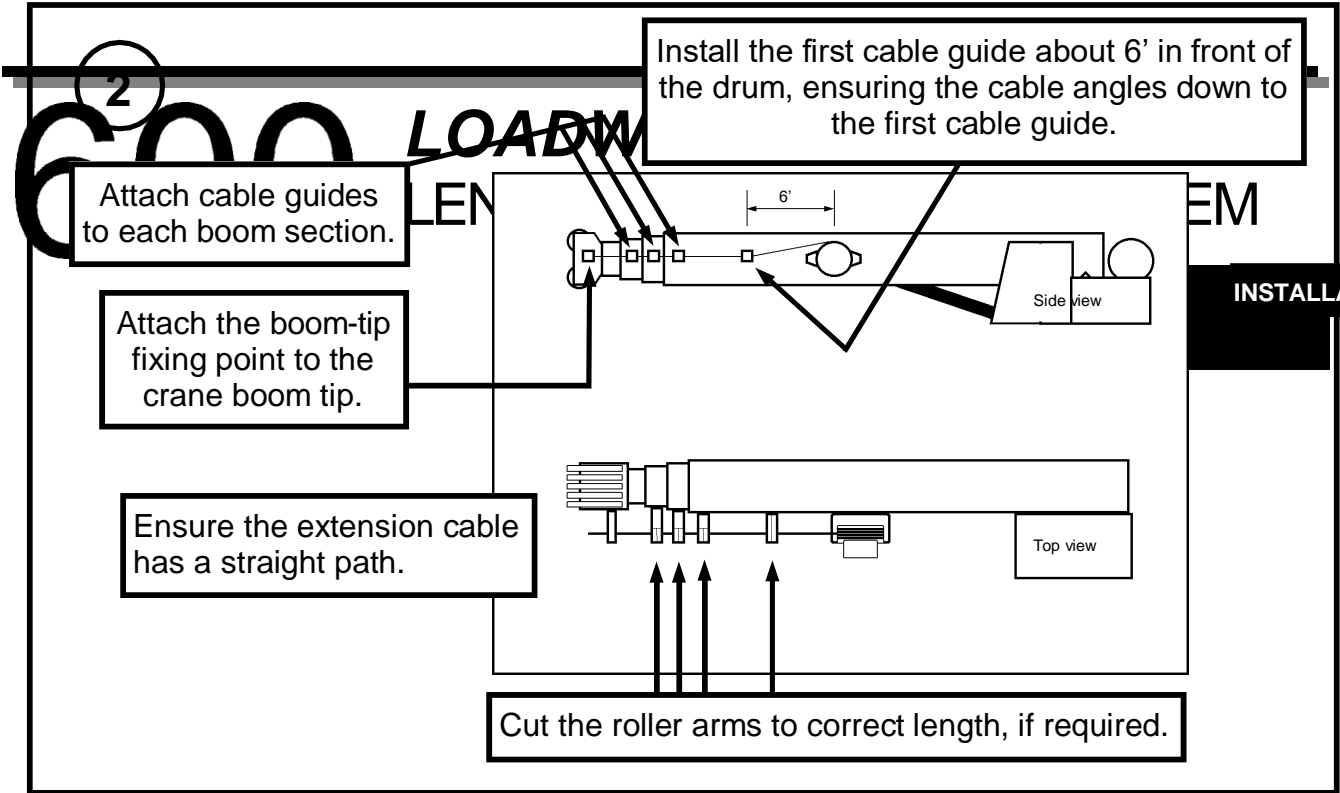

600

LOADWISE SERIES 600 LOAD, LENGTH, ANGLE RADIUS SYSTEM

Installation

3

With the boom fully retracted, measure back 19' from the boom-tip fixing point, and mark this position.

Boom-tip fixing point

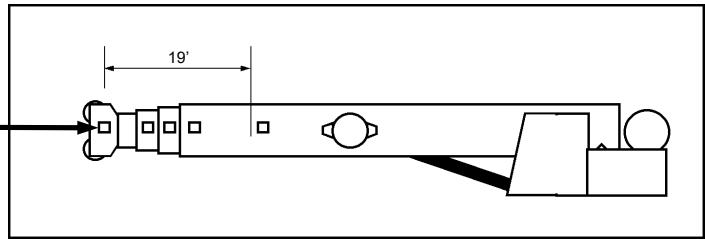

4

Remove extension cable
(without tension) to this position.

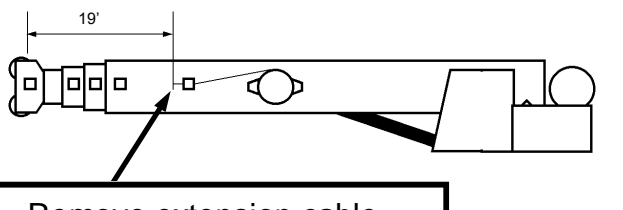

With the cable still on the spool, rotate the spool BACKWARDS until it “clicks” twice, and allow the spool to find its natural (untensioned) starting point. Without turning the reeling drum’s spool, remove enough cable from the spool to reach the (19’) marked position.

5A Feed the cable through the cable guides and to the boom-tip fixing point, allowing the reeling drum to tension, and pull on the cable until it is about 2 feet beyond the boom-tip fixing point.

INSTALLATION

5B Attach the extension cable to the boom-tip fixing point and connect it to the A2B Switch, using the female 2-pin connector. Connect the inner steel wire to the “L” contact on the socket, and the braided shield to the “N” contact on the socket.

5C With the boom fully retracted, turn the gear on the length pot COUNTER-CLOCKWISE until it hits its interal stop. Turn the gear CLOCKWISE one turn and engage the gear to its pinion gear. Proceed to the length calibration as per the system’s manual.

600

LOADWISE SERIES 600 LOAD, LENGTH, ANGLE RADIUS SYSTEM

Installation

ANTI TWO BLOCK SWITCH/WEIGHT & CHAIN - The Anti Two Block Switch Unit is attached, using the bracket supplied, to the boom head near the dead-end attachment, so the weight can be placed around the dead-end line. To open the weight, looking down on the weight, one side must be pulled up and the other side pushed down to release the lock pin. On Telescopic cranes, the boom length (extension) cable and drum carry the A2B signal to the Junction Box. On Lattice Boom Cranes, a separate cable is used. If Anti Two Block is not supplied, the wiring inside the terminal box is linked-out.

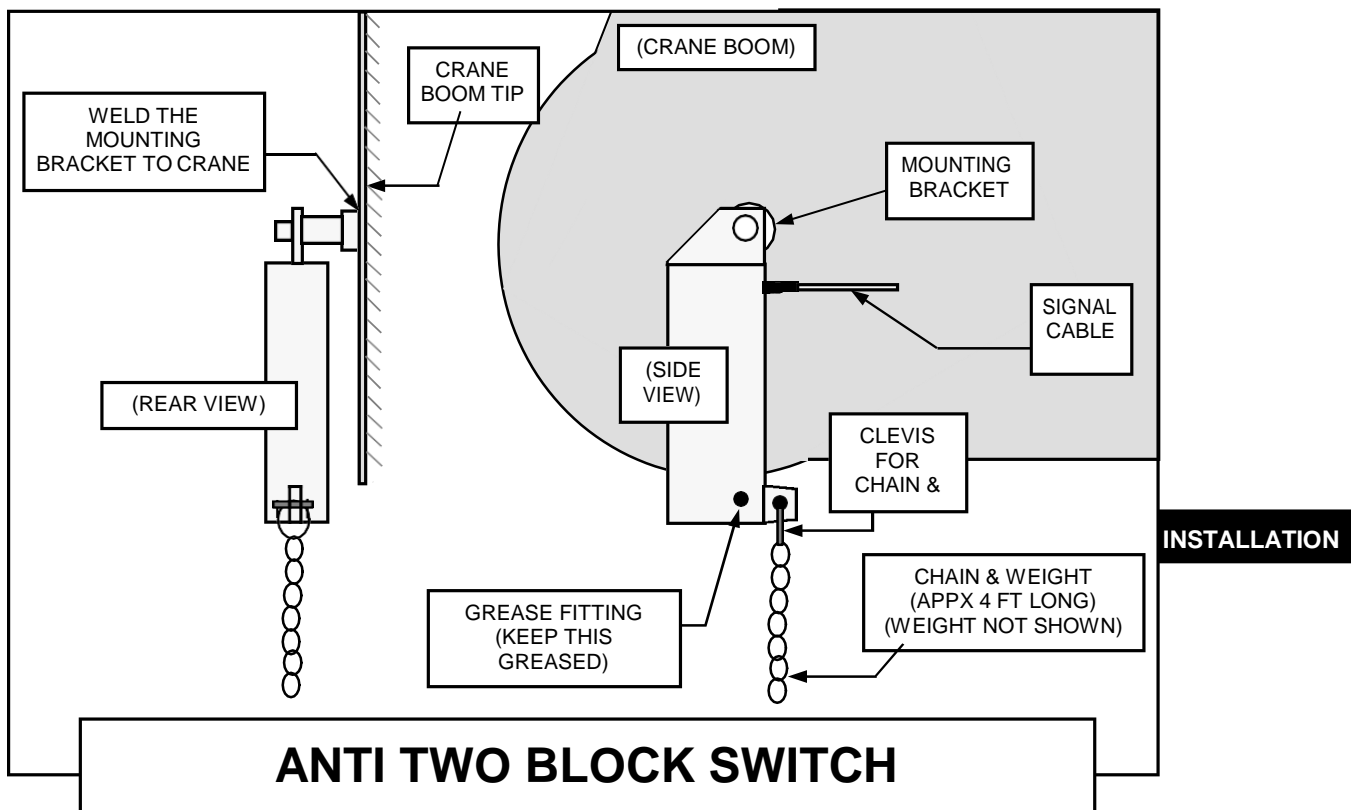

600

LOADWISE SERIES 600 LOAD, LENGTH, ANGLE RADIUS SYSTEM

Installation

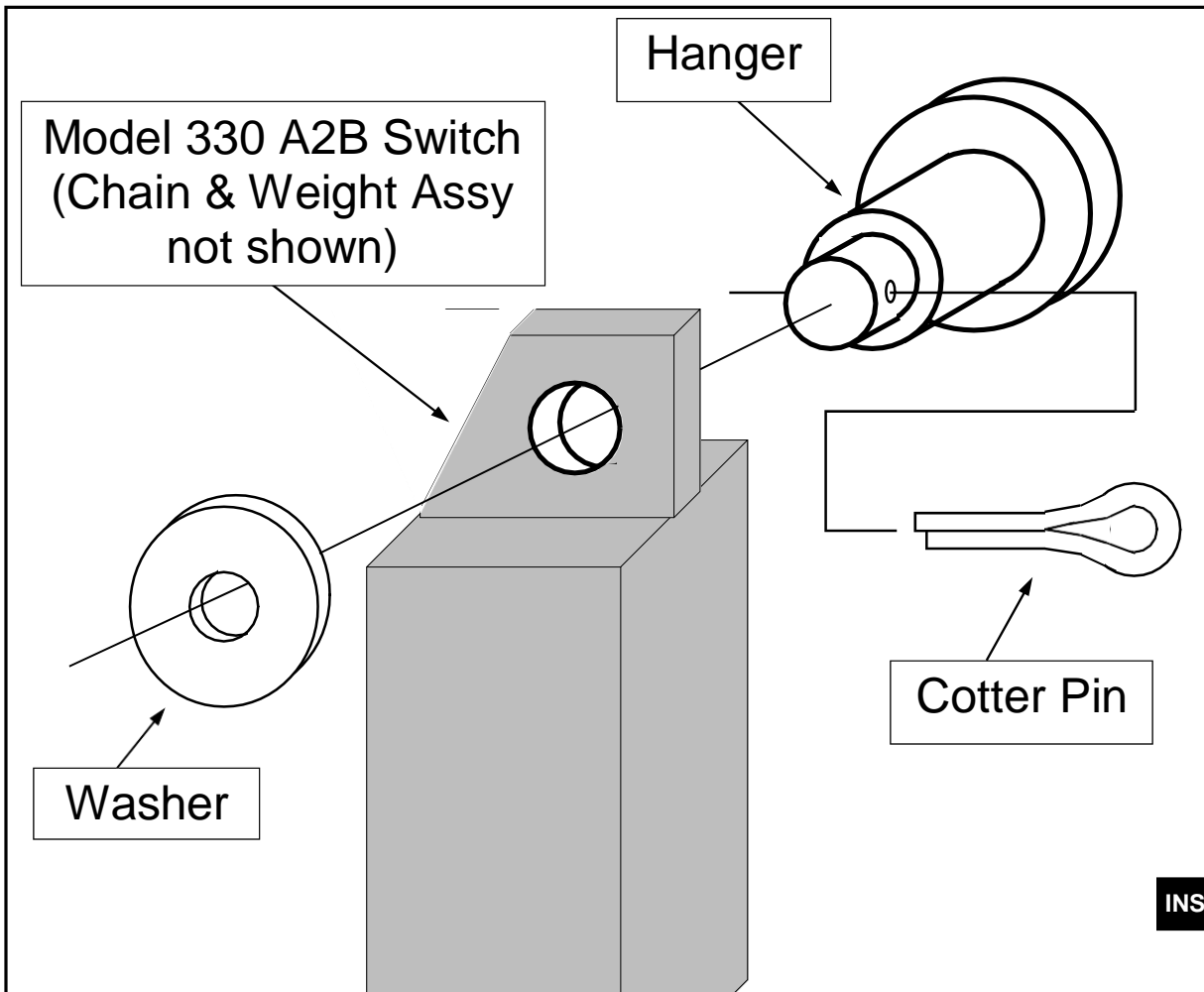

INSTALLATION

Installation of Hanger:

- A) Weld hanger to side of boom
or
- B) If access to inside of boom is available, drill a $\frac{7}{16}$ " hole and bolt hanger to boom through the hole

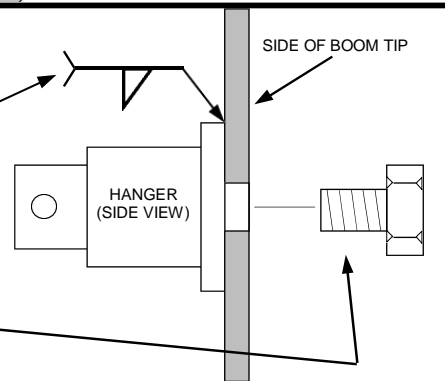

600

LOADWISE SERIES 600 LOAD, LENGTH, ANGLE RADIUS SYSTEM

Installation

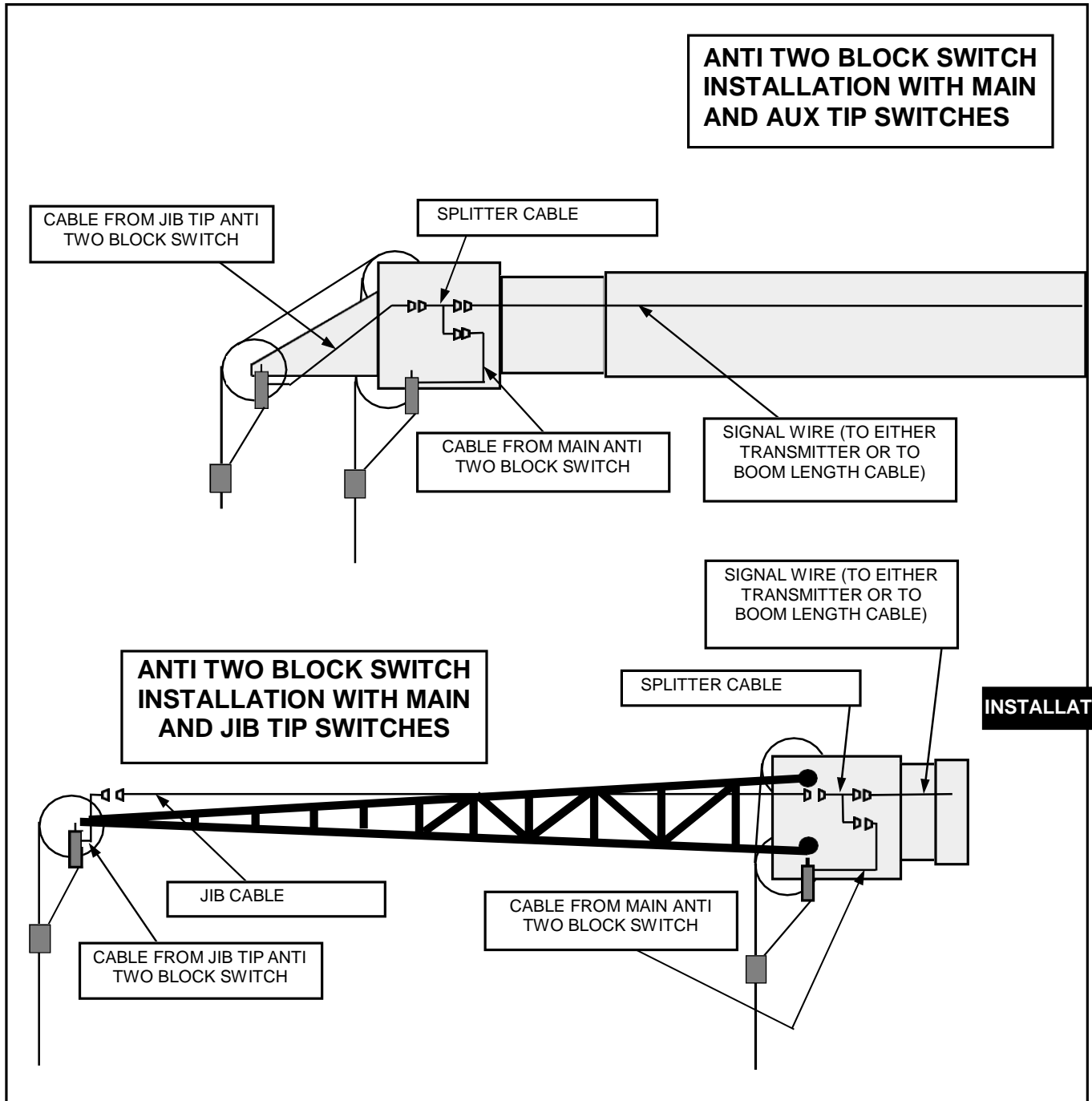

600

LOADWISE SERIES 600 LOAD, LENGTH, ANGLE RADIUS SYSTEM

Installation

The valve(s) are located in the lines running to those fluid-power functions that cause the A2B condition to occur. In a non-A2B condition, the valves are powered (opened) by the indicator's relay; in an A2B condition, power is removed from the valves (causing them to close), thereby blocking fluid from reaching the function and causing the function to stop. Excess fluid is vented to tank over the pressure relief valve.

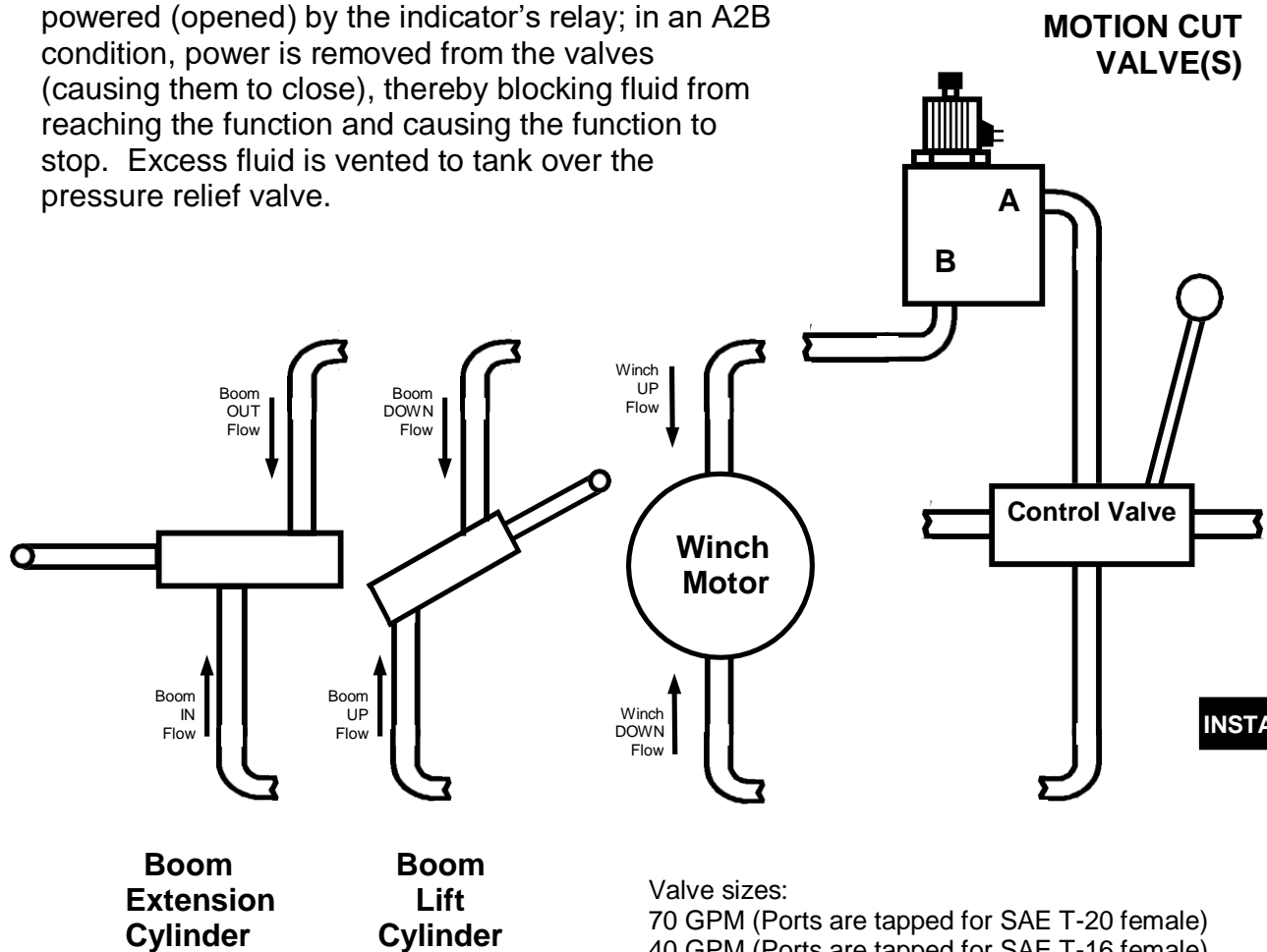

Note: on a two-winch crane, two valves are required for the winch lines. On a crane with independently-actuated boom extension cylinders, additional valves are required.

Typically, 70 GPM valves are used on the winch line, and 40 GPM valves are used on the boom extension line and on the boom down line.

INSTALLING MOTION-CUT VALVES

600

LOADWISE SERIES 600 LOAD, LENGTH, ANGLE RADIUS SYSTEM

Installation

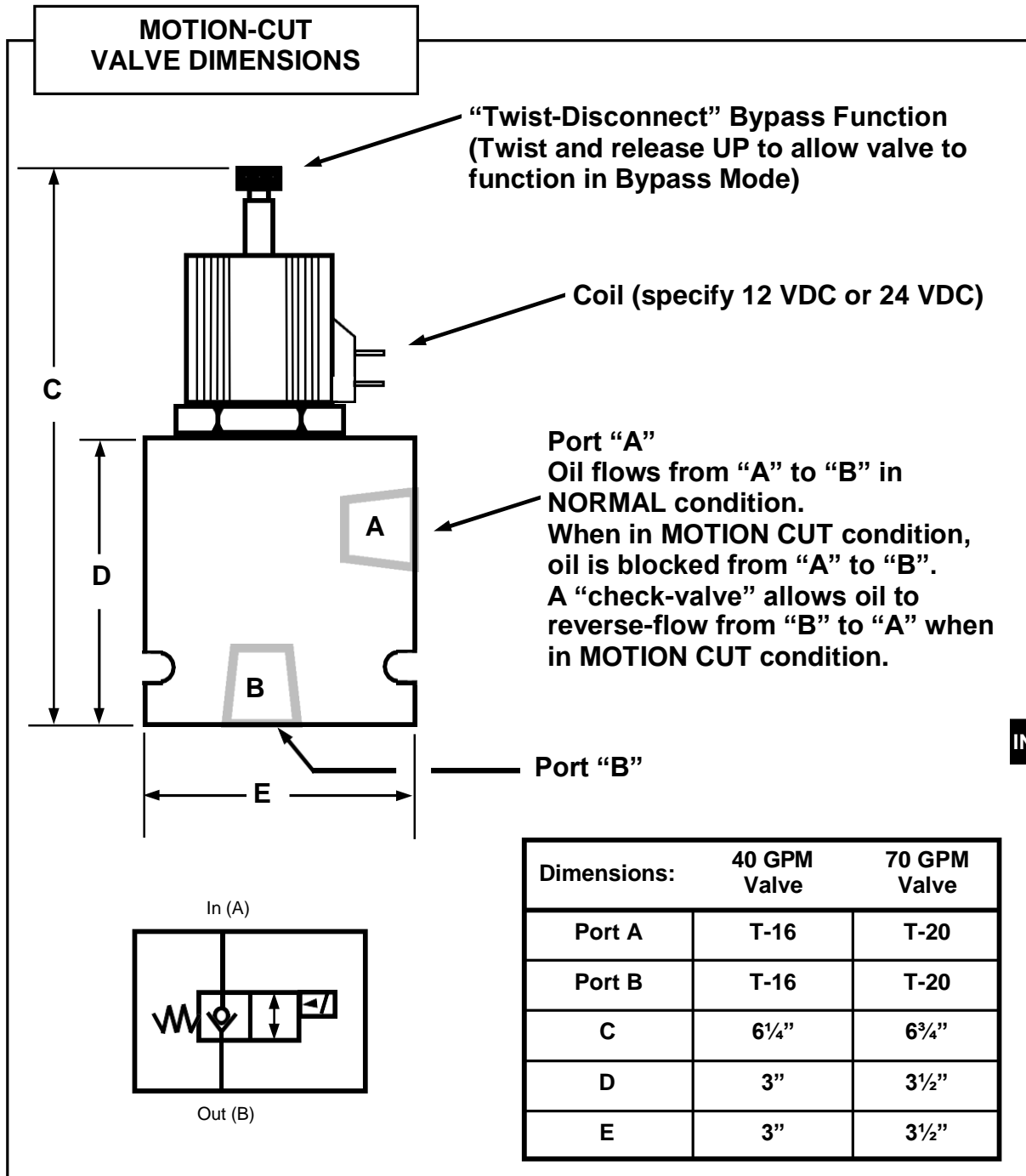

INSTALLATION

600

LOADWISE SERIES 600 LOAD, LENGTH, ANGLE RADIUS SYSTEM

Installation

DISPLAY CONSOLE - The Display Console is positioned in the operator's cab within easy sight and reach of the operator. It has a cable assembly which is plugged directly into the Junction Box. Several versions are available, depending on the type of crane and the display functions.

JUNCTION BOX - The Junction Box contains the protection circuits, terminal blocks, cables from the sensors, and an externally accessed one-amp fuse to protect the system. This is normally positioned inside the operators cab in any convenient location. See sketch below for mounting dimensions. Plugs & sockets are not standard supply.

600

LOADWISE SERIES 600 LOAD, LENGTH, ANGLE RADIUS SYSTEM

Installation

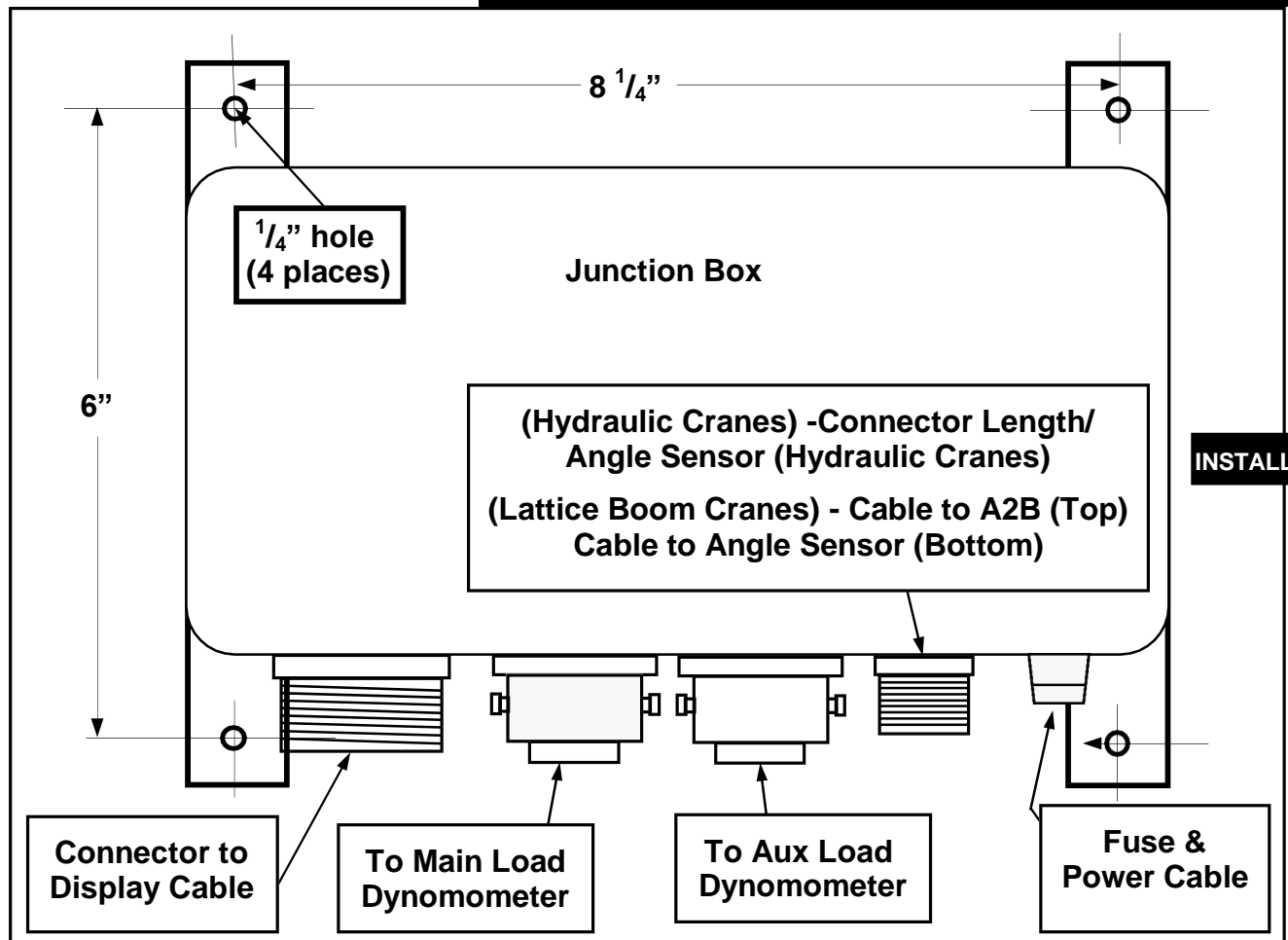

WIRING FOR NEW "600" UNIT

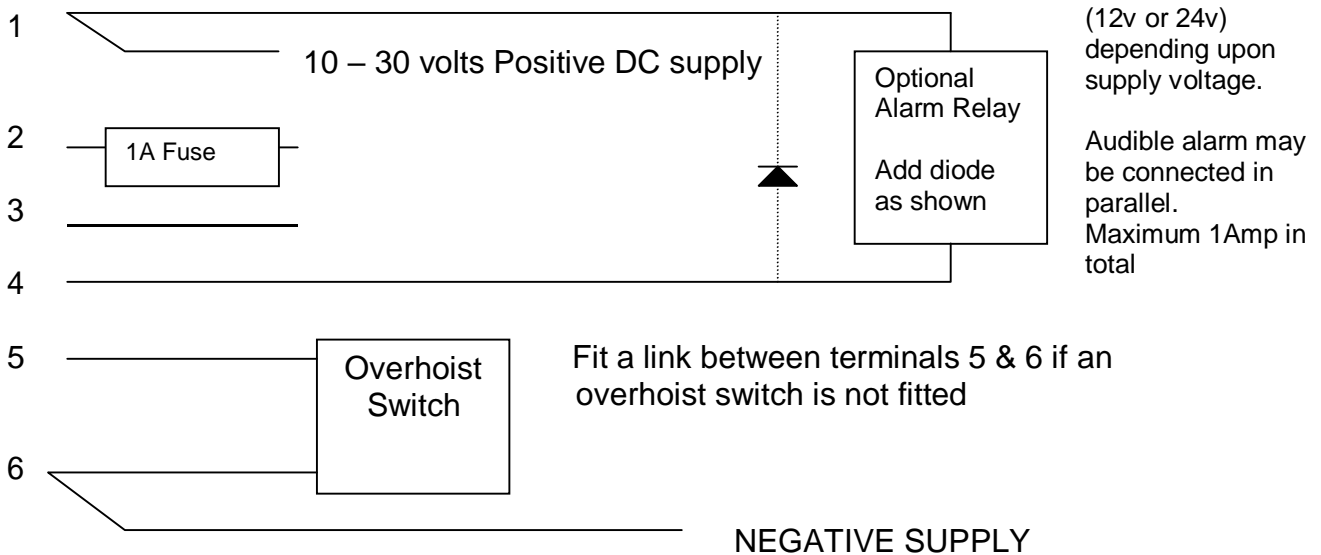

7	Red	}	Boom Length Pot			
8	Blue					
9	Green					
10	Yellow	}	Angle pot OR	Electronic Yellow to Pin 1	}	Angle Sensor PCB
11	White			White to Pin 2		
12	Black			Black to Pin 3		

*See note below

T/BLOCK 2

1	Red	}	Loadcell 1 (Main)
2	Yellow		
3	Blue		
4	Green		

T/BLOCK 3

1	Red	}	Loadcell 2 (Aux)
2	Yellow		
3	Blue		
4	Green		

* Note When connecting the angle sensor appropriate links must be made on the printed circuit board depending on which type of angle sensor is used. This would normally have been done in manufacture if ordered as a kit.

- 1) Potentiometer (Pendulum type) Pin 1 → Pin 3, Pin 6 → Pin 7, Pin 4 → Pin 5
- 2) Electronic Type (Solid State) Pin 1 → Pin 2, Pin 6 → Pin 8

600

LOADWISE SERIES 600 LOAD, LENGTH, ANGLE RADIUS SYSTEM

Fault Finding

The LOADWISE 600 has a microprocessor as the “nerve center” which monitors all the inputs and the alarm levels constantly. Should a fault occur in any of the input circuits the display will immediately flash “F” on the last digit regardless of which sensor input is being displayed.

To identify which sensor input circuit is at fault, consult the chart located below. Having located the faulty sensor input, next check the wiring from the sensor to the Junction Box. If necessary, follow the wiring drawing found on pages 22 or 23.

The Analog mode may be used to monitor each input range. For further information, see page 40 in the Calibration section.

FAULT DISPLAY MESSAGES	
DISPLAY READING	SENSOR FAULT
Ld1F	Main (1st) Winch
Ld2F	Aux (2nd) Winch
An F	Angle Sensor
LEnF	Length Sensor

ALARM DISPLAY MESSAGES	
DISPLAY READING	THE SYSTEM IS IN ALARM DUE TO:
Ld1P	Main (1st) Winch Max Line Pull
Ld2P	Aux (2nd) Winch Max Line Pull
Ld1	Main (1st) Winch Max Load Limit
Ld2	Aux (2nd) Winch Max Load Limit
An H	High Boom Angle Limit
An L	Low Boom Angle Limit
rAD	Max Radius Limit
LEn	Max Boom Length Limit (Telescopic Cranes only)
LEn	Preset Boom Length is Zero (Lattice Boom Cranes only)

FAULT FINDING

600

LOADWISE SERIES 600 LOAD, LENGTH, ANGLE RADIUS SYSTEM

Calibration

The LOADWISE 600 Series is calibrated using its display panel. Calibration consists of selecting the various display **MODES**, (main load, aux load, length, angle, radius, etc.,) and then entering information at four **CAL LEVELS**. While the process can seem to be intimidating at first, it is no more difficult than programming a VCR to record a TV program.

To enter the calibration mode:

- A) Turn off the power to the unit.
- B) Hold down the **OVERRIDE** button and the **LIMIT** button at the same time.
- C) Turn on the power while holding down both the **OVERRIDE** and the **LIMIT** buttons.
- D) Once the display reads out "CAL", release both the **OVERRIDE** button and the **LIMIT** button. The first decimal point will flash to indicate that the calibration mode has been selected. If any other decimal point is flashing, or if the first decimal point is not flashing, go back to step A above.
- E) To exit the CAL mode, press **OVERRIDE** and **LIMIT** at the same time.

In the calibration mode:

- A) Identify the display **MODE** to be calibrated (see the chart for your crane on page 27 or 28).
- B) Make the display read the **MODE** to be calibrated by pressing the **SELECT** button until the lamp next to the icon for the display **MODE** is lit.
- C) Go to the correct **CAL LEVEL** for the display **MODE** by pressing the **LIMIT** button and (while holding down the **LIMIT** button) pressing "+" or "-" until the decimal points flash for the **CAL LEVEL** selected.
- D) Enter the data as necessary.

To exit the calibration mode:

- A) Press **OVERRIDE** and **LIMIT** at the same time.

NOTE: YOU MUST EXIT THE CALIBRATION MODE AS ABOVE (by pressing OVERRIDE and LIMIT) TO SAVE THE CALIBRATION TO THE COMPUTER'S MEMORY. IF THE SYSTEM'S POWER IS SHUT OFF BEFORE PRESSING OVERRIDE AND LIMIT, THE SYSTEM WILL REVERT TO THE PRIOR CALIBRATION.

A sketch showing the 600 display panel on page 26 shows how to identify the **CAL LEVELS**. See Page 27 or Page 28 for the chart showing the display **MODES** and **CAL LEVELS** for your specific crane.

CALIBRATION

600

LOADWISE SERIES 600 LOAD, LENGTH, ANGLE RADIUS SYSTEM

Calibration

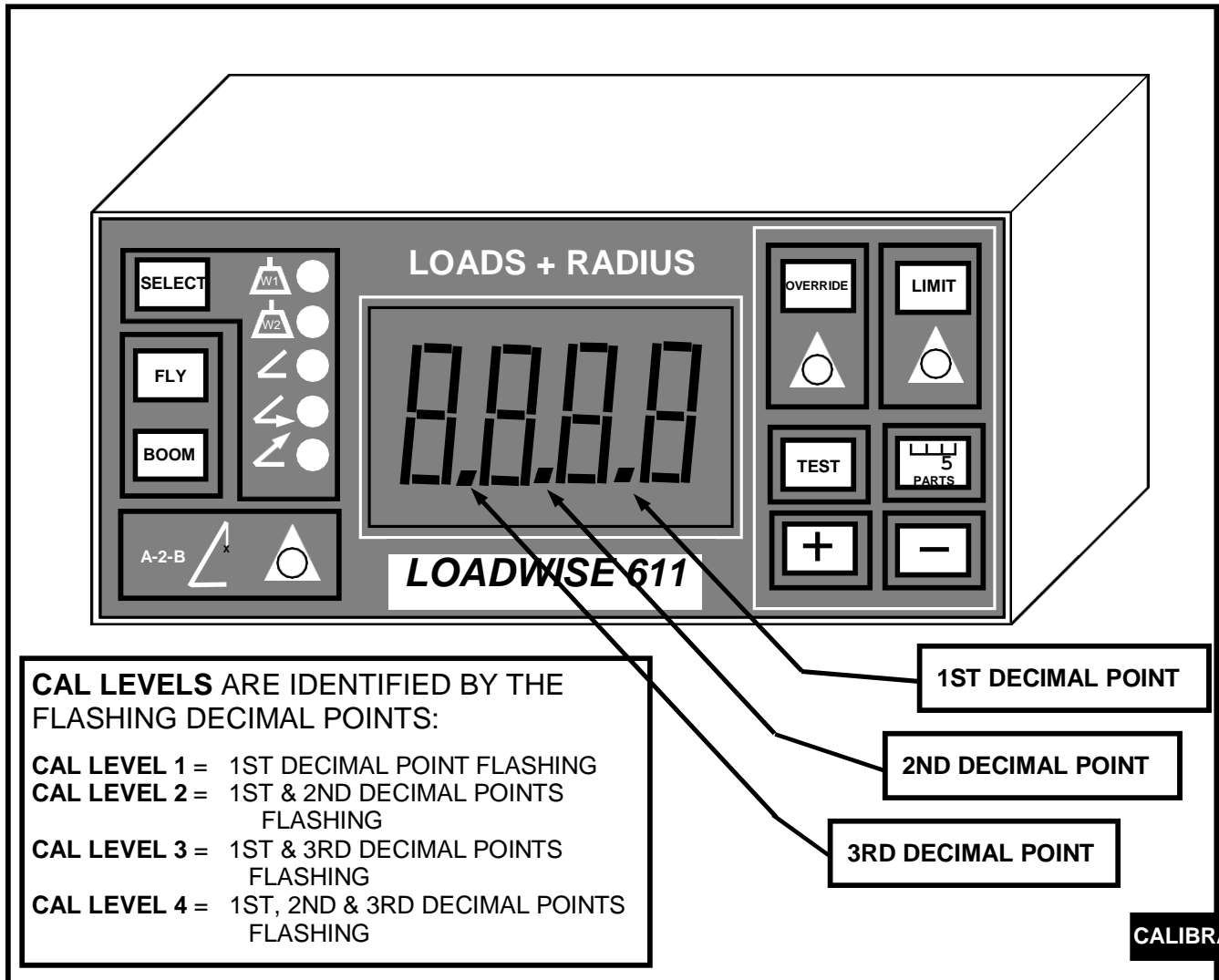

To obtain the correct reading in the display **MODE** and **CAL LEVEL** you are working:

- to change the number by one unit, press "+" or "-".
- to change the number by 10 units, press **PARTS** and "+" or "-" at the same time.
- to change the number by 100 units, press **TEST** and "+" or "-" at the same time.

600

LOADWISE SERIES 600 LOAD, LENGTH, ANGLE RADIUS SYSTEM

Calibration

LOADWISE Series 600 Calibration modes & functions:

- Select the chart for your kind of crane (Telescopic or Lattice Boom)
- Select the mode you want to calibrate
- Identify the function by looking at the flashing decimal points (see page 26)
- Change functions by pressing “+” or “-” while pressing LIMIT until the decimal points blink for the function you are selecting.

**MODEL 610
FOR TELESCOPIC CRANES**

DISPLAY MODE	LEVEL 1 (1st POINT FLASHING)	LEVEL 2 (1st & 2nd POINTS FLASHING)	LEVEL 3 (1st & 3rd POINTS FLASHING)	LEVEL 4 (1st, 2nd & 3rd POINTS FLASHING)
MAIN LOAD	ACTUAL LOAD	MIN LOAD (Hook & Rigging)	MAX LOAD (Test Load + Hook & Rigging)	MAX SINGLE PART LINE PULL
AUX LOAD (IF FITTED)	ACTUAL LOAD	MIN LOAD (Hook & Rigging)	MAX LOAD (Test Load + Hook & Rigging)	MAX SINGLE PART LINE PULL
BOOM ANGLE	ACTUAL BOOM ANGLE	LOW BOOM ANGLE	HIGH BOOM ANGLE	(USED FOR DEFLECTION FOR RADIUS)
BOOM LENGTH	ACTUAL BOOM LENGTH	RETRACTED BOOM LENGTH	EXTENDED BOOM LENGTH	ACTUAL BOOM LENGTH
RADIUS	JIB SELECTED NO JIB =0 OR SELECT JIB # 1 THROUGH JIB # 15	SLEW OFFSET	HEAD OFFSET	ACTUAL RADIUS
RADIUS (WHEN JIB IS SELECTED)		DIMENSION “A”	DIMENSION “B”	DIMENSION “C”

CALIBRATION

“A” = length between the boom head sheave and the jib attachment point (almost always this is zero) - see the drawing on page 30 for further information.

“B” = length of the jib to the attachment point to the sheave edge (almost always this is the actual length of the jib) - see the drawing on page 30 for further information.

“C” = angle of jib offset (even if it is zero) - see drawing on page 30 for further information.

600

LOADWISE SERIES 600 LOAD, LENGTH, ANGLE RADIUS SYSTEM

Calibration

LOADWISE Series 600 Calibration modes & functions:

- Select the chart for your kind of crane (Telescopic or Lattice Boom)
- Select the mode you want to calibrate
- Identify the function by looking at the flashing decimal points (see page 26)
- Change functions by pressing “+” or “-” while pressing LIMIT until the decimal points blink for the function you are selecting.

MODEL 611 FOR LATTICE BOOM CRANES	DISPLAY MODE	LEVEL 1 (1st POINT FLASHING)	LEVEL 2 (1st & 2nd POINTS FLASHING)	LEVEL 3 (1st & 3rd POINTS FLASHING)	LEVEL 4 (1st, 2nd & 3rd POINTS FLASHING)
	MAIN LOAD	ACTUAL LOAD	MIN LOAD (Hook & Rigging)	MAX LOAD (Test Load + Hook & Rigging)	MAX SINGLE PART LINE PULL
	AUX LOAD (IF FITTED)	ACTUAL LOAD	MIN LOAD (Hook & Rigging)	MAX LOAD (Test Load + Hook & Rigging)	MAX SINGLE PART LINE PULL
	BOOM ANGLE	ACTUAL BOOM ANGLE	LOW BOOM ANGLE	HIGH BOOM ANGLE	(USED FOR DEFLECTION FOR RADIUS)
	RADIUS	JIB SELECTED NO JIB = 0	BOOM SELECTED		
			(WHEN BOOM SELECTED = 0)	SLEW OFFSET	HEAD OFFSET
			(WHEN BOOM SELECTED = BOOM # 1 - 15)	BOOM LENGTH	RADIUS
	RADIUS (WHEN JIB IS SELECTED)	(WHEN JIB SELECTED = JIB # 1 - 15)	DIMENSION “A”	DIMENSION “B”	DIMENSION “C”

CALIBRATION

“A” = length between the boom head sheave and the jib attachment point (almost always this is zero) - see the drawing on page 31 for further information.

“B” = length of the jib to the attachment point to the sheave edge (almost always this is the actual length of the jib) - see the drawing on page 31 for further information.

“C” = angle of jib offset (even if it is zero) - see drawing on page 31 for further information.

600

LOADWISE SERIES 600 LOAD, LENGTH, ANGLE RADIUS SYSTEM

Calibration

CALIBRATION NOTES:

- 1) Calibration for all the various models is included in this manual. Please use the appropriate instructions which apply to your model.
- 2) Calibration is performed by selecting the display **MODE** to be calibrated, by pressing the **SELECT** button to light the lamp next to the icon for the display **MODE** to be calibrated, (while in **CAL MODE**,) then selecting the **CAL LEVEL** to be calibrated .
- 3) When calibrating, two functions will be calibrated for each mode. (Example: low boom angle and high boom angle; minimum boom length and maximum boom length; minimum load and maximum load).
- 4) Two “values” or amounts for each display mode must be available. The exact amount is not important but the measurement of the amount is. (Example: minimum load is usually the empty hook block, and maximum load is a site-available load of which the load value is known.) The importance is knowing what the “value” or amount is.
- 5) The load is displayed in 1,000 pound increments. The number on the right of the first or displayed decimal point (one significant digit) is a 100 pound increment. Example: a 5,600 pound load will show on the display as 5.6.
- 6) When calibrating load, first ensure that the parts of line are correctly set for the test load to be lifted.
- 7) When calibrating boom length, first ensure that the unit is not selected with a jib.
- 8) When more than one function is to be calibrated, (all models except 601,) first calibrate the load, then the angle and length (if applicable).
- 9) When calibrating load, first enter the MAX LINE PULL (Level 4), then proceed to MIN LOAD (Level 2) and MAX LOAD (Level 3).
- 10) When calibrating, exercise caution when pressing the “-” button if pressing it will give a negative number or a number below zero. Should this happen, press the “+” button until the display shows the correct number above zero.
- 11) **YOU MUST EXIT THE CALIBRATION MODE (by pressing OVERRIDE and LIMIT) TO SAVE THE CALIBRATION TO THE COMPUTER’S MEMORY. IF THE SYSTEM’S POWER IS SHUT OFF BEFORE PRESSING OVERRIDE AND LIMIT, THE SYSTEM WILL REVERT TO THE PRIOR CALIBRATION.**

CALIBRATION

600

LOADWISE SERIES 600 LOAD, LENGTH, ANGLE RADIUS SYSTEM

Calibration

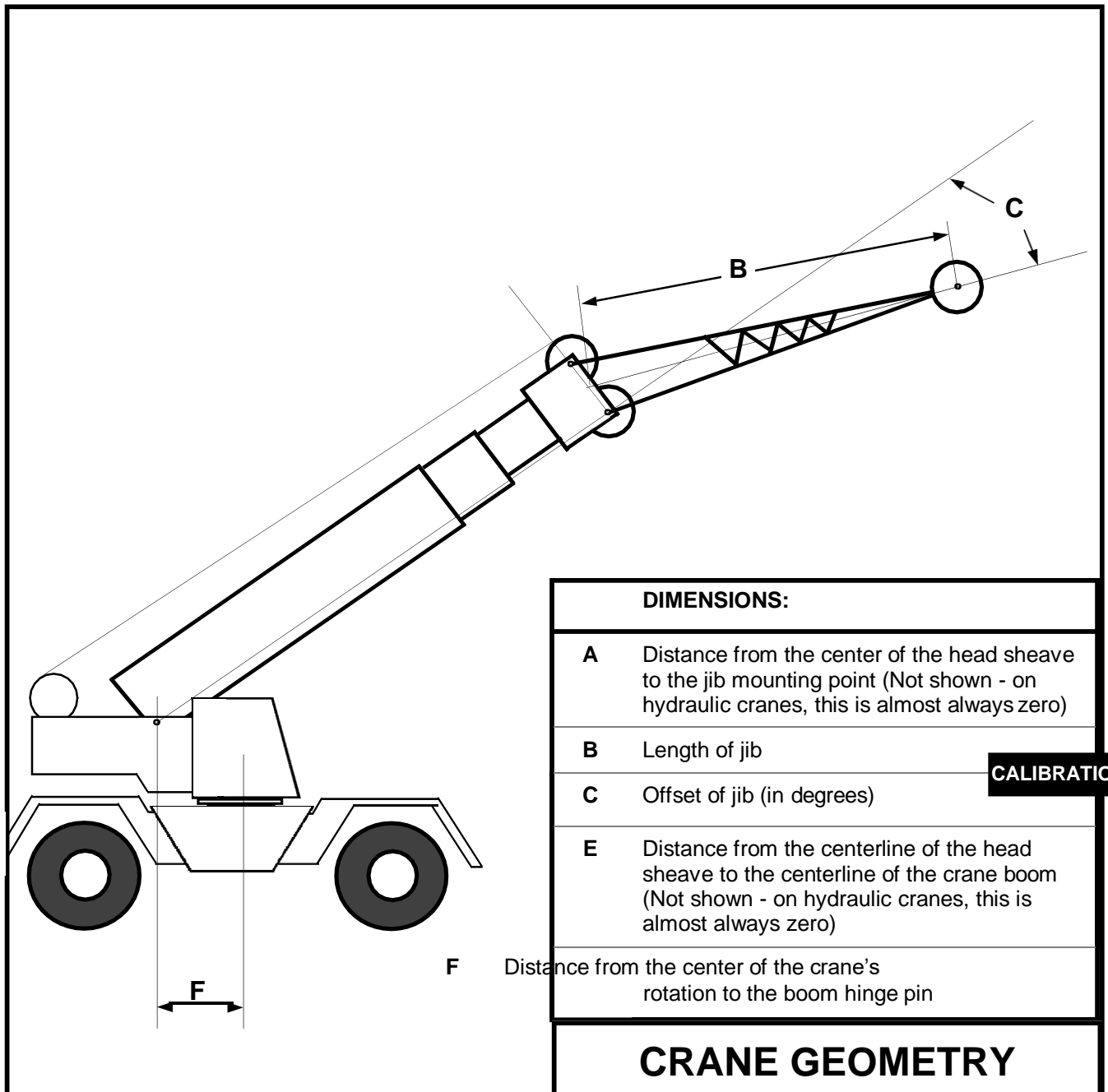

CALIBRATION

600

LOADWISE SERIES 600 LOAD, LENGTH, ANGLE RADIUS SYSTEM

Calibration

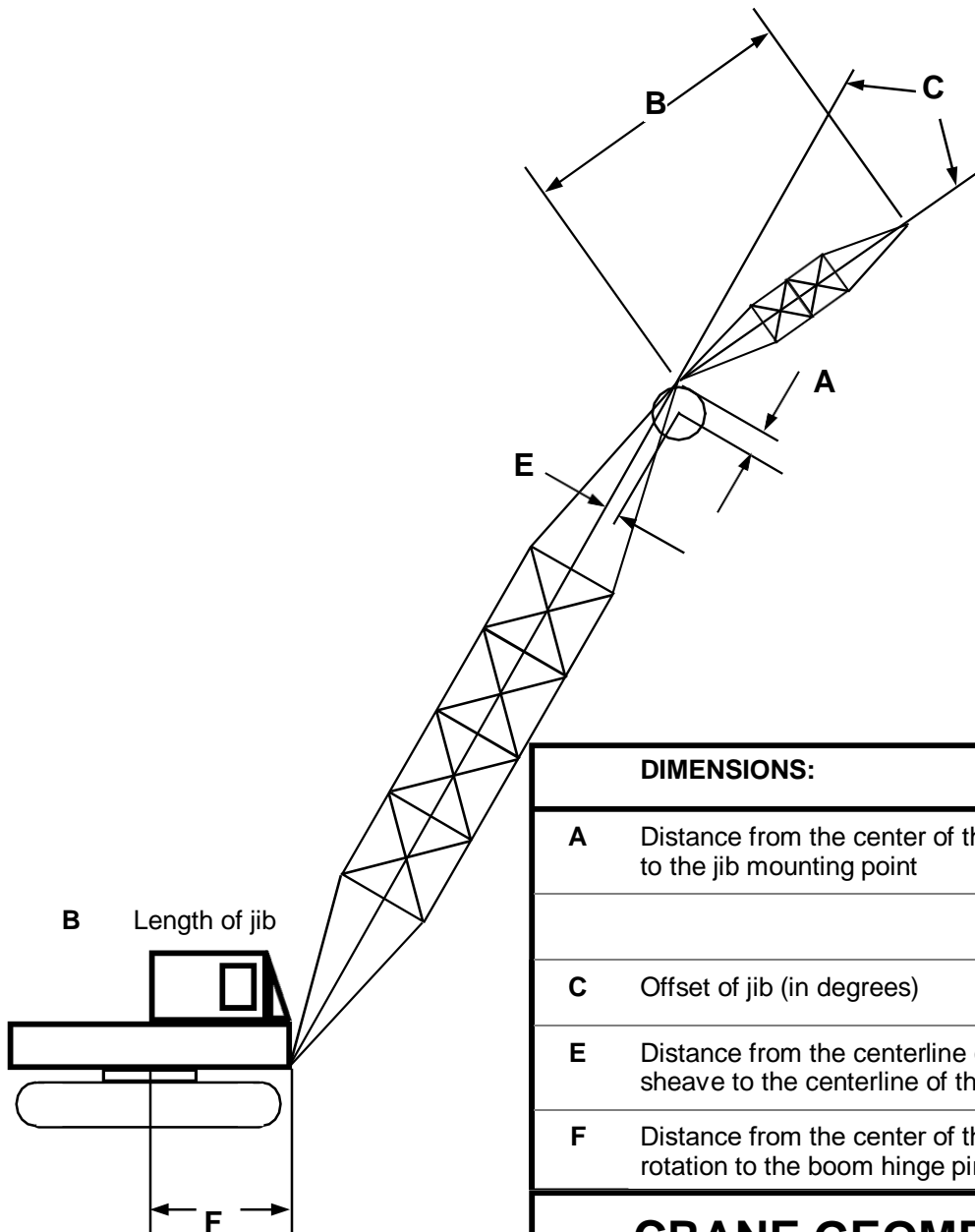

DIMENSIONS:

- | | |
|----------|---|
| A | Distance from the center of the head sheave to the jib mounting point |
| C | Offset of jib (in degrees) |
| E | Distance from the centerline of the head sheave to the centerline of the crane boom |
| F | Distance from the center of the crane's rotation to the boom hinge pin |

CRANE GEOMETRY

600

LOADWISE SERIES 600 LOAD, LENGTH, ANGLE RADIUS SYSTEM

Calibration

LOAD CALIBRATION - Models 601/602/603/604/608/609/610/611

NOTE: For load calibration two loads are required. These are referred to as the minimum and the maximum loads. Normally, the minimum load is the hook block weight plus the line weight, and the maximum load is a weight that is at least two-thirds of the maximum line pull. It is also desirable to have the crane reeved to at least half the possible parts-of-line.

- 1) Select the MAIN or the AUX LOAD display **MODE** by pressing the **SELECT** button until the lamp next to the correct icon is lit.
- 3) Press **PARTS** to confirm the display shows the correct parts-of-line for the load you are calibrating. To change the parts-of-line, press **PARTS** and while holding down the **PARTS** button, press the "+" or the "-" button as applicable. (See page 9.)
- 4) Enter the CAL mode (see page 25).
- 4) In the CAL mode, go to **LEVEL 4** with the 1st, 2nd & 3rd decimal points flashing (see page 26) by pressing the **LIMIT** button and (while holding down the **LIMIT** button) pressing the "+" button as necessary.
- 5) Enter the maximum single-part line pull value by pressing "+" or "-" as required. **NOTE: to make a calibration, the number must be changed even if it is already correct and you have to change it back.** (For example, a maximum single-part line pull of 9,600 lbs is entered as ..9.6)
- 6) Pick up the minimum load (i.e. the hook block and rigging only).
- 7) Change to **LEVEL 2** with the 1st & 2nd decimal points flashing.
- 8) Enter the minimum load value by pressing "+" or "-" as required. (For example, a hook block and rigging weight of 2,300 lbs is entered as .2.3)
- 9) Next, pick up the known test (or maximum) load. **Remember to include the weight of the hook block and rigging when determining your maximum load.**
- 10) Change the display to **LEVEL 3** with the 1st & 3rd decimal points flashing.
- 11) Enter the maximum load value by pressing "+" or "-" as necessary. (For example, a test load of 25,000 lbs plus a hook block and rigging weight of 2,300 lbs (total load of 27,300 lbs) is entered as .27.3)
- 12) Change the display to **LEVEL 1** with the 1st decimal point flashing - this will display the actual load without leaving the **CAL** mode. Put the load down and check the minimum load and then pick up the maximum load again to check maximum. If necessary, repeat steps 4 through 9 and adjust accordingly.

CALIBRATION

600

LOADWISE SERIES 600 LOAD, LENGTH, ANGLE RADIUS SYSTEM

Calibration

ANGLE CALIBRATION - Models 602/604/605/606/608/609/610/611

- 1) Enter the CAL mode (if not already done)
- 2) Press **SELECT** on the display until the lamp is lit next to the ANGLE icon, to access the ANGLE mode. (At this point in time the display will not be correct until the calibration is completed.)
- 3) Move the boom to a low known angle. This angle must be a positive number, (above 0°,) such as 5° or 10°.
- 4) Go to **LEVEL 2** by holding down the **LIMIT** button and pressing “+” or “-” until the first and second decimal points flash.
- 5) Enter the actual (known low) boom angle by using the “+” or “-” buttons as required. (For example, a 5° angle is entered as .5.0)
- 6) Move the boom to a high (known) angle.
- 7) Go to **LEVEL 3** by holding down the **LIMIT** button and pressing “+” or “-” until the first and third decimal points flash.
- 8) Enter the actual (known high) boom angle by using the “+” or “-” buttons as required. (For example, a 65° angle is entered as .65.0)
Note: when the first, second and third decimal points are flashing the unit is in the boom angle deflection adjustment function. This function is used to correct radius changes due to boom deflection, and will be accessed later on in the calibration process.
- 9) Go to Level 1 by holding down the LIMIT button and pressing “+” or “-” until the first decimal point flashes. This will display the actual boom angle, and is a provision for verifying the display boom angle is correct without leaving the CAL mode.

CALIBRATION

600

LOADWISE SERIES 600 LOAD, LENGTH, ANGLE RADIUS SYSTEM

Calibration

BOOM LENGTH CALIBRATION - Models 605/608//610

- 1) Enter the CAL mode (if not already done)
- 2) Press **SELECT** on the display until the lamp is lit next to the LENGTH icon, to access the LENGTH mode.
- 3) Fully retract the boom (manual section in also).
- 4) Go to **LEVEL 2** by holding down the the **LIMIT** button and pressing “+” until the first and second decimal points flash.
- 5) Enter the actual (retracted) boom length by using the “+” or “-” buttons as required. (For example, a retracted boom length of 35 ft is entered as .3.5.0)
- 6) Go to **LEVEL 3** by holding down the **LIMIT** button and pressing “+” until the first and third decimal points flash.
- 7) Fully extend the boom.
- 8) Enter the actual (extended) boom length by using the “+” or “-” buttons as required. (For example, an extended boom length of 85 ft is entered as .85.0)
- 9) Go to **LEVEL 4** by holding down the **LIMIT** button and pressing “+” until the first, second and third decimal points flash. This will display the calibrated boom length. Telescope fully in and out to check that the length display correctly follows the boom movement.

CALIBRATION

600

LOADWISE SERIES 600 LOAD, LENGTH, ANGLE RADIUS SYSTEM

Calibration

BOOM LENGTH on LATTICE BOOM CRANES - Models 606/611

There are fifteen possible main boom lengths that can be preset into the indicator. These are numbered 1 through 15 and each boom length to be used must be entered into the indicator for the operator selection to appear. It is useful to make a chart of the boom lengths, for referral later. An example is at the bottom of this page.

To set the boom lengths into the display:

- 1) Enter the CAL mode (if not already done)
- 2) Press **SELECT** on the display to light the lamp next to the icon for RADIUS. (Be sure that the fly jib or jib is NOT selected.) At this point you will be at **LEVEL 1** with the first decimal point flashing, and the flyjib or jib number "0.0" will be displayed - if not, press "+" or "-" until "0.0" is displayed.
- 3) Enter the actual boom length for each number (1 through 15) by:
 - A) Go to **LEVEL 2** by holding down the **LIMIT** button and pressing "+" until the first and second decimal points are flashing.
 - B) Enter the boom number (1 through 15) by pressing "+" or "-" as required.
 - C) Go to **LEVEL 3** by holding down the **LIMIT** button and pressing "+" until the first and third decimal points are flashing.
 - D) Enter the boom length by using the "+" or "-" buttons. If you want to change the display by larger increments, press **PARTS** and "+" or "-" at the same time (to change the number by 10 units) or press **TEST** and "+" or "-" at the same time (to change the number by 100 units). (See page 26.) (For example, a 100 ft boom length is entered as 1.00.0)
 - E) Go to **LEVEL 2** by holding down the **LIMIT** button and pressing "+" until the first and second decimal points are flashing, and follow Steps B through E as above for each boom length on your chart of boom lengths.

CHART OF BOOM LENGTHS

Boom #	Boom Length
1	50 FT BOOM
2	60 FT BOOM
3	70 FT BOOM
4	80 FT BOOM
5	90 FT BOOM
ETC.	ETC. (15 COMBINATIONS POSSIBLE)

CALIBRATION

600

LOADWISE SERIES 600 LOAD, LENGTH, ANGLE RADIUS SYSTEM

Calibration

RADIUS CALIBRATION - Models 605/606/610 **except 611**

- 1) Enter the CAL mode (if not already done)
- 2) Press **SELECT** on the display until the lamp is lit next to the RADIUS icon, to access the RADIUS mode. ENSURE THAT NO FLY JIB OR JIB CONFIGURATION IS SELECTED (by pressing FLY and confirming that the display reads "0" while pressed).
- 3) Go to **LEVEL 4** by holding down the **LIMIT** button and pressing "+" or "-" until the first, second and third decimal points are flashing. This will display the RADIUS.
- 4) Go to **LEVEL 2** by holding down the **LIMIT** button and pressing "+" or "-" until the first and second decimal points are flashing.
- 5) Enter the SLEW OFFSET (Dimension F on the drawing on page 30) by pressing the "+" or "-" button as required. (The SLEW OFFSET is the horizontal distance from the center of rotation of the crane to the boom pivot pin.) The system automatically adds this number for Lattice Boom cranes and subtracts this number for Hydraulic cranes, so no "+" or "-" sign is necessary when entering the slew offset. (For example, a 3 ft Slew Offset is entered as .3.0)
- 6) Go to **LEVEL 3** by holding the **LIMIT** button and pressing "+" or "-" until the first and third decimal points are flashing.
- 7) Enter the BOOM HEAD SHEAVE OFFSET (Dimension E on the drawing on page 30) by pressing the "+" or "-" button as required. This is always either a positive number or it is zero (a negative number is not possible). (For example, a 6" Boom Head Sheave Offset is entered as .0.5)

600

LOADWISE SERIES 600 LOAD, LENGTH, ANGLE RADIUS SYSTEM

Calibration

RADIUS CALIBRATION - Models 611 (MAIN BOOM)

- 1) Enter the CAL mode (if not already done)
- 2) Press **SELECT** on the display until the lamp is lit next to the RADIUS icon, to access the RADIUS mode.
- 3) Go to **LEVEL 1** by holding down the **LIMIT** button and pressing “+” or “-” until the first decimal point is flashing. This will display the Fly Jib or Jib combination “0”. If necessary, press “+” or “-” until the display shows “0”.
- 5) Go to **LEVEL 2** by holding down the **LIMIT** button and pressing “+” or “-” until the first and second decimal points are flashing - this will now display the boom number. Select boom # 0 by pressing “+” or “-” if necessary.
- 6) With both Fly # 0 and Boom # 0, go to **LEVEL 3** by holding down the **LIMIT** button and pressing “+” or “-” until the first and third decimal points are flashing - this will now display the SLEW OFFSET (dimension F on the drawing on page 31). (For example, a 3 ft Slew Offset is entered as . 3.0)
- 7) If necessary, press “+” or “-” to enter the correct slew offset. (The SLEW OFFSET is the horizontal distance from the center of rotation of the crane to the boom pivot pin. The system automatically adds this number for Lattice Boom Cranes, so no “+” or “-” sign is necessary when entering the slew offset.)
- 8) Next, go to **LEVEL 4** by holding down the **LIMIT** button and pressing “+” or “-” until the first, second and third decimal points are flashing - this will now display the BOOM HEAD SHEAVE OFFSET (dimension E on the drawing on page 31).
- 7) If necessary, press “+” or “-” to enter the correct boom head sheave offset. This is always either a positive number or zero (a negative number is not possible). (For example, a 1 ft Boom Head Sheave Offset is entered as ..1.0)

600

LOADWISE SERIES 600 LOAD, LENGTH, ANGLE RADIUS SYSTEM

Calibration

FLY JIBS AND JIBS - Models 605/606/610/611

There here are fifteen possible fly jib or jib configurations that can be preset into the indicator. (A fly jib or jib configuration is a combination of jib length and offset angle.)

These are numbered 1 through 15 and each configuration to be used must be entered into the indicator for the operator selection to appear. Configuration "0" is reserved for NO FLY JIB or NO JIB. To set the fly jib or jib configurations into the display:

- 1) List the fly jib or jib configurations and assign each a number.

For example:

No. 0 = NO FLY JIB OR JIB INSTALLED (cannot be calibrated)

No. 1 = 32 ft. jib at 0° offset

No. 2 = 32 ft. jib at 15° offset

No. 3 = 32 ft. jib at 30° offset

No. 4 = 46 ft. jib at 0° offset etc.

- 2) Enter the CAL mode (if not already done)
- 3) Press **SELECT** on the display until the lamp is lit next to the RADIUS icon.
- 4) Go to **LEVEL 1** by holding down the **LIMIT** button while pressing "+" until the first decimal point is flashing. Next, press "+" or "-" until the FLY JIB or JIB number you want to enter is displayed (1-15).
- 5) Set the configuration by entering three pieces of information on each configuration:
Dimension A = the length between the boom head sheave and the jib attachment point.
Dimension B = the length of the fly jib or jib to the attachment point to the sheave edge (almost always this is the actual length of the jib).
Dimension C = the angle of the offset of the fly jib or jib (even if it is zero).

To enter this data:

- A) Go to **LEVEL 2** by holding down the **LIMIT** button while pressing "+" until the first and second decimal points are flashing,
- B) Enter Dimension A by pressing "+" or "-" as required. (1 ft is entered as .1.0)
- C) Go to **LEVEL 3** by holding down the **LIMIT** button while pressing "+" until the first and third decimal points are flashing.
- D) Enter Dimension B by pressing "+" or "-" as required. (30 ft is entered as .30.0)
- E) Go to **LEVEL 4** by holding down the **LIMIT** button while pressing "+" until the first, second and third decimal points are flashing.
- F) Enter Dimension C by pressing "+" or "-" as required. (15° is entered as .1.5.0)
- G) Return to **LEVEL 1** by holding down the **LIMIT** button while pressing "+" until the first decimal point is flashing. (This will display the fly jib or jib number.
- H) Select the next Fly Jib or Jib configuration, and repeat steps A) through G) for each Fly Jib or Jib configuration.

CALIBRATION

600

LOADWISE SERIES 600 LOAD, LENGTH, ANGLE RADIUS SYSTEM

Calibration

BOOM DEFLECTION - Model 605/610 (Telescopic Cranes) Only

The facility for modifying the radius display to compensate for boom deflection or bending is as follows:

- 1) Ensure that no fly jib or jib is selected (by pressing the FLY button - the display will show "0.0"). If the display does not show "0.0", press the FLY button and while holding it down, press the "-" button until the display shows "0.0".
- 2) Enter the CAL mode (if not already done)
- 3) Press **SELECT** on the display until the lamp is lit next to the ANGLE icon.
- 4) Go to **LEVEL 4** by holding down the **LIMIT** button and pressing "+" or "-" until the first, second and third decimal points are flashing. This will display the actual calculated radius, which can be modified now that the crane's geometry has been entered.
- 5) Measure the crane's actual radius, preferably with the boom at appx. 60°, fully telescoped, with rated load suspended, ensuring that the crane is set up level.
- 6) If necessary, press "+" or "-" to enter the correct radius. If you want to change the display by larger increments, press **PARTS** and "+" or "-" at the same time (to change the number by 10 units) or press **TEST** and "+" or "-" at the same time (to change the number by 100 units). (See page 26.)

600

LOADWISE SERIES 600 LOAD, LENGTH, ANGLE RADIUS SYSTEM

Calibration

ANALOG MODE

The analog mode is a service-level tool used for looking at the analog inputs from the sensors, which may be useful to determine an out-of-range or faulty sensor. Accessing the analog mode does not affect the calibration already made.

To access this mode:

Ensure that the power to the unit has been turned off.

To examine the raw data inputs from the sensors:

- 1) Power down the system.
- 2) Hold the “+” and the “-” buttons on and power up the system; the display will show “ANA” to show the analog display has been activated.
- 3) The A2B input is operational in this mode and cannot be overridden.
- 4) All four analog inputs will be displayed in the following order
 - LOAD 1
 - LOAD 2
 - ANGLE
 - LENGTH
- 5) To select the input to be displayed, press “+”. The icon lamps on the left side will indicate which input is displayed, irrespective of decal.
- 6) While in this mode, the following items are suppressed:
 - ALL LIMIT MESSAGES
 - ALL FAULT MESSAGES
 - ALL ALARMS EXCEPT THE FINAL OUTPUT FOR A2B
 - ALL SWITCHES EXCEPT “+”