

MICROGUARD® 424
RATED CAPACITY INDICATOR SYSTEM

OPERATION/TROUBLESHOOTING
MANUAL

TELESCOPIC BOOM CRANES

HORIZONTAL DISPLAY



PSR Professional Service & Repair Inc.

Professional Service & Repair Inc. is a full-service mobile crane repair, inspection, and certification company. At Professional Service & Repair we understand the critical aspect of your crane being operational to your project schedule and budget. We will deliver world class service to have your crane operational in the minimum amount of time.

PSR is the global provider for sales, repair and installation of Load Moment Indicating (LMI) systems, Anti-Two Block Systems (A2B), and Rated Capacity Indicating systems. Please contact us with your crane repair and certification needs today.

PSR is the name businesses trust for crane repair, inspection, and certification.

Main Line: 706-718-0856

Fax: 706-569-7004

E-Mail: jeff@psrinc.biz

**P.O. Box 6506
Columbus, GA
31917-6506**

MICROGUARD[®] 424
RATED CAPACITY INDICATOR SYSTEM
OPERATION/TROUBLESHOOTING MANUAL
TABLE OF CONTENTS

SECTION 1: OPERATION

MICROGUARD[®] 424 SYSTEM DESCRIPTION.....4

DISPLAY WINDOWS.....5-6

PUSH BUTTONS - ICONS - LAMPS - ALARMS.....7-10

MICROGUARD[®] 424 SYSTEM OPERATION.....11

CONFIGURATION SELECTION12-15

EXAMPLES OF CRANE SET UP16-20

MAIN BOOM.....16

MAIN BOOM PLUS 35' OFFSETTABLE FLY.....17

MAIN BOOM PLUS 48' TELESCOPING FLY.....18

ON TIRES.....19

RIGGING/TRAVEL MODE20

OPERATOR SETTABLE ALARMS.....21-24

METHOD OF SETTING.....22

EXAMPLES OF SETTING ALARMS.....23-24

CANCELING ALARMS24

PERIODIC INSPECTIONS.....25-26

CHECKING THE ANTI TWO-BLOCK SYSTEM.25-26

ROUTINE MAINTENANCE.....26

SECTION 2: TROUBLESHOOTING.....27-51

MICROGUARD[®] 424 SYSTEM DESCRIPTION

This manual describes the function and operation of the MicroGuard[®] 424 Rated Capacity Indicator (RCI) System for telescopic boom cranes. The MicroGuard[®] 424 System is intended to aid the crane operator in efficient crane operation by continuously monitoring the load and warning of an approach to an overload or a two-block condition. This System, which monitors crane functions by means of high accuracy sensors, continuously compares the load suspended below the boom head with data from a copy of the crane capacity chart, stored in the computer memory. If an overload is approached, the MicroGuard[®] 424 System warns the operator by means of audible and visual alarms and can be configured to cause function kick-out.

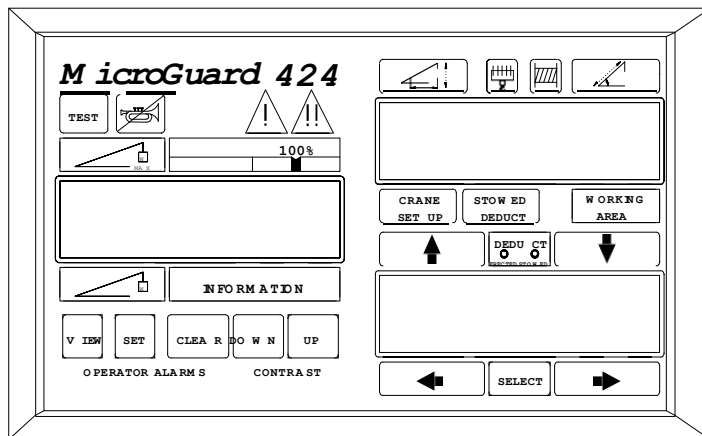

The MicroGuard[®] 424 indicator provides the operator with a continuous display of:

- ◆ Rated Capacity
- ◆ Actual Load
- ◆ Percentage of Rated Capacity
- ◆ Radius of the Load
- ◆ Angle of the Main Boom
- ◆ Working Area
- ◆ Crane Configuration

And by means of alternate display push buttons, it provides the operator with:

- ◆ Length of the Main Boom
- ◆ Height of the Boom Head

On-screen messages provide the operator with visual indications of the various alarms, which may occur during normal operation of the MicroGuard[®] 424 System. These values are displayed on the left and upper right display. The lower right display gives information about the currently selected crane configuration.

DISPLAY WINDOWS

LEFT DISPLAY WINDOW

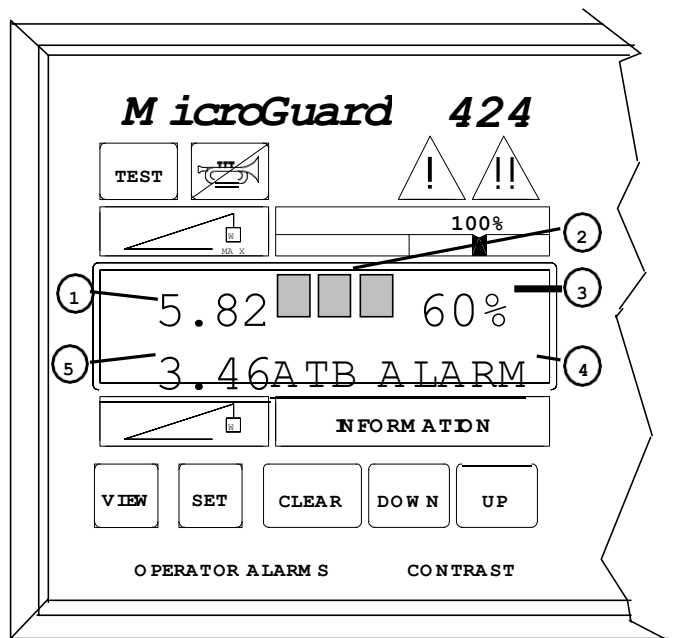

1 **MAXIMUM RATED CAPACITY** is a digital display of the maximum permitted capacity. It is derived from the crane's capacity chart. A copy of this chart is stored in the computer memory and is the reference capacity for any lifting operation. Maximum Rated Capacity is dependent on the configuration currently selected. This configuration, shown in the lower right display, determines the section of the capacity chart to be used as the capacity reference. If maximum rated capacity is limited by parts of line, then the displayed **MAXIMUM RATED CAPACITY** is the rope capacity and the message, "ROPE LIMIT" is displayed in the information area.

- 2** The **BAR GRAPH** is an analog bar graph in the upper display that gives a visual indication of how much of the crane capacity is being used and the rate at which an overload is being approached. This bar graph in conjunction with the 100% capacity marker gives a visual indication of when the overload point is reached.
- 3** **PERCENTAGE OF RATED CAPACITY** is a part of the bar graph display. A digital readout within the bar graph display expresses Actual Load as a percentage of Maximum Rated Capacity. For percentages of less than 100%, the display will be at the right side of the bar graph. For percentages over 87%, the display will move to the center of the bar graph in order to make space for the leading edge of the bar graph.
- 4** The **INFORMATION AREA** provides the operator with a visual indication of the various alarms, which may occur during normal operation of the MicroGuard® 424 System. For example, PRE-ALARM or OVERLOAD, ATB ALARM, and ROPE LIMIT.
- 5** **ACTUAL LOAD** is a digital display that shows total load suspended below the boom or jib head. It includes the load, slings, pins or tackle used to secure the load and the hook block.

DISPLAY WINDOWS

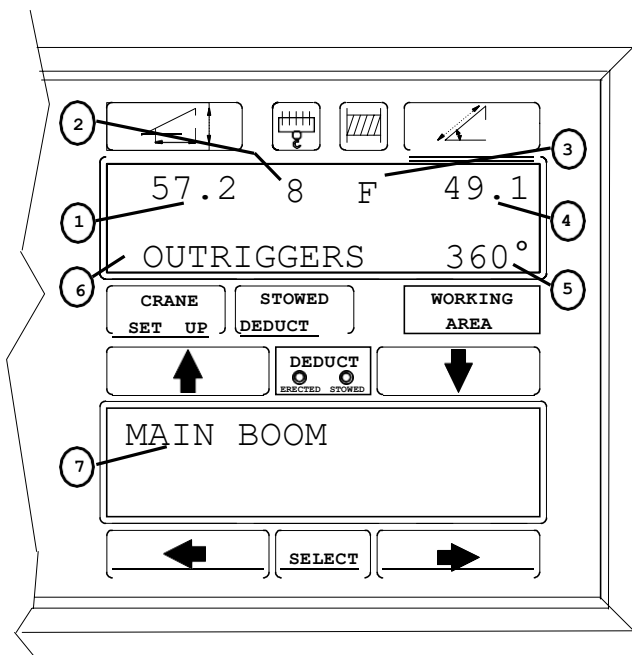

RIGHT SIDE DISPLAYS

- 1 The **RADIUS/HEIGHT** display gives a continuous indication of the radius of the load, which is the horizontal distance from the centerline of rotation to the centerline of the hook. When the Radius/Height push button is pressed, the display will give a momentary readout of the height of the boom head above ground level i.e., the vertical distance from the ground to the boom/jib head. Information about height is only displayed while the Radius/Height push button is pressed and held.
- 2 The **PARTS OF LINE** display shows the parts of line currently selected. If the parts of line selected has a lower safe working strength than the actual capacity, the **MAXIMUM RATED CAPACITY** display will show the reduced

capacity and the message, "ROPE LIMIT" will appear in the information area.

- 3 The **WINCH IN USE** display indicates the selected winch. "F" indicates front; "R" indicates rear.
- 4 The **ANGLE/LENGTH** display gives a continuous indication of the angle of the main boom relative to horizontal. When the angle/length push button is pressed and held, the display will give a momentary readout of the length of the Main Boom from the boom foot pin to the shaft of the head machinery. Information about length is shown only while the Angle/Length push button is pressed and held.
- 5 The **WORKING AREA** is located in the lower right of the middle display. Descriptions conform to the current configuration selected and to the swing position of the crane upper. For example, the following messages will appear:
 Front, Side, Rear, 360°
 Line, Track (between tracks)
- 6 The **OUTRIGGERS** or **TIRES** display is located in the lower left of the middle display. Readout is determined by the current duty selection.
- 7 The **LIFTING POINT** is continuously shown in the lower display. If an attachment such as a fly is erected but is not the lifting point, the DEDUCT (see Push Buttons, Icons, and Lamps) light will be illuminated.

PUSH BUTTONS - ICONS - LAMPS - ALARMS

LEFT DISPLAY

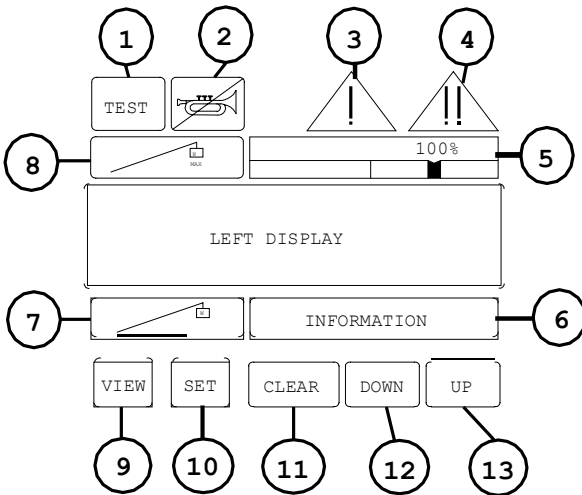

- 1 TEST** is a push button used to initiate a system self-test; it is also used to display fault codes.
- 2 CANCEL ALARM** is a push button used to silence the audible alarm when the alarm has occurred as a result of either an Overload, an Anti Two-Block alarm, or an Operator Settable alarm. CANCEL ALARM is also used to reset the function kick-out relay when it is necessary to by-pass function kick-out.
- 3** The **PRE-ALARM (AMBER)** indicator illuminates at a pre-set value of 90% of Maximum Rated Capacity and provides a visual indication of an approach to an overload.
- 4** The **OVERLOAD INDICATOR (RED)** illuminates at a pre-set value of 100% of Maximum Rated Capacity and provides a visual indication of Maximum Allowed Load. The OVERLOAD INDICATOR will also illuminate whenever an anti two-block (A.T.B.) alarm occurs or a wire rope limit is exceeded or an operator SETTABLE alarm has been reached or exceeded. When the crane is equipped with function kick-out, this will occur simultaneously for an Overload, Wire Rope Limit, or an Anti Two-Block condition, but function kick-out will not occur when exceeding an operator set alarm.
- 5** The **BAR GRAPH ICON** is a part of the analog bar graph in the upper display. This display bar graph gives a visual indication of how much of the crane's capacity is being used and the rate at which an overload is being approached. The leading edge of the bar graph aligns with three colored bands in the bar graph indicator. Red indicates an overload. Between the red and amber is a black notch, which indicates 100% of rated capacity. The **100% RATED CAPACITY** indicator is above the bar graph in the upper display and marks the point at which 100% of the rated capacity of the crane has been reached. When the value of 100% has been reached, it corresponds to the Maximum Rated Capacity in the upper display.
- 6** The **INFORMATION AREA** indicates the area of the upper display that provides the operator with a visual indication of the various alarms, which may occur during normal operation of the system.
- 7** The **ACTUAL LOAD ICON** indicates the area of the display that shows the total load suspended below the boom, fly, or jib head. It includes the load, any slings, pins or tackle used to secure the load and also includes the weight of the hook block.
- 8** The **MAXIMUM RATED CAPACITY** icon indicates the area of the upper display that gives a readout of maximum rated capacity for the currently selected configuration.

OPERATOR ALARM BUTTONS AND CONTRAST

- 9 VIEW** is a push button used during the setting of operator alarms. It is used to start the routine and to view the current alarm settings.
- 10 SET** is a push button used during the setting of operator alarms to set a new alarm setting.
- 11 CLEAR** is a push button used during the setting of operator alarms to clear the current alarm setting.
- 12 CONTRAST (DOWN)** is a push button used to decrease the display contrast.
- 13 CONTRAST (UP)** is a push button used to increase the display contrast.

UPPER RIGHT DISPLAY

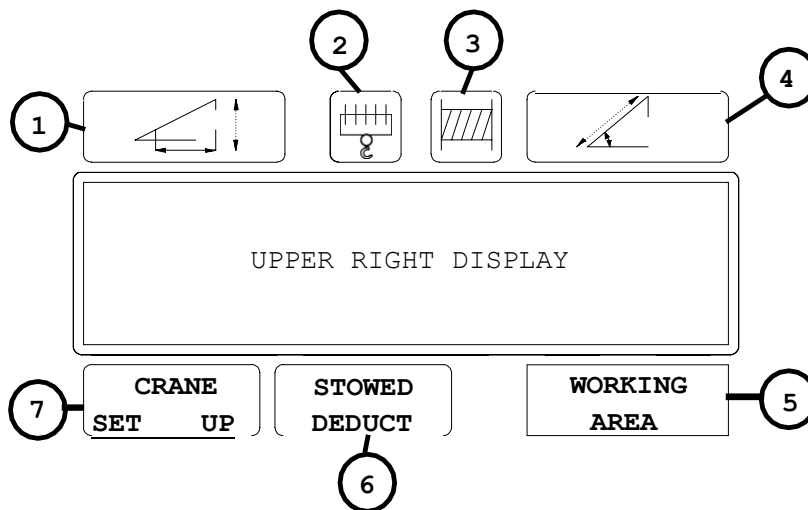

1 The **RADIUS/HEIGHT** icon indicates the area of the display that gives a readout of radius and height. This icon is also a push button used to select the alternate display of height.

HEIGHT is displayed only when the push button is pressed and held. When this push button is not pressed, the display readout is always the radius of the load.

2 The **PARTS OF LINE** icon indicates the area of the display

that gives a read-out of the parts of line currently selected. This icon is also a push button used to select the parts of line in use on the selected winch.

3 The **WINCH SELECT** icon indicates the area of the display that gives a readout of the winch currently selected. This icon is also the push button used to select the Front or Rear winch. When switching between winches, the parts of line previously selected for the other winch is recorded and displayed whenever the alternate winch is selected.

4 The **ANGLE/LENGTH** icon indicates the area of the display that gives a read-out of angle or length. This icon is also a push button used to select the alternate display of Length. Length is displayed only when the push button is pressed and held. When this push button is not pressed, the display will always show the Angle of the main boom.

5 **WORKING AREA** indicates the part of the display where messages can be displayed. Messages in this area will conform to the current duty selection and the swing position of the crane upper.

6 **STOWED DEDUCT** is a push button that is used to start the selection of deducts for stowed attachments. The first press of the button will start the menu, after which it will function as a down-arrow for scrolling.

7 **CRANE SET UP** indicates the area of the display showing a read-out of the currently selected crane configuration (on **OUTRIGGERS** or **TIRES**). **CRANE SETUP** is also a push button used to start the selection of configurations.

LOWER RIGHT PUSH BUTTONS AND ICONS

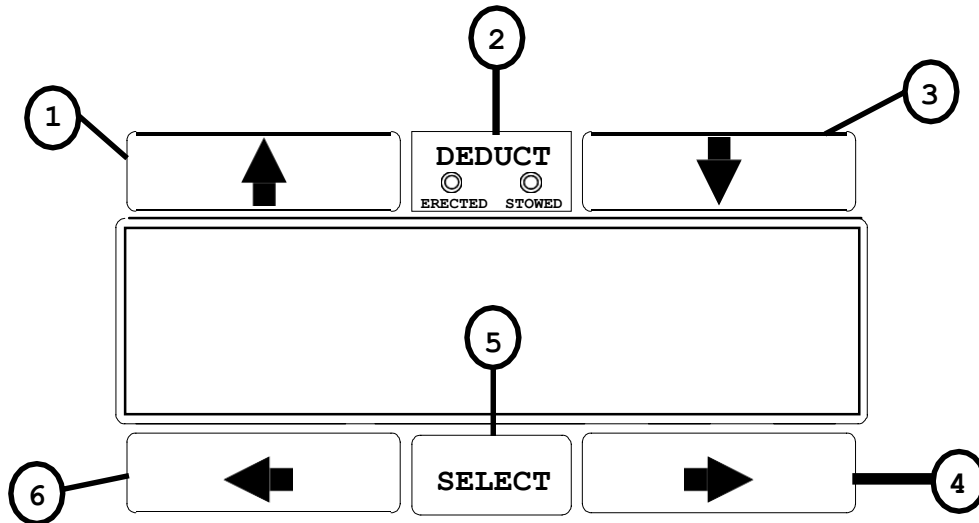

- 1 and 3** **UP/DOWN ARROWS** are push buttons used as arrows for scrolling.
- 2** **DEDUCT INDICATOR** is an icon that contains two amber lamps, which indicate stowed and erected deducts. When a deduct is selected, the appropriate lamp will illuminate to warn the operator that a deduct has been applied.
- 4 and 6** **RIGHT and LEFT ARROW** are push buttons used in calibration routines.
- 5** **SELECT** is a push button used to terminate all selection and calibration routines.

MICROGUARD® 424 SYSTEM OPERATION

At start-up, the MicroGuard® 424 System automatically performs a self-test. Upon completion of the self-test, the System goes directly to the normal working screen. The self-test can be initiated at any time during normal operation by pressing the TEST button.

TEST

One press (press and release) will cause the system to execute a self-test routine during which all lamps, audible alarms, and digital displays will be functionally tested, and all memory areas will be checked for accuracy. If faults in the system are detected during a test, the information area in the upper display will show the word **FAULT**. If the word FAULT occurs, press and *hold* the TEST button. This will cause the display to change to the FAULT mode. In this mode, information about the fault condition will be displayed in the middle display by means of an error code.

CANCEL ALARM

CANCEL ALARM is used to cancel the audible alarm when the alarm has occurred as a result of either an Overload, an Anti Two-Block alarm (A.T.B.) or an Operator Settable alarm. The audible alarm may be canceled by pressing and releasing the CANCEL ALARM button. **The audible alarm remains canceled until the condition, which caused the alarm, has been removed.** For example, if the audible alarm was canceled because of an overload condition, it will remain canceled until the overload condition is removed. However, if a different alarm (e.g., an anti two-block condition) was to occur when the audible alarm was still canceled for an earlier overload condition, the new alarm condition would cause the audible alarm to be restarted.

CANCEL ALARM is also used to reset the function kick-out relay when it is necessary to by-pass a function kick-out that has occurred as a result of either an overload or an A.T.B. alarm. The relay is reset by first canceling the audible alarm [as described above] and then pressing and holding the CANCEL ALARM button for about 3 seconds, after which the function kick-out relay will be set to normal operation. However, should another different alarm condition occur when the relay had previously been overridden, then the newly occurring alarm condition would cause the motion cut to be restarted.

CANCEL ALARM is a temporary function. The audible alarm or function kick-out is automatically reset when the condition that caused the alarm is no longer present.

WARNING

WHEN FUNCTION KICK-OUT IS RESET BY MEANS OF THE CANCEL ALARM BUTTON YOU ARE NO LONGER PROTECTED AGAINST THE CONDITION THAT CAUSED THE FUNCTION KICK-OUT.

CONFIGURATION SELECTION

In the normal operational mode, the MicroGuard® 424 System is programmed to retain the configuration last selected. Each time the system is powered up, it will automatically choose that configuration. Only when the crane is rigged differently must a new configuration be selected.

CRANE SET UP

The menu for the crane set up consists of up to 7 consecutive steps. Steps that are not available are automatically skipped by the program during the Crane Set Up procedure.

1. Select Outriggers, Tires, Rigging/Travel mode.
2. Select Counterweight configuration (If available).
3. Select Boom configuration or Telescope Mode (If available).
4. Select Auxiliary Head fitted or not fitted.
5. Select Lifting Attachments.
6. Select Lifting Point for Front Winch.
7. Select Lifting Point for Rear Winch.

AFTER THE SELECTIONS MADE DURING CRANE SET UP, IT IS ONLY NECESSARY TO USE THE WINCH PUSH BUTTON TO SELECT THE LIFTING POINT. ALL OF THE INFORMATION REQUIRED BY THE SYSTEM IS ENTERED DURING CRANE SET-UP. THE PARTS OF LINE IN USE FOR EACH WINCH MUST ALSO BE SET FOR THE SYSTEM TO OPERATE CORRECTLY.

FOR SPECIFIC EXAMPLES OF CRANE SET-UP, REFER TO PAGES 16-20.

PARTS-OF-LINE

Press and hold the PARTS-OF-LINE push button to scroll through the available parts of line. The new value is automatically registered when the button is released. The number chosen applies only to the winch currently selected and a value must be programmed for both winches.

WINCH

The current selection is shown in the display by use of the letter F for front winch and the letter R for rear winch. To change the selection, press the WINCH select push button. Successive pressing of the button will change the selection from one to the other. After the initial setup, the system retains the Parts-of-Line and Lifting Point and Deducts for each winch.

RIGGING TRAVEL MODE

The Rigging /Travel mode is selected as part of the carrier options. This mode is used to facilitate the rigging and travel of the crane by inhibiting motion-cut and audible alarm while selected. The information screen is restricted to the display of radius, length, angle, height and precautionary messages during the time that the mode is selected. *To return to normal operation, press CRANE SET UP.*

STOWED DEDUCTS

When attachments such as flys are stowed, it is necessary to make a reduction in the rated capacity of the crane. This reduction, also called a deduct, is specified in the capacity chart. The MG424 has the ability to store this data and to make the deduct from the chart.

This reduction is applied by use of the DEDUCT controls as follows.

Start the selection by pressing the STOWED push button. The display will change to show the current selection in the center display. Use the UP or DOWN arrow to scroll through the selection menu. When at the required Deduct, press the SELECT push button to complete the selection of the new Deduct and return to the normal working screen. In order to remind the operator that a DEDUCT is applied, a lamp is illuminated in the deduct information panel, which is below the Stowed push button. To view the current selection, when indicated by the illuminated lamp, press the Stowed push button. After confirming or changing the selection, press the SELECT push button to complete the selection and return to the normal working screen.

ALTERNATE DISPLAYS

The primary position displays are those of RADIUS and ANGLE. There are alternate displays of HEIGHT and LENGTH available for display but these are only displayed during the time that the alternate display push buttons are pressed. Height alternates with Radius, and Length alternates with Angle.

HEIGHT DISPLAY

Height Display is a push button, used to select the alternate display of Height. Height is displayed only when the push button is pressed and held. When the push button is not pressed, the display always indicates Radius.

LENGTH DISPLAY

Length Display is a push button used to select the alternate display of Length. Length is displayed only when the push button is pressed and held. When this push button is not pressed, the display always indicates the Angle of the main boom.

CONFIGURATION SELECTION (Link-Belt Model 70 shown)

START THE SELECTION OF CRANE CONFIGURATION BY PRESSING "CRANE SET UP"

CRANE SET UP				
SCROLL TO CARRIER				
↑ OR ↓	OUTRIGGERS FULLY EXT.	ON TIRES STATIONARY	PICK AND CARRY	RIGGING TRAVEL
SELECT				

SCROLL TO COUNTERWEIGHT		
↑ OR ↓	COUNTERWEIGHT ATTACHED	COUNTERWEIGHT REMOVED
SELECT		

SCROLL TO BOOM		
↑ OR ↓	MAIN BOOM	MAIN BOOM + MANUAL
SELECT		

SCROLL TO AUX. HEAD		
↑ OR ↓	AUX. HEAD FITTED	AUX. HEAD NOT FITTED
SELECT		

SCROLL TO ATTACHMENT								
↑ OR ↓	NO ATTACHMENT	+35' OFFSET FLY 2°	+35' OFFSET FLY 15°	+35' OFFSET FLY 30°	+35' TELE FLY 2°	+35' TELE FLY 15°	+35' TELE FLY 30°	
		+48' TELE FLY 2°	+48' TELE FLY 15°	+48' TELE FLY 30°	+61' TELE FLY 2°	+61' TELE FLY 15°	+61' TELE FLY 30°	
		+45' TUBE JIB 5°	+45' TUBE JIB 17.5°	+45' TUBE JIB 30°	+45' TUBE JIB 45°	+60' TUBE JIB 5°	+60' TUBE JIB 17.5°	
		+60' TUBE JIB 30°	+60' TUBE JIB 45°	+75' TUBE JIB 5°	+75' TUBE JIB 17.5°	+75' TUBE JIB 30°	+75' TUBE JIB 45°	
SELECT								

SCROLL TO FRONT WINCH LIFTING POINT								
↑ OR ↓	NO ATTACHMENT	+35' OFFSET FLY 2°	+35' OFFSET FLY 15°	+35' OFFSET FLY 30°	+35' TELE FLY 2°	+35' TELE FLY 15°	+35' TELE FLY 30°	
		+48' TELE FLY 2°	+48' TELE FLY 15°	+48' TELE FLY 30°	+61' TELE FLY 2°	+61' TELE FLY 15°	+61' TELE FLY 30°	
		+45' TUBE JIB 5°	+45' TUBE JIB 17.5°	+45' TUBE JIB 30°	+45' TUBE JIB 45°	+60' TUBE JIB 5°	+60' TUBE JIB 17.5°	
		+60' TUBE JIB 30°	+60' TUBE JIB 45°	+75' TUBE JIB 5°	+75' TUBE JIB 17.5°	+75' TUBE JIB 30°	+75' TUBE JIB 45°	
SELECT								

(CONTINUED ON NEXT PAGE)

SCROLL TO REAR WINCH LIFTING POINT							
↑ OR ↓	NO ATTACHMENT	+35' OFFSET FLY 2°	+35' OFFSET FLY 15°	+35' OFFSET FLY 30°	+35' TELE FLY 2°	+35' TELE FLY 15°	+35' TELE FLY 30°
		+48' TELE FLY 2°	+48' TELE FLY 15°	+48' TELE FLY 30°	+61' TELE FLY 2°	+61' TELE FLY 15°	+61' TELE FLY 30°
		+45' TUBE JIB 5°	+45' TUBE JIB 17.5°	+45' TUBE JIB 30°	+45' TUBE JIB 45°	+60' TUBE JIB 5°	+60' TUBE JIB 17.5°
		+60' TUBE JIB 30°	+60' TUBE JIB 45°	+75' TUBE JIB 5°	+75' TUBE JIB 17.5°	+75' TUBE JIB 30°	+75' TUBE JIB 45°
SELECT							

FOLLOWING THE SELECTION OF CRANE SET UP, USE THE WINCH PUSH BUTTON TO SELECT THE LIFTING POINT. SET THE PARTS OF LINE IN USE FOR EACH WINCH USING THE PARTS OF LINE PUSH BUTTON.

CRANE SET-UP EXAMPLES

MAIN BOOM

- ◆ FULLY EXTENDED OUTRIGGERS
- ◆ COUNTERWEIGHT ATTACHED
- ◆ PICKING FROM THE MAIN BOOM WITH THE FRONT WINCH, 6 PARTS OF LINE
- ◆ PICKING FROM THE AUXILIARY HEAD WITH THE REAR WINCH, 1 PART OF LINE
- ◆ THE 35-61' TELE FLY IS STOWED ON THE BOOM

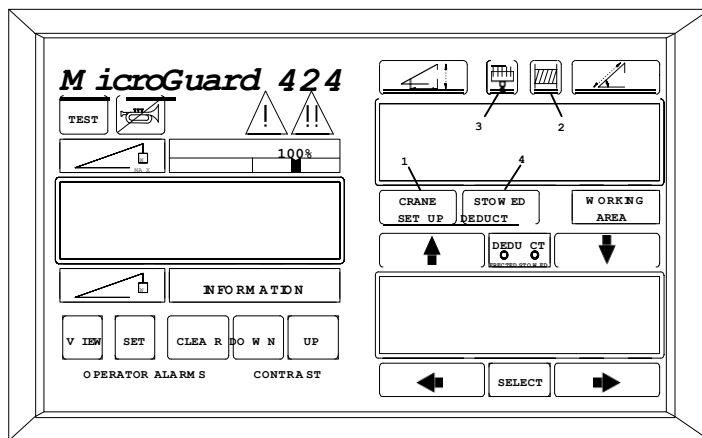

START THE SELECTION BY PRESSING THE **CRANE SET UP** BUTTON (ITEM 1)

SELECT "FULLY EXTENDED OUTRIGGERS"

SELECT "COUNTERWEIGHT ATTACHED"

SELECT "MAIN BOOM"

SELECT "AUX. HEAD" FITTED

SELECT "NO ATTACHMENT"

SELECT LIFTING POINT FOR FRONT

WINCH, "MAIN BOOM"

SELECT LIFTING POINT FOR REAR WINCH, "AUXILIARY HEAD"

PRESS **WINCH SELECT** (ITEM 2) TO SELECT FRONT WINCH "F"

PRESS **PARTS OF LINE** (ITEM 3) TO SELECT 6 PARTS OF LINE

PRESS **WINCH SELECT** (ITEM 2) TO SELECT REAR WINCH "R"

PRESS **PARTS OF LINE** (ITEM 3) TO SELECT 1 PART OF LINE

PRESS **STOWED DEDUCT** (ITEM 4) TO SELECT 35-61' TELE FLY

THE SYSTEM IS NOW SET UP, AS DESCRIBED ABOVE, AND THE ONLY SELECTION TO BE MADE IS FRONT OR REAR WINCH FOR THE LIFTING POINT. THE LOAD AND RADIUS WILL BE FOR THE SELECTED LIFTING POINT.

CRANE SET-UP EXAMPLES

MAIN BOOM PLUS 35' OFFSETTABLE FLY

- ◆ FULLY EXTENDED OUTRIGGERS
- ◆ COUNTERWEIGHT REMOVED
- ◆ MAIN BOOM + MANUAL, THE AUXILIARY HEAD IS FITTED BUT IS NOT BEING USED
- ◆ PICKING FROM THE MAIN BOOM + MANUAL WITH THE FRONT WINCH, 6 PARTS OF LINE
- ◆ PICKING FROM THE 35' OFFSETTABLE FLY AT 15° OFFSET WITH THE REAR WINCH, 1 PART OF LINE
- ◆ NO STOWED ATTACHMENTS ON THE BOOM

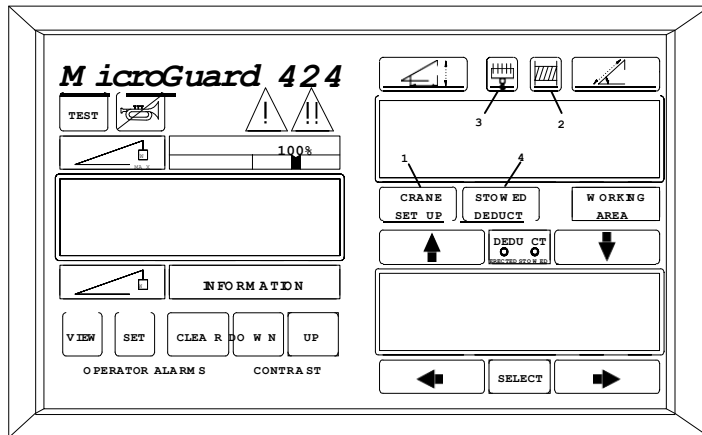

START THE SELECTION BY PRESSING THE **CRANE SET UP** BUTTON (ITEM 1)

SELECT "FULLY EXTENDED OUTRIGGERS"

SELECT "COUNTERWEIGHT REMOVED"

SELECT "MAIN BOOM + MANUAL"

SELECT "AUX. HEAD" FITTED

SELECT "35' OFFSET FLY, 15° OFFSET"

SELECT LIFTING POINT FOR FRONT WINCH, "MAIN BOOM + MANUAL"

SELECT LIFTING POINT FOR REAR WINCH, "35' OFFSET FLY, 15° OFFSET"

PRESS **WINCH SELECT** (ITEM 2) TO SELECT FRONT WINCH "F"

PRESS **PARTS OF LINE** (ITEM 3) TO SELECT 6 PARTS OF LINE

PRESS **WINCH SELECT** (ITEM 2) TO SELECT REAR WINCH "R"

PRESS **PARTS OF LINE** (ITEM 3) TO SELECT 1 PART OF LINE

THE SYSTEM IS NOW SET UP, AS DESCRIBED ABOVE, AND THE ONLY SELECTION TO BE MADE IS FRONT OR REAR WINCH FOR THE LIFTING POINT. THE LOAD AND RADIUS WILL BE FOR THE SELECTED LIFTING POINT.

CRANE SET-UP EXAMPLES

MAIN BOOM PLUS 48' TELESCOPING FLY

- ◆ FULLY EXTENDED OUTRIGGERS
- ◆ COUNTERWEIGHT ATTACHED
- ◆ MAIN BOOM, THE AUX. HEAD IS NOT FITTED
- ◆ PICKING FROM THE MAIN BOOM WITH THE FRONT WINCH, 4 PARTS OF LINE
- ◆ PICKING FROM THE 48' TELESCOPING FLY AT 30° WITH THE REAR WINCH, 1 PART OF LINE
- ◆ NO STOWED ATTACHMENTS ON THE BOOM

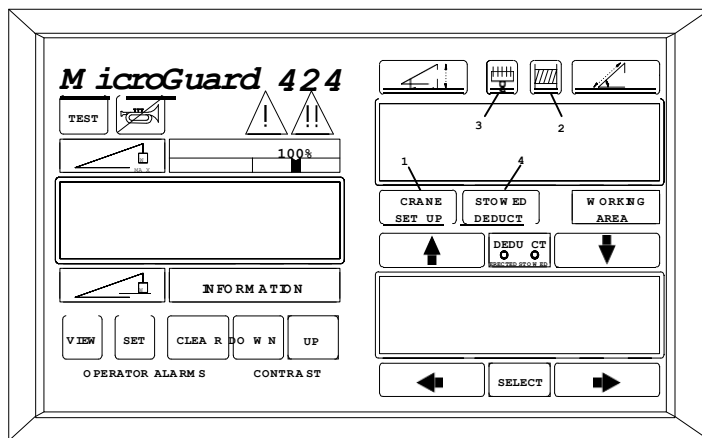

START THE SELECTION BY PRESSING THE **CRANE SET UP** BUTTON (ITEM 1)

SELECT "FULLY EXTENDED OUTRIGGERS"

SELECT "COUNTERWEIGHT ATTACHED"

SELECT "MAIN BOOM"

SELECT "AUX. HEAD"
NOT-FITTED

SELECT "48' TELE FLY, 30° OFFSET"

SELECT LIFTING POINT FOR FRONT WINCH, "MAIN BOOM"

SELECT LIFTING POINT FOR REAR WINCH, "48' TELE FLY, 30° OFFSET"

PRESS **WINCH SELECT** (ITEM 2) TO SELECT FRONT WINCH "F"

PRESS **PARTS OF LINE** (ITEM 3) TO SELECT
4 PARTS OF LINE

PRESS **WINCH SELECT** (ITEM 2) TO SELECT
REAR WINCH "R"

PRESS **PARTS OF LINE** (ITEM 3) TO SELECT
1 PART OF LINE

THE SYSTEM IS NOW SET UP, AS DESCRIBED ABOVE, AND THE ONLY SELECTION TO BE MADE IS FRONT OR REAR WINCH FOR THE LIFTING POINT. THE LOAD AND RADIUS WILL BE FOR THE SELECTED LIFTING POINT.

CRANE SET-UP EXAMPLES

ON TIRES

- ◆ PICK AND CARRY CENTERED OVER REAR
- ◆ COUNTERWEIGHT REMOVED
- ◆ MAIN BOOM
- ◆ PICKING FROM THE MAIN BOOM WITH THE FRONT WINCH, 4 PARTS OF LINE
- ◆ THE AUXILIARY HEAD IS FITTED BUT IS NOT USED ON TIRES (LBCE NOTE 22)
- ◆ THE 35-61' TELE FLY IS STOWED ON THE BOOM

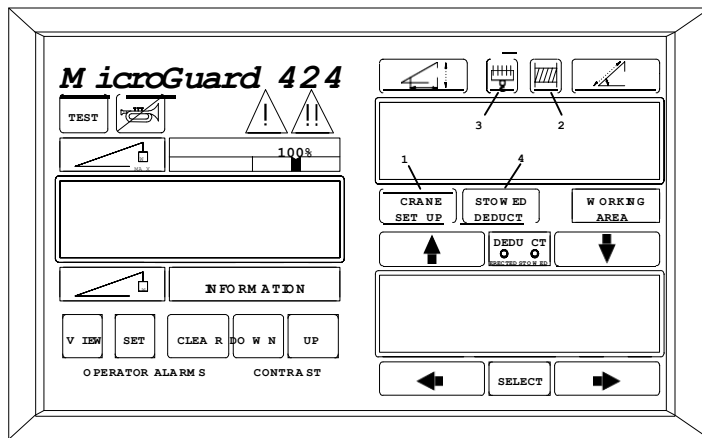

START THE SELECTION BY PRESSING THE **CRANE SET UP** BUTTON (ITEM 1)

SELECT "PICK AND CARRY, CENTERED REAR"

SELECT "COUNTERWEIGHT REMOVED"

SELECT "MAIN BOOM"

SELECT "AUX. HEAD" FITTED

SELECT "NO ATTACHMENT"

SELECT LIFTING POINT FOR FRONT WINCH, "MAIN BOOM"

SELECT LIFTING POINT FOR REAR WINCH, "AUXILIARY HEAD"

PRESS **WINCH SELECT** (ITEM 2) TO SELECT FRONT WINCH "F"

PRESS **PARTS OF LINE** (ITEM 3) TO SELECT 4 PARTS OF LINE

PRESS **WINCH SELECT** (ITEM 2) TO SELECT REAR WINCH "R"

PRESS **PARTS OF LINE** (ITEM 3) TO SELECT 1 PART OF LINE

PRESS **STOWED DEDUCT** (ITEM 4) TO SELECT 35-61' TELE FLY

THE SYSTEM IS NOW SET UP, AS DESCRIBED ABOVE, AND THE ONLY SELECTION TO BE MADE IS FRONT WINCH FOR THE LIFTING POINT. THE LOAD AND RADIUS WILL BE FOR THE SELECTED LIFTING POINT.

CRANE SET-UP EXAMPLES

RIGGING/TRAVEL MODE

The Rigging /Travel mode is selected as part of the carrier options. This mode is used to facilitate the rigging and travel of the crane by inhibiting motion-cut and audible alarm while selected. The information screen is restricted to the display of radius, length, angle, height and precautionary messages during the time that the mode is selected.

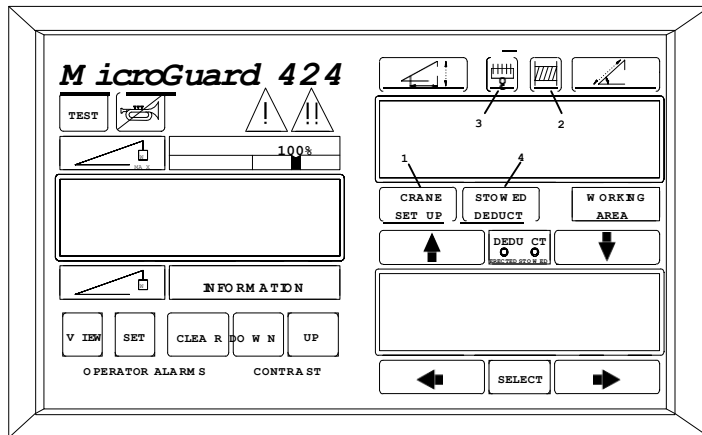

START THE SELECTION BY PRESSING THE **CRANE SET UP** BUTTON (ITEM 1)

SELECT "RIGGING/TRAVEL MODE"

THE LOWER RIGHT DISPLAY WILL READ:

Rigging/Travel Mode

THE LEFT DISPLAY WILL READ:

To Resume, press
CRANE SETUP

CAUTION!

THE RIGGING TRAVEL MODE INHIBITS ALL MOTION CUT AND AUDIBLE ALARMS FOR ALL ALARM CONDITIONS. IT IS TO BE USED ONLY FOR THE RIGGING OR TRAVEL OF THE MACHINE DURING WHICH TIME ALARMS AND MOTION CUT ARE NOT REQUIRED.

BEFORE RESUMING ANY LIFTING OPERATIONS SELECT THE APPROPRIATE CONFIGURATION BY PRESSING **CRANE SETUP**.

THE SYSTEM IS NOW SET UP, AS DESCRIBED ABOVE. RADIUS, ANGLE, AND ALTERNATES LENGTH AND HEIGHT WILL DISPLAYED IN THE RIGGING /TRAVEL MODE BUT LOAD INFORMATION IS NOT DISPLAYED.

OPERATOR SETTABLE ALARMS

An additional feature of the MicroGuard® 424 System is the provision of Operator Settable Alarms. These alarms, when properly set by the operator, provide a method of obstacle avoidance. This is achieved by means of minimum and maximum angle, maximum length and maximum height alarms. These alarms can be programmed for each job site and set rapidly for the prevailing site conditions, thereby aiding the operator in the safe operation of the crane.

Most alarms will occur automatically as a result of limitations imposed by the capacity chart. The operator has control over additional alarms, which are set to define the working range of the machine for particular site requirements, and which will provide a measure of obstacle avoidance.

Four alarms are available for operator use.

The diagram shows the operator control panel for the MicroGuard 424 system. The panel includes the following elements:

- Display Area:** Shows "MicroGuard 424" at the top left. Below it are icons for TEST, a crane hook, and two warning triangles (one with a single exclamation mark, one with two). A progress bar is set to 100%.
- Alarm Settings:**
 - MIN ANGLE: 31.5
 - MAX ANGLE: 75.4
 - MAX LENGTH: 92.0
 - MAX HEIGHT: 98.5
- Control Buttons:**
 - CRANE SET-UP, STOW ED DEDUCT, W ORKNG AREA
 - Up arrow, DEDUCT (with up/down arrows), Down arrow
 - VIEW, SET, CLEAR, DOW N, UP
 - Left arrow, SELECT, Right arrow
- Information:** A button labeled "NFORMATION" is located below the angle settings.
- Labels:** At the bottom, "OPERATOR ALARM S" and "CONTRAST" are visible.

Labels on the right side of the diagram identify the four alarms: MINIMUM ANGLE, MAXIMUM ANGLE, MAXIMUM LENGTH, and MAXIMUM HEIGHT.

METHOD OF SETTING

WARNING

THE FOLLOWING EXAMPLES ARE GIVEN TO ILLUSTRATE METHODS OF SETTING ALARMS. THE ACTUAL VALUES GIVEN SHOULD NOT BE USED WITHOUT FIRST CHECKING THE CAPACITY CHART TO ENSURE SAFE, STABLE OPERATION UNDER THE CONDITIONS DESCRIBED.

NOTE

OPERATOR ALARMS WILL BE STORED IN THE COMPUTER MEMORY, EVEN IF THE CRANE IS SHUTDOWN. THE FOLLOWING PROCEDURES WILL DESCRIBE THE METHOD OF SETTING OR CANCELING ALARMS.

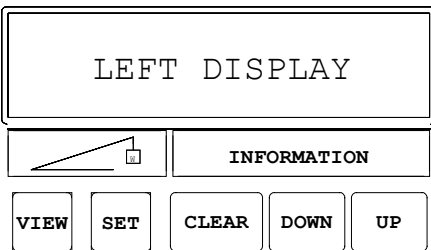

Alarms can only be SET or CLEARED from within the alarm screen. From the main working screen, press **VIEW** to access the Operator Alarm screen. The cursor is an arrow that points to the alarm, which may be set or cleared and is always at the first position when entering the alarm screen. It may be moved to any position on the alarm screen by use of the **UP/DOWN** arrows.

When the cursor is pointing to an alarm, the numerical value

displayed will be the current position of the crane except when that alarm has previously been SET. In this case, the SET value will be indicated and will alternate with the word, "SET." Alarms which are set but to which the cursor is not pointing indicate the previously set value. Other alarms, which are NOT SET, are indicated by the word, "OFF."

The functions of the push buttons when in the alarm screen are:

- ◆ **VIEW** Used to access the alarm screen in order to view the currently set alarms.
- ◆ **SET** Used to SET the alarm value. The alarm value is determined by the position of the crane at the time the SET button is pressed.
- ◆ **CLEAR** Used to clear a previously SET alarm. Alarms can only be CLEARED when the cursor is pointing to the item to be cleared. Use the UP/DOWN arrows to move the cursor to the desired alarm. Press CLEAR to cancel that alarm.
- ◆ **UP/DOWN ARROWS** Used to move the cursor up or down the screen to the alarm that is to be viewed, SET or CLEARED.
- ◆ **SELECT** Used to return to the normal operating screen.

EXAMPLES OF SETTING THE ALARMS

Setting the alarm point is achieved by positioning the crane at the point at which the alarm is to sound and then, when in the operator alarm screen, using the SET push button to set the alarm. The following examples illustrate the use of the procedures.

EXAMPLE A

To have an alarm whenever the boom is below a 30° angle, use the following procedure:

1. Press **VIEW** to access the alarm screen. The cursor will be at MIN. ANGLE.
2. Move the boom to 30° angle.
3. Press **SET** to enter the alarm. The displayed value will be the alarm setting, and it will alternate with the word SET.
4. When the alarm is set, press **SELECT** to return to the working screen. The red lamp and the audible alarm will operate whenever the boom is below 30°. The message MIN. ANGLE will appear in the INFORMATION area on the left display.

EXAMPLE B

To have an alarm whenever the boom is above 60° angle, use the following procedure:

1. Press **VIEW** to access the alarm screen. The cursor will be at MIN. ANGLE. Press the DOWN ARROW to move the cursor to MAX. ANGLE.
2. Move the boom to 60° angle.
3. Press **SET** to enter the alarm. The displayed value will be the alarm setting and it will alternate with the word SET. Press **SELECT** to return to the working screen. The red lamp and the audible alarm will operate whenever the boom is above 30°. The message MIN. ANGLE will appear in the INFORMATION area on the left display.

EXAMPLE C

To have an alarm whenever the boom length exceeds 50 feet, use the following procedure:

1. Press **VIEW** to access the alarm screen. The cursor will be at MIN. ANGLE. Press the DOWN ARROW to move the cursor to MAX. LENGTH.
2. Extend the boom to 50 feet.
3. Press **SET** to enter the alarm. The displayed value will be the alarm setting and it will alternate with the word SET. Press **SELECT** to return to the working screen. The red lamp and the audible alarm will operate whenever the boom is extended beyond 50 feet. The message, MAX. LENGTH will appear in the INFORMATION area on the left display.

EXAMPLE D

To have an alarm whenever the boom tip height exceeds 75 feet, use the following procedure:

1. Extend the boom and/or adjust the boom angle so that the tip height is 75 feet.
2. Press **VIEW** to access the alarm screen. The cursor will be at MIN. ANGLE. Press the DOWN ARROW to move the cursor to MAX. HEIGHT.
3. Press **SET** to enter the alarm. The displayed value will be the alarm setting and it will alternate with the word SET. Press **SELECT** to return to the working screen. The red lamp and the audible alarm will operate whenever the boom tip height exceeds 75 feet. The message MAX. HEIGHT will appear in the INFORMATION area on the left display.

CANCELING ALARMS

CLEAR is used to cancel a previously SET alarm. Alarms can only be CLEARED when the cursor is pointing to the item to be cleared. Canceling of alarms can be carried out regardless of the position of the crane.

1. Press **VIEW** to access the alarm screen.
2. Move the cursor to point to the alarm to be canceled.
3. Press **CLEAR** to cancel the alarm. The displayed value will be the current position of the crane and the word SET will no longer be displayed.
4. Move the cursor to point to the next alarm to be canceled.
5. When all the chosen alarms are canceled, press **SELECT** to return to the working screen.

PERIODIC INSPECTIONS

CHECKING THE ANTI TWO BLOCK SYSTEM

MAIN SWITCH

1. Lower the boom so that the A.T.B. switches can be reached by hand.
2. Set the Selector Switch located on the Main Switch housing to the "Main" position and check that raising the weight to trip the switch causes the A.T.B. alarm to operate.

JIB SWITCHES

If the crane is equipped with additional Jib switches, check as follows.

1. Connect the cable from the Jib switch to the receptacle on the Main Switch.
2. Set the Selector Switch to "Both".
3. Check that raising the weight and tripping the switch on EITHER the Main OR the Jib switch causes the A.T.B. alarm to operate.
4. Set the Selector Switch to "Jib".
5. Check that raising the weight on the Jib switch only and tripping the switch causes the A.T.B. alarm to operate.

FUNCTION KICK-OUT

If the crane is equipped with Function Kick-Out, check the operation of the system as follows:

1. With the crane in any normal working configuration, raise the hook block sufficiently to cause the A.T.B. switch to operate.
2. Check that when the audible alarm sounds the following functions are stopped:
 - ◆ Main Winch Up
 - ◆ Aux. Winch Up
 - ◆ Boom Hoist Lower
 - ◆ Telescope Out (all cylinders)
3. Check that when the CANCEL ALARM by-pass system is enabled or the RIGGING/TRAVEL MODE is selected, the audible alarm is silenced and the motions are restored.

CAUTION

WHEN CARRYING OUT THIS TEST THE FUNCTION KICK-OUT CIRCUITS DO NOT PROTECT THE CRANE. TAKE CARE THAT THE CRANE IS NOT PUT INTO AN ACTUAL TWO-BLOCK CONDITION INADVERTENTLY.

DO NOT OPERATE THE CRANE UNDER THE ABOVE CONDITIONS.

SYSTEM CHECKS

- ◆ Check that the displayed boom angle agrees with the measured angle.
- ◆ Check that the displayed radius agrees with the measured operating radius.
- ◆ Check that the displayed boom length agrees with the actual boom length.
- ◆ If a known test weight is available, check that the displayed weight agrees with the test load. *The displayed load includes the hook block and any lifting attachments such as slings, pins and shackles.*
- ◆ If the capacity chart is rated for specific areas e.g., side, front or rear, the system should be checked by swinging the boom into the permitted areas and checking that the Rated Capacity reading agrees with the crane Capacity Chart.

ROUTINE MAINTENANCE

The MicroGuard® 424 System has built-in self-test facilities and checks itself each time the system is switched on. Only a minimum level of preventive maintenance is required. This is restricted to visual inspections of cables and sensors for obvious signs of wear and tear and inspection of mechanical parts, such as extension reels and anti two-block switches.

MICROGUARD® 424 OPERATION/TROUBLESHOOTING MANUAL

TABLE OF CONTENTS

SECTION 2: TROUBLESHOOTING

FAULT DIAGNOSTIC PROCEDURES	29
GROUP "A" FAULT CODES	30-31
POWER SUPPLY VOLTAGES.....	32
INPUT POWER	32
INTERNAL POWER SUPPLIES.....	32
ACCESSING THE COMPUTER AND TERMINATION BOARDS	33
CHECKING ANALOG DRIVE VOLTAGE	33
PRESSURE CHANNEL FAULT GUIDE.....	34-36
FUNCTIONAL TESTS.	34
TRANSDUCER RESISTANCE MEASUREMENT.....	35
PISTON PRESSURE TRANSDUCER	35
ROD PRESSURE TRANSDUCER.....	35-36
ANALOG DRIVE VOLTAGE.....	36
BOOM EXTENSION SENSOR AIN2.....	37
BOOM ANGLE SENSOR AIN3	38
SWING POTENTIOMETER AIN5 AND AIN6	39
NO DUTY FOUND.....	40
OTHER SYSTEM FAULTS	40
EXECUTIVE ROM.....	40
PERSONALITY ROM.....	40
SCRATCHPAD RAM.....	40
DUTY ROM.....	40
CURRENT DUTY BAD.....	40
CONFIGURATION UNCALIBRATED.....	40
DIGITAL I/O AND ANALOG I/O	40
DISPLAY UNIT.....	40
ANTI TWO-BLOCK SYSTEM.....	41
ANTI TWO-BLOCK LOGIC LEVELS	42

PARTS REPLACEMENT.....	43-45
PRESSURE TRANSDUCERS	43
EXTENSION REEL.....	43
BOOM ANGLE SENSOR HTC8660 ONLY.....	43
BOOM ANGLE SENSOR.....	44
EXECUTIVE ROM CHIP.....	44
PERSONALITY ROM CHIP	44
DUTY ROM CHIP	44
COMPUTER BOARD	44
COMPUTER BOX	45
CHIP REMOVAL AND INSTALLATION.....	45
GLOSSARY	46-48
COMPUTER BOARD LAYOUT	49
TERMINATION BOARD LAYOUT	50
EXTENSION REEL LAYOUT	51

TROUBLESHOOTING

FAULT DIAGNOSTIC PROCEDURES

Faults in the MicroGuard® 424 System are detected automatically. Each time the MicroGuard® 424 System is switched on it goes through a start up self-test which lasts about 2-3 seconds. During normal operation a self-test can be initiated by pressing the TEST button on the display.

Fault conditions in external sensors are detected without the need for a system self-test.

Faults detected in the MicroGuard® 424 System during self-test are indicated on the display as follows:

- The word FAULT will appear in the information area of the left display.
- The RED LAMP will illuminate and the AUDIBLE ALARM will sound.

When faults occur in the system they can be diagnosed using the display.

Details of the fault locations are obtained by pressing and holding the test button. Holding the test button will cause the system to go through a self-test during which faults will be detected.

Following completion of the self-test:

If the test button continues to be pressed, the fault screen will appear. The fault screen will remain visible for as long as the test button is pressed. Information will be displayed on the screen in four groups.

- Group A Sensor faults
- Group B I/O faults
- Group C Memory faults
- Group D General faults

FAULT CODES

GROUP "A" ANALOG SENSORS

CODE

AAA		
000		NO FAULTS
001	AIN0	PISTON PRESSURE TRANSDUCER
002	AIN1	ROD PRESSURE TRANSDUCER
004	AIN2	EXTENSION SENSOR
008	AIN3	BOOM ANGLE SENSOR
016	AIN4	S' STRUCTURE ANGLE SENSOR
032	AIN5	SWING POTENTIOMETER "A"
064	AIN6	SWING POTENTIOMETER "B"

GROUP "B" INPUTS AND OUTPUTS

CODE

BB		FAULT
00		NO FAULTS
01	1	DIGITAL INPUT AND OUTPUT
02	2	ANALOG INPUT AND OUTPUT
04	4	DISPLAY UNIT

GROUP "C" MEMORY

CODE

CC		
00		NO FAULTS
01	1	EXECUTIVE ROM
02	2	DUTY ROM
04	4	SCRATCHPAD RAM
08	8	PERSONALITY ROM

GROUP "D" GENERAL

CODE

DD		
00		NO FAULTS
01	1	NO DUTY FOUND
02	2	CURRENT DUTY BAD
04	4	CONFIGURATION UNCALIBRATED
08	8	2 HZ OSCILLATOR

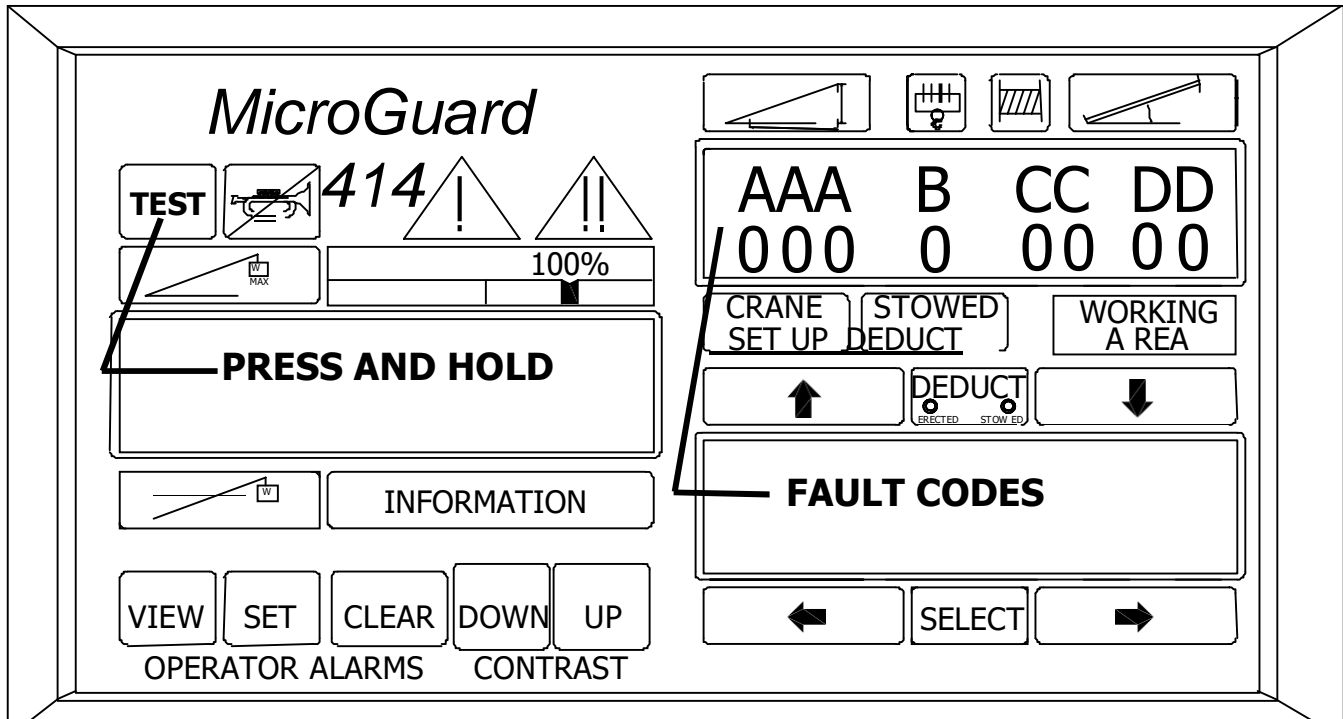

GROUP 'A' FAULT CODES

If a fault is detected by the system, a number will appear under one or more of the four group headings A through D. This number will correspond to one or more fault diagnostic numbers. The meaning of these numbers can be determined by looking at the appropriate code in the fault interpretation table.

Group A fault codes relate to analog sensors. Each sensor is allocated a number and this number is also the number of the channel to which it is connected in the system.

- Sensor 0 Piston Pressure
- Sensor 1 Rod Pressure
- Sensor 2 Extension Sensor
- Sensor 3 Boom Angle
- Sensor 4 Superstructure Angle
- Sensor 5 Swing Potentiometer "A"
- Sensor 6 Swing Potentiometer "B"

Each sensor is allocated a FAULT CODE and this is the number that appears under the group heading in the fault code display.

- | | | |
|------------|----------|------------------|
| 001 | Sensor 0 | Piston Pressure |
| 002 | Sensor 1 | Rod Pressure |
| 004 | Sensor 2 | Extension Sensor |
| 008 | Sensor 3 | Boom Angle |

- | | | |
|------------|----------|-------------------|
| 016 | Sensor 4 | S'structure Angle |
| 032 | Sensor 5 | Swing Pot'r "A" |
| 064 | Sensor 6 | Swing Pot'r "B" |

When there are no faults detected in the system, '000' will appear under all group headings indicating that there are no detected faults in the system. When there are faults in only one sensor, the code will be one of the codes listed above. When there are faults in more than one sensor, the codes indicated will be the sum of the fault codes.

EXAMPLES OF FAULT CODES

Fault 0

AAAB	CC DD
000 0	00 00
No faults detected.	

Fault 1

AAAB	CC DD
001 0	00 00
Piston pressure transducer.	

Fault 2

AAAB	CC DD
002 0	00 00
Rod pressure transducer	

Fault 3

AAAB CC DD
 003 0 00 00
 Piston pressure transducer
 Rod pressure transducer

Fault 4

AAAB CC DD
 004 0 00 00
 Extension Sensor

Fault 5

AAAB CC DD
 005 0 00 00
 Piston pressure transducer
 Extension sensor

Fault 6

AAAB CC DD
 006 0 00 00
 Rod pressure transducer
 Extension sensor
 Rod pressure transducer

Fault 7

AAAB CC DD
 007 0 00 00
 Piston pressure transducer
 Rod pressure transducer
 Extension sensor

Fault 8

AAAB CC DD
 008 0 00 00
 Boom angle sensor

Fault 9

AAAB CC DD
 009 0 00 00
 Piston pressure transducer
 Boom angle sensor

Fault 10

AAAB CC DD
 010 0 00 00
 Boom angle sensor
 Rod pressure transducer

Fault 11

AAAB CC DD
 009 0 00 00
 Boom angle sensor
 Piston pressure transducer
 Rod pressure transducer

Fault 32

AAAB CC DD
 032 0 00 00
 Swing potentiometer "A"

Fault 64

AAAB CC DD
 064 0 00 00
 Swing potentiometer "B"

Fault 96

AAAB CC DD
 096 0 00 00
 Swing potentiometer "A"
 Swing potentiometer "B"

This sequence continues up to the maximum fault code of **127** that is the sum of all group "A" fault codes.

Fault 127

AAAB CC DD
 127 0 00 00
 All analog sensors.

This fault condition is seldom caused by the simultaneous failure of all sensors. It is more usually the result of the failure of the analog drive voltage, which is the supply voltage for all sensors. This power supply fault may be due to the failure of the power supply or may be due to damage to the cable that connects the sensor to the computer.

When this fault occurs, carry out Power Supply Voltage checks before checking individual sensors.

POWER SUPPLY VOLTAGES

The Computer Unit contains 2 major boards, the Terminal Connection Board and the Computer Board. Both of these assemblies are located in an aluminum box that is usually located on the rear wall of the cab or can be inside or outside the cab depending on crane model. All of the cables from the various sensors and the display are connected to the Terminal Connection Board. To gain access to the Terminal Connection Board, refer to [Page 33](#) of this manual.

INPUT POWER

The computer operates from an input voltage in the range **11 to 36 volts DC**. This input voltage is measured across the B+ and B- terminals on the Terminal Connection Board and corresponds to the battery voltage of the crane. At voltages below 10.5 and above 38 volts the system will power down until correct voltage is restored.

If the INPUT POWER is not within these limits, check the battery and/or alternator before servicing the computer.

INTERNAL POWER SUPPLIES

The computer generates its own internal power from the incoming battery voltage.

This power can be monitored at the test points inside the computer adjacent to the fuses and Battery Input Terminals.

To monitor the Internal Power Supplies, use a Digital Voltmeter set to the appropriate DC voltage range.

Connect the black (-ve) lead to GND

Connect the red (+ve) lead in turn to

+15V +/- 0.1

-15V +/- 0.1

+5V +/- 0.1

If the voltages are out of range, it may be necessary to replace the computer.

Before replacing the computer, refer to

Greer Company

Product Support Department

714-259-9702

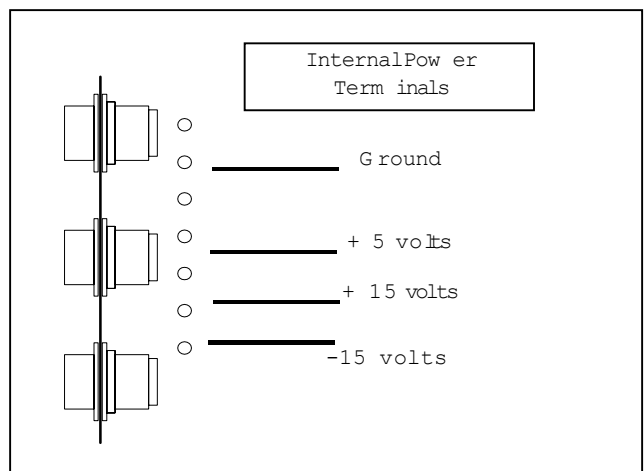
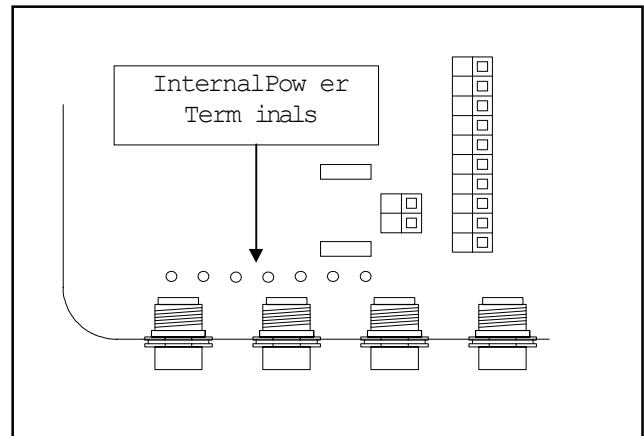
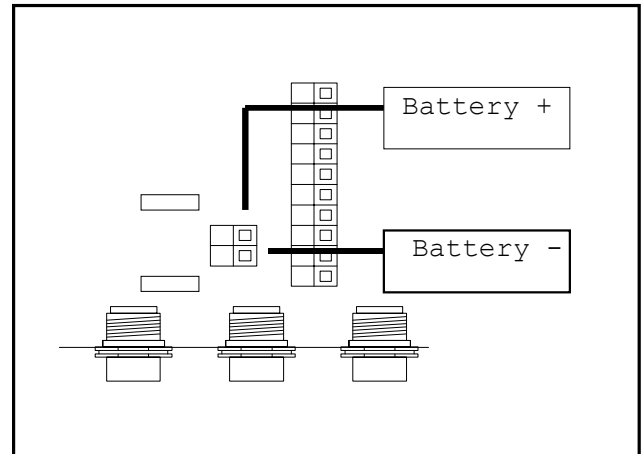

ACCESSING MAIN COMPUTER BOARD AND TERMINATION BOARD

1. Remove the four screws (1) securing the computer lid to the computer box. This lid is NOT hinged. Take care **not** to allow the lid to fall from the box. Set the lid aside.
2. Under the lid you will see the Main Computer Board. This board contains the microprocessor and its related components. This unit is held in place by two screws (2) located at the left and right of the Main Computer Board backing plate and is connected to the Terminal Connection Board via 2 ribbon cables. These cables carry the signals to and from the Termination Board. These will be to the top of the Main Computer Board.
3. If you are going to check voltages on the Termination Board, remove the two screws located at the left and right of the Main Computer Backing Plate and swing the assembly up. Take care not to damage the ribbon cables. These ribbon cables must remain connected to the Main Computer Board for voltage checks.

CHECKING ANALOG DRIVE VOLTAGE

To check the Analog Sensor Drive Voltage, use the following procedure:

1. Access the Termination Board.
2. With the system power on and a digital volt meter set to read DC voltage, place the negative lead on any -DR (- Drive) terminal (1) of the Analog Input Group.
3. Place the positive lead of the meter on any +DR (+ Drive) terminal (2).
4. The voltage should be 5.25+/-0.1volts.
5. If the Analog Drive Voltage is not within this range, disconnect all of the external sensor cables, including pressure transducers, cables 1 through 5.
6. Recheck the Analog Drive Voltage. If the voltage is still out of range, the Computer Board will need to be replaced. If the voltage is within range, reconnect

each cable, one at a time, checking the Analog Drive Voltage after each cable is connected.

- If after reconnecting any one of the sensors the Analog Drive Voltage goes out of range, it is probable that the wiring to the sensor is grounded or the sensor itself is faulty.

Check all wires and the sensor itself and repair or replace as required.

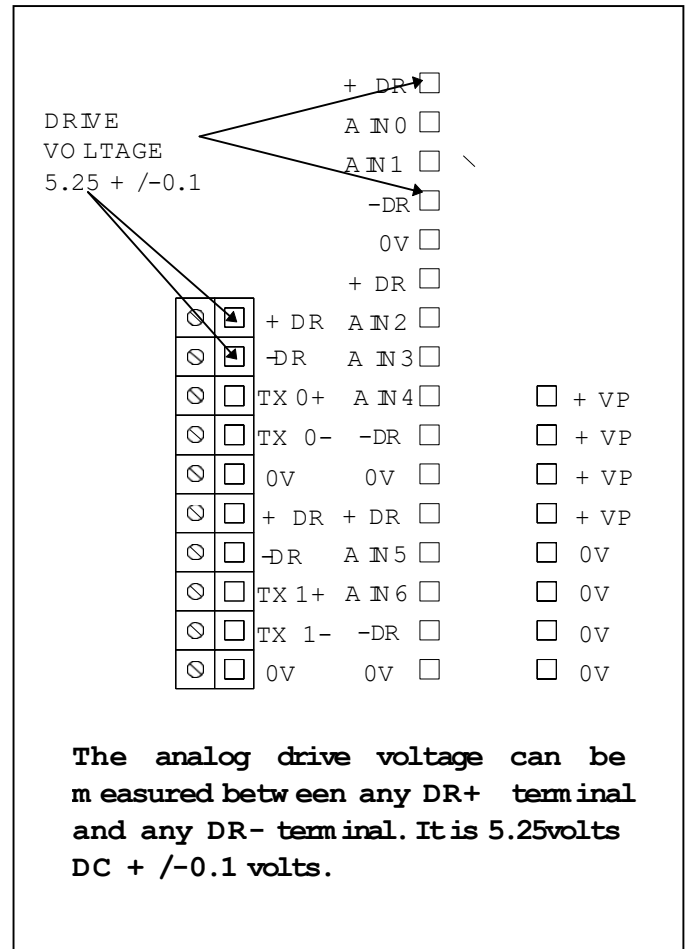
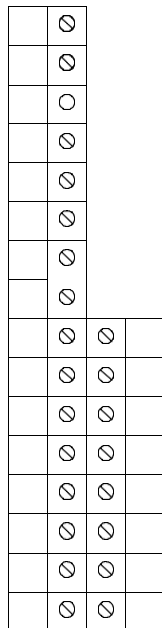

fully retracted, relieve all pressure from both

PRESSURE CHANNEL FAULT GUIDE FUNCTIONAL TESTS

A fault in a pressure transducer is such that a fault on one channel can cause an apparent fault in the other channel. It is necessary to test both channels and both transducers together in order to determine which transducer is at fault.

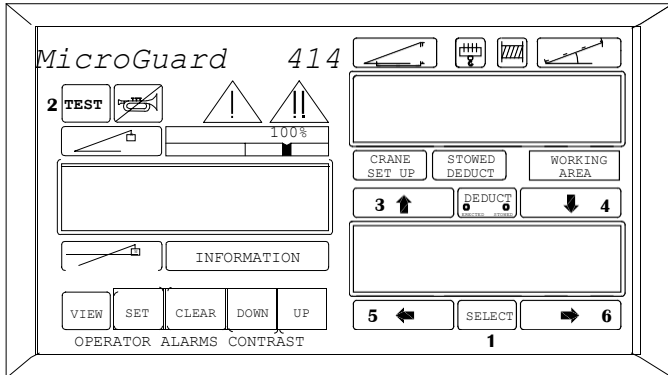

1. Access the calibration routine by simultaneously pressing and holding
SELECT (1) and TEST (2) keys

The display will request entry of the calibration security code.

2. The security code is entered by the consecutive pressing of the calibration arrow keys which MUST be in the following sequence:

Up, (3), Down (4),

Left (5), Right (6),

SELECT (1)

If the wrong sequence is used, or if the entry is not completed within 5 seconds, the calibration entry will be aborted and must be re-entered. After accessing the calibration routine, the system alarm will sound as a reminder that the calibration routine is active.

3. Use the Up (3) or Down (4) Arrow keys to scroll to command 06 Zero. Press Select (1).
4. Press the Left Arrow (5) and then use the Up (3) or Down (4) Arrow keys to select TX 0 (pressure transducer 0 piston side). Press Select (1).
5. With the boom in the rest or the boom hoist cylinder

bridge of the pressure transducers.

transducers. With no pressure, the upper display should indicate 0+/-20 bits.

6. Press the Left Arrow (5) and then use the Up (3) or Down (4) arrow keys to select TX1 (pressure transducer rod side). With no pressure in the cylinder, the upper display should read 0+/- 20 bits.
7. If the transducers were disconnected in step 5, tighten the fittings. With the boom fully retracted, boom up to a 60° angle.
8. Access the Zero of TX 0, as described in step 5. The upper display should read 200+/-100 bits.
9. Access the Zero of TX 1, as described in step 7. The upper display should read 5+/-25 bits.
10. Boom down. As the boom is moving down, the displayed bits of TX 1 should increase.
11. Place the retracted boom at a 60° angle. Access the Zero of TX 0, as described in step 4, and extend the boom. As the boom is extended, the displayed bits of TX 0 should increase. When the boom is fully extended, the display should read 400+/-100 bits for a three-section boom and 600+/-100 bits for a four- section boom.

The values listed are nominal values. The actual values will differ according to how the crane is equipped. A three-section boom will show a smaller value on TX 0 under the same conditions as a four- section boom. Additional equipment on the main boom, such as stowed fly, auxiliary head sheaves and hook blocks will give a higher value than the main boom alone. If any value is out of range, contact your distributor or factory service department before replacing a pressure transducer. Refer to page 43 of this manual for pressure transducer replacement.

12. Exit the calibration routine by pressing the TEST (2) key.

If the foregoing functional tests indicate faults in the pressure channels, proceed with Power Supply Tests and the test of the resistance of the

PRESSURE CHANNEL FAULT GUIDE

TRANSDUCER RESISTANCE MEASUREMENT

The pressure transducer is a balanced bridge composed of strain gauges bonded to a flexible diaphragm. The following resistance tests can be carried out to establish the viability of the pressure transducer.

Piston Pressure Transducer

1. With the power to the computer off, disconnect the piston pressure transducer from connector 1 on the computer.
2. With the DVM set to the Ohms range, measure the resistance between pins "C" and "D" of connector MS3474W14-5PZ.

The resistance should be $350\Omega \pm 10\Omega$

3. With the DVM set to the Ohms range, measure the resistance between pins "B" and "E" of connector MS3474W14-5PZ.

The resistance should be $350\Omega \pm 10\Omega$

4. With the DVM set to the Ohms range, measure the resistance between pins B, C, D, E, and the case of the transducer. Measure the resistance between B, C, D, E and the case of the connector.

There should be no connection between the case and any of the pins.

Rod Pressure Transducer

1. With the power to the computer off, disconnect the rod pressure transducer from connector 2 on the computer.
2. With the DVM set to the Ohms range, measure the resistance between pins "C" and "D" of connector MS3474W14-5PZ.

The resistance should be $350\Omega \pm 10\Omega$

3. With the DVM set to the Ohms range, measure the resistance between pins "B" and "E" of connector MS3474W14-5PZ.

The resistance should be $350\Omega \pm 10\Omega$

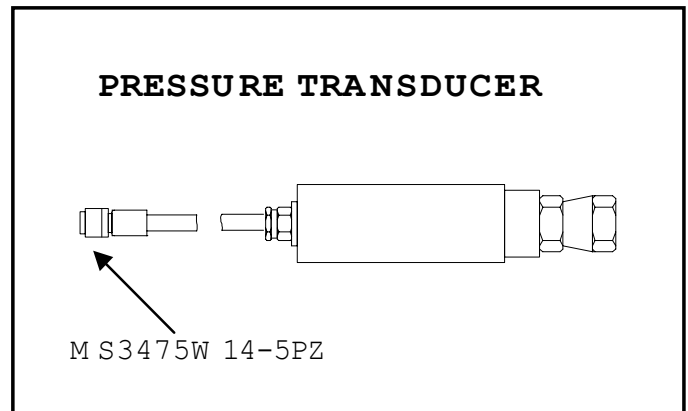
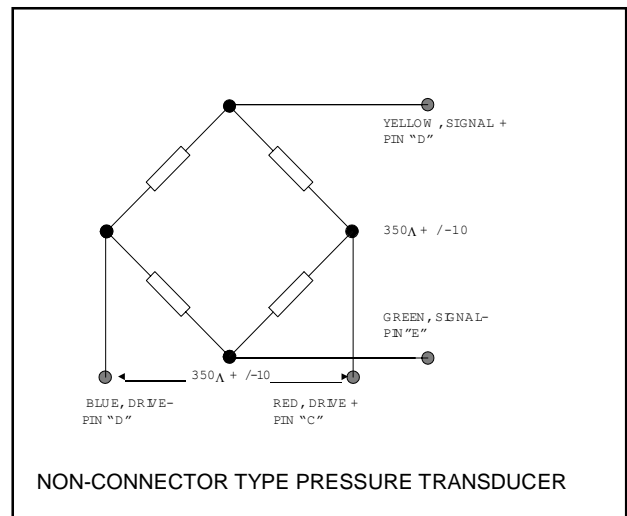
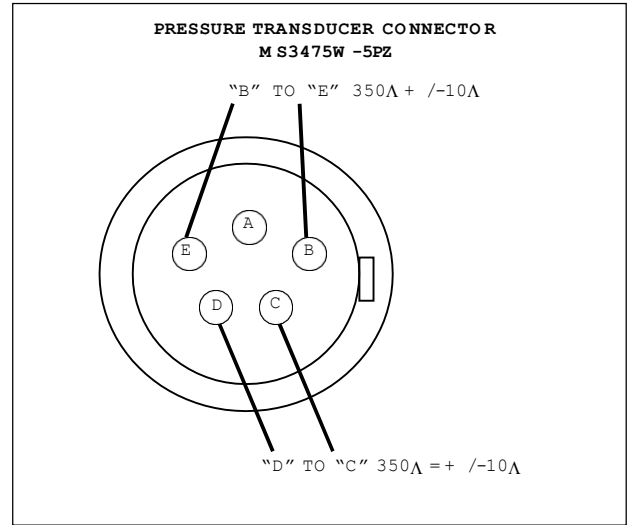

two components. Repair or replace as required.

BOOM EXTENSION SENSOR AIN2

Use the following procedure to check the Boom Extension Sensor Voltage.

1. Fully retract the boom.
2. Access the Relay and Termination Board.
Measure the analog sensor drive voltage (refer to [page 36](#) of this manual).
3. With a digital voltmeter set to read DC voltage place the negative lead on any 0 Volt terminal of the Analog Input Group.
4. Place the positive lead of the meter on the AIN2 2 terminal of the Analog Input Group. The voltage should be $0.25 \text{ volts} \pm 0.1 \text{ volt}$.
5. Extend the boom as far as safe to do. *The boom need not be horizontal for this test.*
6. The voltage should be less than 5 volts. (Usually around 2.5 volts depending on the boom length).
7. During extension the voltage should increase linearly and during retraction the voltage should decrease linearly.
8. If the voltage is out of the range listed above, remove the four screws securing the cover on the extension reel located on the left side of the main boom section and remove the cover.
9. Under the cover on the right side of the extension reel you will see a terminal strip. This terminal strip has six wires connected to the bottom screws.
10. With a digital voltmeter set to read DC Voltage, place the negative lead on the terminal with the blue wire attached to it (- Drive) and the positive lead on the terminal with the red wire attached to it (+Drive).
11. The voltage should be $5.25 \pm 0.1 \text{ volts}$. If this voltage is out of range and the Analog Drive Voltage measured in the computer was OK then it is possible that the cable is open or grounded between the Computer and the Extension Reel. Check all connections and plugs that may be between these

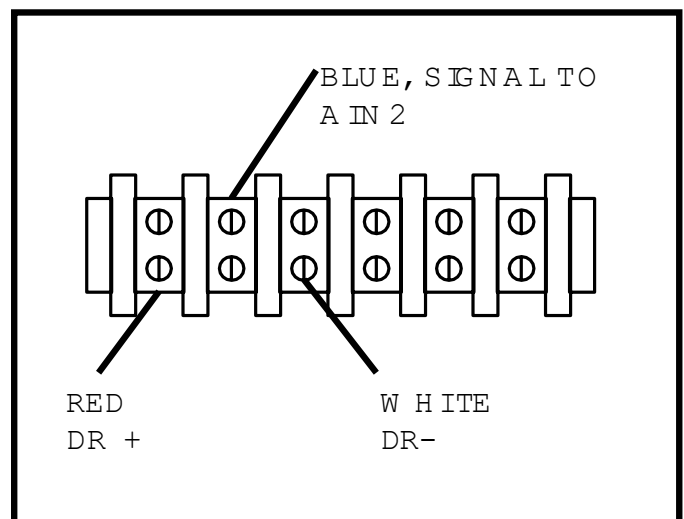

BOOM ANGLE SENSOR AIN3

- Place the main boom at a 0° angle. Verify that it is at a 0° angle with an inclinometer.
- Access the Terminal Connection Board. Check the Analog Drive Voltage. Refer to page 36 of this manual.
- With a digital voltmeter set for DC Volts, connect the negative lead of the meter to any 0 Volt terminal of the Analog Input Group.
- Connect the positive lead to the AIN 3 terminal of the Analog Input Group.
- With the boom horizontal, the voltage should be 0.4 ± 0.1 volts.
- Raise the main boom to a 60° angle. With an inclinometer, verify that the main boom is at a 60° angle.
- With the boom at a 60° angle, the voltage should be 3.02 ± 0.1 volts.
- If this is out of range, remove the cover from the reeling drum located on the left side of the main boom.
- Under the cover on the right side of the extension reel you will see a terminal strip. This terminal strip has six wires connected to the bottom screws.
- With a digital voltmeter set to read DC Voltage, place the negative lead on the terminal with the blue wire attached to it (- Drive) and the positive lead on the terminal with the red wire attached to it (+Drive).
- The voltage should be 5.25 ± 0.1 volts. If this voltage is out of range and the Analog Drive Voltage checked in step 2 was OK, then it is possible that the reeling drum cable is open or grounded between the Computer and the Extension Reel. Check all connections and plugs between these two components. Repair or replace as required. Refer to the MicroGuard® 414 wiring details in the Installation Manual for the model of crane under test.

- With the negative lead of the voltmeter connected to blue, drive negative and the positive lead of the voltmeter connected to green, angle signal, the voltage should be the same as the voltage measured at AIN3 of the analog input group in the computer. If this voltage is not the same it is possible that the cable between the reel and the computer is faulty or the boom angle sensor is faulty.
- If the above voltage checks are within range and no grounds or opens are found in the wires, replace the Boom Angle Sensor as described on [page 44](#) of this manual.

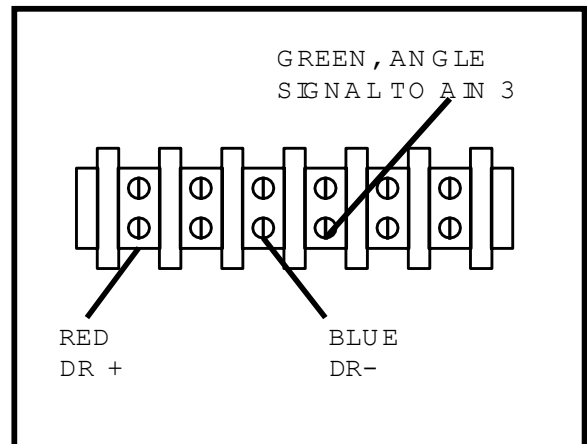
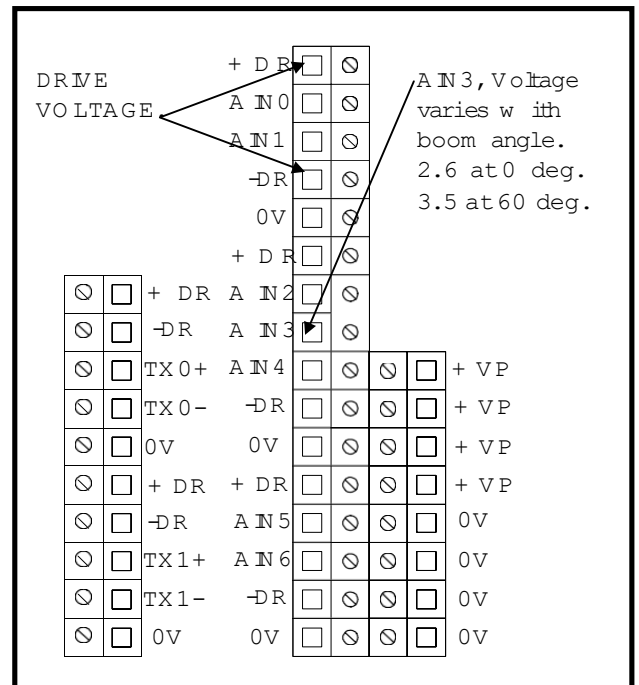

SWING POTENTIOMETER AIN5 AND AIN6

The position of the upper structure in relation to the carrier must be determined. This is accomplished by means of swing potentiometer mounted in the collector ring. If the system does not have an input from the swing potentiometer it will not be able to find a duty.

To check the Swing Potentiometer, use the following procedure:

1. Access the Relay and Termination Board.
Check the Analog Drive Voltage. Refer to [page 33](#) of this manual.
2. With a digital voltmeter set for DC volts check the voltage at the connections to the potentiometer located on the Anti Two-Block board. Connection 1 has a red wire attached to it and connection 3 has a black wire attached to it.
3. Connect the black lead of the DVM to connection 3 (black wire) and the red lead of the DVM to connection 1 (red wire). The voltage should be 4.125 +/- 0.1 volts. If this voltage is out of range the Termination Board will need to be replaced.
4. With the black lead on any 0 Volt terminal, check the voltage at AIN 5 terminal and AIN 6 terminal. The voltage should be 4.50 +/- 0.1 maximum and 0.365 +/- 0.1 minimum. Both of these voltages should rise and fall linearly within this range as the upper is rotated left or right. If the Drive Voltage and the Voltage at the connection to the potentiometer were correct and the voltages on AIN 5 and AIN 6 are out of range the swing potentiometer will need to be replaced.

Contact your distributor or your Factory Service Department for procedures on replacing the swing potentiometer.

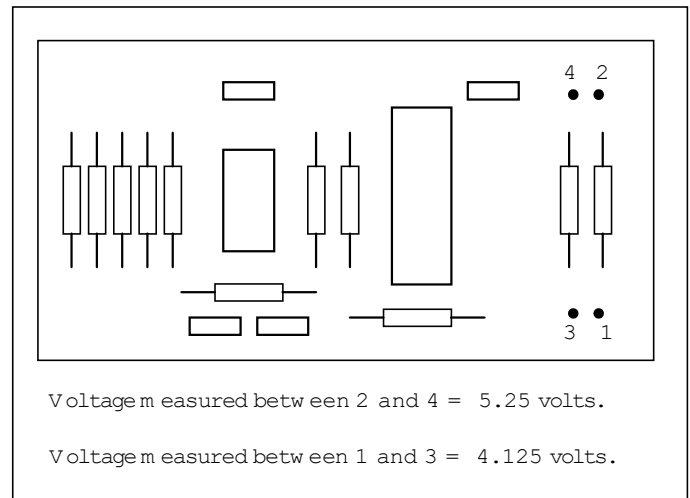
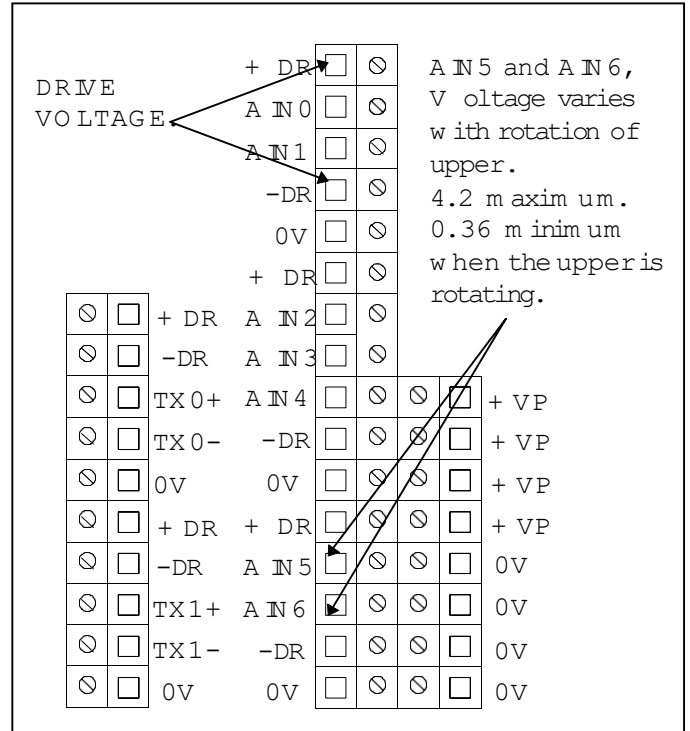

NO DUTY FOUND

The system needs the same information that the operator would need in order to read a load chart. If for any reason this information is not available the fault “ No Duty Found “ will result. This fault could occur if either the Boom Angle Sensor, or Extension Sensor inputs are faulty. The system uses all of these inputs to determine the duty selection. Upon correction of the Sensor fault the system will again be able to find a duty.

OTHER SYSTEM FAULTS

EXECUTIVE ROM

The Executive ROM fault code indicates failure of IC2 on the main computer board. This chip can be replaced without the need for re-calibration. The chip is labeled M414150.

PERSONALITY ROM

The Personality ROM fault code will be present until the system is fully calibrated. At the completion of calibration a code is automatically inserted into the memory which enables the system to carry out the self-test. If the fault code occurs in normal service it could indicate either a failure of IC7 or the loss of data in the device. It will be necessary to obtain a copy of the Personality ROM that was made at the completion of the initial calibration or carry out a complete re-calibration of the system. Contact your Distributor or Factory Service Department for details.

SCRATCHPAD RAM

The Scratchpad Ram fault code indicates the failure of IC6 on the Main Computer Board. This item is not user serviceable and requires the replacement of the Main Computer.

DUTY ROM

This fault is associated with the failure of the Duty Chip IC3 on the Main Computer Board. It can be replaced without the need for re-calibration. It contains the load chart data for the crane on which it is fitted and must be the exact type for the load chart on the machine.

CURRENT DUTY BAD

This fault indicates failure of the Duty Chip IC3 on the Main Computer Board. It can be replaced without the need for re-calibration. It contains the load chart data for the crane on which it is fitted and must be the exact type for the load chart on the machine.

CONFIGURATION UNCALIBRATED

When a machine is initially calibrated its duty chip may contain more configurations than are to be sold with that particular machine. Fly or jib options that are not supplied with the machine will not show up in the Crane Set Up menu. Refer to the Calibration Procedure, Command 13 for details of hiding or showing attachments.

DIGITAL I/O & ANALOG I/O

Digital and Analog I/O faults are not user serviceable. When this fault code is detected it will be necessary to replace the Main Computer Board.

DISPLAY UNIT

This unit is not user serviceable. When this fault code is detected it will be necessary to replace the Display Unit. This can be done by removing the four screws securing the display into the dash and unscrewing the cable from the back of the display. Connect the display cable to the new display, install it into the dash and secure with the four mounting screws.

ANTI TWO BLOCK SYSTEM

SYSTEM WILL NOT SHOW TWO-BLOCK WHEN CRANE IS TWO-BLOCKED:

1. Access the Termination Board (refer to [page 33](#) of this manual).
2. Make certain that the Anti Two-Block weight is attached to the boom head switch and that the selector switch is properly positioned.
3. Remove the brown wire connected to the ATBIN terminal of the digital input group (see page 42). The system should show a Two-Block warning.
4. Connect a jumper wire from the 0 volt terminal to the ATBIN terminal (see page 42). The Two-Block warning should no longer be displayed. If the Two-Block warning remains the problem is in the Termination Board.
5. Remove the jumper wire and reconnect the brown wire to the ATBIN in terminal. Remove the four cover screws from the extension reel located on the left side of the main boom and remove the cover.
6. Remove the brown wire from the terminal strip. The system should show a Two-Block warning. If it does not, the brown wire or its connections between the Terminal Board and the extension reel are grounded. If the system does show a Two-Block warning there is a ground in the wiring or connections between the extension reel and the Switch at the boom head. Check all wires and connections between these two components and repair or replace as required.

SYSTEM SHOWS TWO-BLOCK WHEN CRANE IS NOT TWO-BLOCKED

1. Check that the selection switch of the Two-Block switch located at the main boom head is correctly set.
2. Make certain that the Anti Two-Block weight is attached to the boom head switch.
3. Access the Termination Board.
(Refer to [page 33](#) of this manual).

4. Remove the brown wire connected to ATB in terminal of the digital input group. The system should show a Two-Block warning.
5. Connect a jumper wire from the 0 volt terminal to the ATBIN terminal. The Two-Block warning should no longer be displayed. If the Two-Block warning remains the problem is in the Termination Board assembly. If not, the problem is in the external wiring or switches.
6. Remove the jumper wire and reconnect the brown wire to ATB in terminal. Remove the four screws from the extension reel located on the left side of the main boom.
7. Connect a jumper wire between the black wire and the brown wire on the terminal strip. The Two-Block warning should no longer be displayed. If it remains, the brown wire is open between the Termination Board and the Extension Reel. If the warning is no longer displayed the problem is somewhere between the extension reel and the boom head switch. Check all wires and connections between these two components and repair or replace as required.

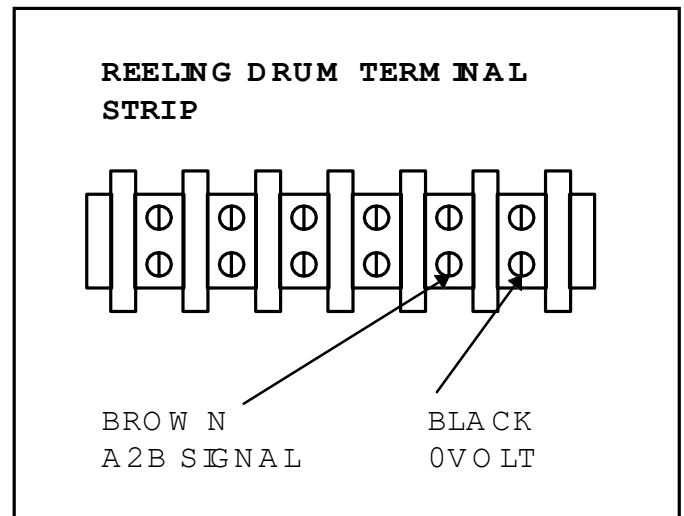

ANTI TWO-BLOCK LOGIC LEVELS

The signal from the ATB switches at the boom and fly tips is a switched ground. The ground signal is sourced in the computer at the **0 volt terminal** of the digital input group.

When there is no ATB alarm, the switches at the boom head are *closed* allowing the ground to be returned to the computer at the **ATBIN** terminal.

When there is a two-block condition the appropriate ATB switch will go to the *open* position thereby removing the ground from ATBIN and causing ATB Alarm and Function Disconnect.

The ATB alarm and Function Disconnects are controlled separately by the ATB board in the computer.

The ATB board, located in the computer box:

- Operates the function disconnects by controlling the coil of RL2, ATB relay, at D OUT 1.
- Operates the audible alarm and on screen message by controlling the logic level at DIN13.

The logic levels are as follows:

	NO ALARM	ATB ALARM
ATB SWITCH	CLOSED	OPEN
ATB IN	LOW 0.2 VOLT	HIGH 5 VOLT
D OUT 1	LOW 0.2 VOLT	HIGH 5 VOLT
D IN 13	HIGH 12 VOLT	LOW 0.2 VOLT

The voltage levels are approximations and small variations are to be expected.

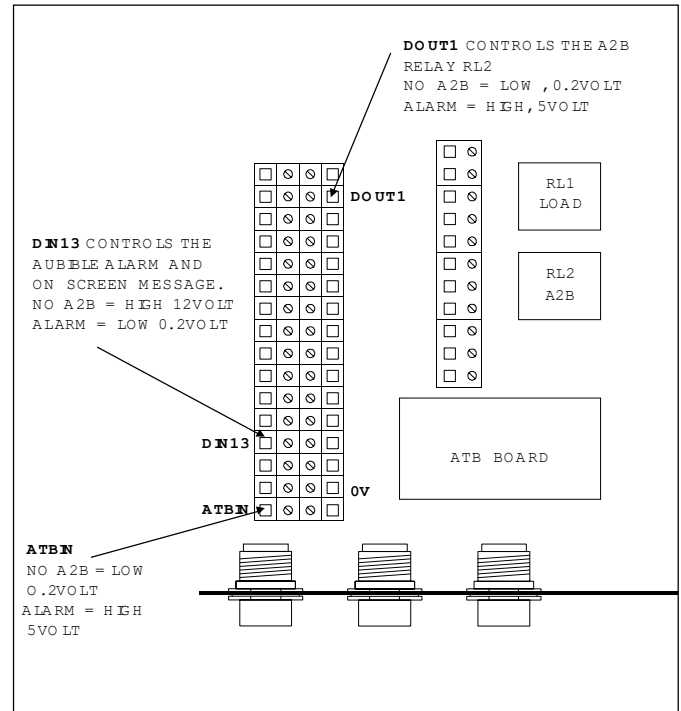

wind the reel in the same direction until the distance between the boom head and the connector is

PARTS REPLACEMENT

PRESSURE TRANSDUCER REPLACEMENT

1. It is recommended that the replacement transducer is closely matched to the sensitivity of the old transducer. The sensitivity value is recorded on the serial number plate.
2. Remove the connector connecting the transducer to be replaced from the computer box.
3. With the boom cylinder completely retracted, in the rest, or with the boom safely supported, remove the transducer to be replaced.
4. Install the new transducer on the boom hoist cylinder.
5. Run the cable to the computer box and connect it to the appropriate computer box connector.
6. Pick a known weight to verify the accuracy of the system. If the load reading is not within tolerance after the replacement of a pressure transducer, carry out Command 6 (Pressure) of the MG414 Calibration procedure.

EXTENSION REEL REPLACEMENT

To replace the extension Reel assembly, use the following procedure:

1. Fully retract the main boom.
2. Disconnect the connector to the Two-Block switch and remove the cable from the main boom head anchor. Allow the cable to retract onto the reel, be careful not to let the cable retract too rapidly.
3. Remove the Extension Reel Cable connector.
4. Remove the four mounting bolts (5) securing the Extension Reel to the boom and remove the reel.
5. Mount the new reel to the boom, secure with the mounting bolts and connect the Extension Reel Cable Connector.
6. Remove the shipping cable clamp from the new cable and allow it to slowly rewind onto the Extension Reel until there is no pre-tension. Continue to re-

approximately 12 ft. At this point there will be no pre-tension.

7. Pull the cable out passing it through the cable guides until the end of the cable is 3 ft. beyond the boom head.
8. Wrap the cable around the boom head anchor a minimum of five times and secure with a wire tie or the shipping cable clamp.
9. Connect the cable to the connector coming from the Two-Block switch.
10. Manually turn the large gear connected to the potentiometer fully counter-clockwise.
11. Observe the length display and turn the large gear at least 3 clicks clockwise until the length display reads the retracted boom length.
12. Replace the Extension Reel Cover, securing it with the four screws.
13. Extend and retract the main boom and see that the boom length reading on the display is correct.

BOOM ANGLE SENSOR REPLACEMENT HTC8660 ONLY

To replace the Boom Angle Sensor use the following procedure:

1. With the power off, disconnect the Boom Angle Sensor cable from the sensor located on the left side of the boom near the boom extension reel.
2. Remove the two bolts securing the sensor to the boom and remove the old sensor.
3. Install the new sensor on the boom, secure it loosely with the mounting bolts and connect the cable.
4. Raise the boom to a 60° angle and verify the angle with an inclinometer. While viewing the display adjust the sensor until the display reads 60° and tighten the mounting bolts.
5. Place the boom horizontal, verify that it is at 0° with an inclinometer.
6. Verify that the displayed boom angle is reading 0° +/- 0.5°.

of this manual.

BOOM ANGLE SENSOR REPLACEMENT

To replace the Boom Angle Sensor that is fitted inside the reeling drum, use the following procedure:

1. With the power off, remove the 4 bolts holding the cover of the reeling drum and remove the cover.
2. Disconnect the 3 wires connecting the angle sensor to the terminal strip. Remove the two bolts securing the sensor to the reeling drum and remove the old angle sensor.
3. Install the new sensor in the reeling drum in the original location, secure it with the mounting bolts and connect the cable.
4. Raise the boom to a 60° angle and verify the angle with an inclinometer. While viewing the display adjust the sensor until the display reads 60° and tighten the mounting bolts.
5. Place the boom horizontal, verify that it is at 0° with an inclinometer.
6. Verify that the displayed boom angle is reading 0° +/- 0.5°.

EXECUTIVE ROM CHIP REPLACEMENT

The Executive ROM Chip contains the main program data that the computer uses to function and must be specific to the system.

1. Access the Main Computer Board. Refer to page 33 of this manual.
2. With the power off remove IC2, the Executive ROM Chip from its socket. Refer to General Chip Removal and Installation (page 45) in this manual.
3. Install the new Executive ROM Chip into the socket. Make certain the notch in the chip is lined up with the notch in the socket and all pins are properly inserted.

PERSONALITY ROM CHIP REPLACEMENT

The Personality ROM Chip must be the proper chip for the particular crane serial number. This chip contains calibration data that is unique to each machine.

1. Access the Main Computer Board. Refer to page 33

2. With the power off, remove IC7 (the Personality ROM Chip) from its socket. Refer to General Chip Removal and Installation (page 45) in this manual.
3. Install the new Personality ROM Chip into the socket. Make certain the notch in the chip is lined up with the notch in the socket and all pins are properly inserted.

DUTY ROM CHIP REPLACEMENT

The Duty ROM Chip must be specific to the load chart used in the machine. This chip contains a copy of the load chart and must match the load chart in the machine.

1. Access the Main Computer Board. Refer to page 33 of this manual.
2. With the power off, remove IC3 (the Duty ROM Chip) from its socket. Refer to General Chip Removal and Installation (page 45) in this manual.
3. Install the new Duty ROM Chip into the socket. Make certain the notch in the chip is lined up with the notch in the socket and all pins are properly inserted.

NOTE: Replacement of the Executive or Duty ROM Chip does NOT necessitate the re-calibration of the system.

NOTE: Replacement of the Personality ROM Chip does NOT necessitate re-calibration of the system if the new Personality ROM Chip is an exact duplicate of the original. If a copy of the Personality Chip is not available the system will need to be completely re-calibrated.

COMPUTER BOARD REPLACEMENT

1. With the power off, access the Computer Board. Refer to page 33 of this manual.
2. Locate the two ribbon cables connecting the Computer Board to the Termination Board.
3. The ribbon cables are held in place by two locking tabs on each cable end. These locking tabs must be pushed away from the cable to disconnect the

cable. As the locking tabs are pushed the connector will come loose from the Main Computer Board.

4. Loosen the two screws holding the Computer backing plate to the box.
5. Remove the Computer Board Assembly.

4. Remove the Computer Box.

There are three computer chips on the Main Computer Board that must be of the correct type. These three chips are:

IC2 Executive ROM

IC3 Duty ROM

IC7 Personality ROM

The Executive ROM must be specific to the system.

The Duty ROM contains a copy of the load chart and must correspond to the Load Chart Number of the particular serial number machine.

The Personality ROM contains data that is unique to the particular serial number machine.

6. Install the:
 - Executive ROM Chip.
 - Duty ROM Chip.
 - Personality ROM Chip.
7. Place the Main Computer Assembly into the computer box and tighten the two mounting screws, make certain to allow access to the ribbon cables.
8. Reconnect the two Ribbon Cables being certain to fully engage the connector and locking tabs
9. Replace the Computer Box cover and secure with the four screws.

COMPUTER BOX REPLACEMENT

TERMINAL BOARD AND BOX ONLY. USE THE COMPUTER BOARD FROM THE ORIGINAL BOX.

1. Remove the Main Computer Board.
2. Disconnect all cable connectors from the Computer Box.
3. Remove the four screws securing the Computer Box.

5. Install the new computer and secure with the four mounting screws.
6. Reconnect all cable connectors.

NOTE THAT CONNECTORS 1 AND 2 ARE SIMILAR AND THEY ARE COLOR-CODED AND MUST BE CONNECTED WITH THE COLOR ON THE CABLE MATCHING THE COLOR ON THE SOCKET.

CHIP REMOVAL AND INSTALLATION

When removing and installing chips be certain the power is switched off. Do not touch the chip pins unless you are properly grounded. Static electricity can damage chips.

1. Make certain the power is off.
2. Remove the chip to be replaced with a chip removal tool.
NOTE: Chip removal and installation tools are available from any electronics store.
3. Insert the new chip into the installation tool per the instructions on the package.
4. Insert the new chip into the socket, making certain that the notch in the chip (1) lines up with the notch in the socket (2).
5. Double check that all pins are properly inserted into the chip socket. These pins are very easily bent. Failure to have all pins inserted can cause damage to the system and the chip.

GLOSSARY OF TERMS

ABORT	The premature termination of a data entry procedure.
ALARM	A signal that warns or alerts such as a flashing light or loud noise.
AMPLIFIER	A device which takes an input and produces an output of greater magnitude (as in the case of a pressure transducer where a signal in the millivolt range is amplified to the level of up to ten volts).
AMPLIFIER GAIN	The factor used to express the level of amplification.
ANALOG	A mechanism in which data is represented by continuously variable physical quantities.
ANGLE SENSOR	A device which measures the inclination of a boom.
ANNULAR	Relating to, or forming a ring. e.g. the pressure around the rod of a boom hoist cylinder.
ANNULAR GAIN	The factor used to modify the pressure signal from the rod side of the boom hoist cylinder based on the difference in areas of the rod and bore.
BACK-UP	Move data from the working area of memory to a microchip that is stored elsewhere e.g. in a service department.
BOOM DEFLECTION	The change of radius due to the bending of a boom under load.
BOOM MOMENT	The turning moment around the boom pivot caused by the moment of the unladen boom.
BORE	The piston side of a boom hoist cylinder.
CALIBRATION	The adjustment of the graduation of sensors.
CAPACITY CHART	A table showing the rating of a crane.
CENTER OF GRAVITY	The point at which the entire weight of a body may be considered as concentrated so that if supported at this point the body would remain in equilibrium in any position.
COMMISSIONING	Preparing to be put into service.
CONFIGURATION	An arrangement of the lifting elements of a crane.
CURSOR	A pointer on a display which indicates the position where data is to be entered.
DATA	Factual information used as a basis for calculation.
DECREMENT	The action of decreasing a number or value.
DEDUCT	A reduction in rated capacity for an unused stowed or erected attachment.
DEFLECTION	The bending of a boom or the stretching of pendant lines within the elastic limits of the boom or pendants.
DIGITAL	Operating with numbers expressed directly as digits.
DIGITAL INPUTS	Computer inputs which usually are either on or off as determined by external switches.
DIRECTION	The direction of rotation of the superstructure.
DUTY	A working configuration on a crane usually contained in a single column of a capacity chart.
EEPROM	Electrically erasable and programmable "read only" memory. (ROM)

ELASTIC	Capable of recovering size or shape after deformation.
ERECTED ATTACHMENT	An attachment on the main boom fitted in its working position.
EXTENSION SENSOR	A device which measures the extension of the telescoping sections of a boom.
FLY/JIB	Something attached by one edge such as a lattice fly or jib on a crane boom.
FORCE	Energy exerted, in this case by the suspended weight of an object.
GEOMETRY	A branch of mathematics that deals with the measurement and relationships of points, lines, angles, surfaces and solids.
GRADUATED	Marked with degrees of measurement.
HEIGHT	The vertical distance from the ground to the tip of the boom or attachment.
HITE	An abbreviation of the word height. The height of the boom pivot above ground level.
HORIZONTAL	Parallel to the horizon.
HYDRAULIC CRANES	Operated using the pressure of oil.
INCREMENT	The action of increasing a number or value.
INITIALIZE	Erase all data from a memory prior to a new calibration.
INTEGRATED CIRCUITS	A tiny complex of electronic components and connections on a small slice of material (such as silicon).
MEASURE HEIGHT	The vertical distance below the boom pivot at which radius measurements are to be made when calibrating.
MICROPROCESSOR	A computer processor contained on an integrated chip.
MILLIVOLT	One thousandth of a volt.
MOMENT	The product of force and distance to a particular axis or point.
OUT OF DUTY	A point which is either longer than the longest permitted radius or lower than the lowest permitted angle on a capacity chart
OUTRIGGER	A projecting support run out from a main structure to provide additional stability or support.
PERSONALITY	Data stored in the calibration EEPROM.
PRESSURE	Hydraulic pressure in the boom hoist cylinder
RADIUS	The horizontal distance from the center line of rotation to the center of the hook.
RATED CAPACITY	The lifting capacity of a crane as determined by the published capacity chart.
RATED CAPACITY	The load that a crane can safely handle based on factors such as strength, stability and rating.
RATING	A factor determined by legislation that limits the proportion of a cranes capabilities which may be utilized in a lifting operation. Usually expressed as a percentage of strength or stability.
RESTORE	Move data from a back-up chip into the working personality.

ROM	"Read only" memory from which data can only be read, i.e. not changed after programming.
ROPE LIMIT	The maximum permitted single line pull determined by the construction and diameter of a wire rope.
SAVE	Move data from the working personality to a write protected area of memory.
SCALE	The use of a factor to set the scaling of analog sensors.
SCALE	Something graduated when used in measurement.
SENSITIVITY	A measure of the capacity of a sensor to respond to physical stimulus.
SENSOR	A device that responds to a physical stimulus and transmits a resulting impulse.
SHEAVE	A grooved wheel or pulley.
SLEW OFFSET	The horizontal distance from the boom pivot to the center of rotation
SPAN	An extent or spread between two limits.
SPAN	The calibration of an analog sensor between zero and maximum span.
STOWED ATTACHMENT	An attachment usually stowed on the main boom when not in use.
SUPERSTRUCTURE	The structural part of a crane above the carrier, usually rotating.
SWING	The rotation of a crane upper around its center line.
SWL (%SWL)	Percentage of safe working load. The proportion of the crane capacity which is being utilized at any one time expressed as a percentage of rated capacity
TRANSDUCER	A device which is actuated by energy from one system and converts this to another form for use by a different system (as a loudspeaker that is actuated by electrical signals and supplies acoustic power).
TX.0	The piston side pressure transducer.
TX.1	The rod side pressure transducer.
UNLADEN	A boom which has no additional stowed or erected attachments and which is not supporting a load.
VOLT	Unit of electrical potential difference and electromotive force.
WEIGHT	The amount that a body weighs or the poundage to be carried by a horse in a handicap race.
WRITE PROTECTED	An area of memory to which a microprocessor cannot write data.
ZERO	The point from which graduation of a scale begins.

COMPUTER BOARD LAYOUT

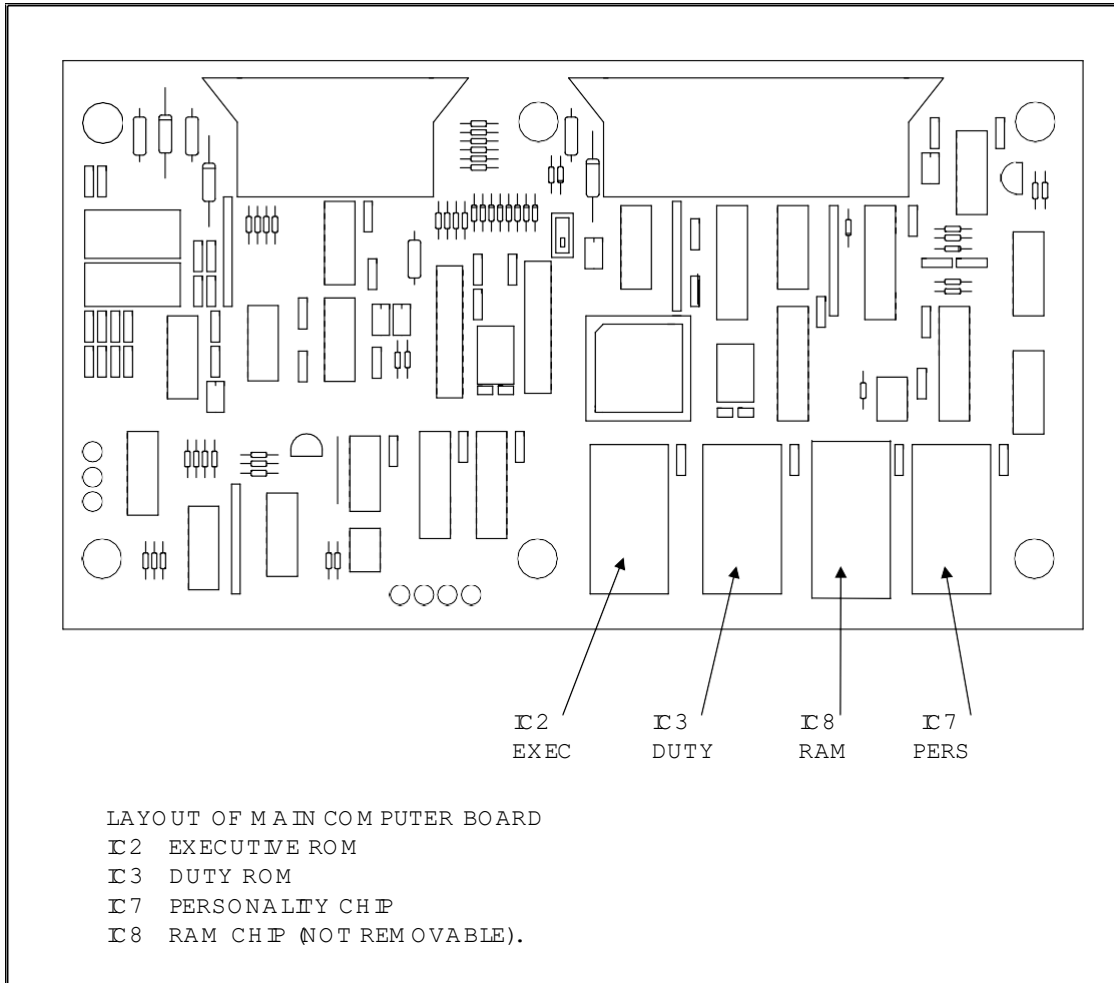

TERMINATION BOARD

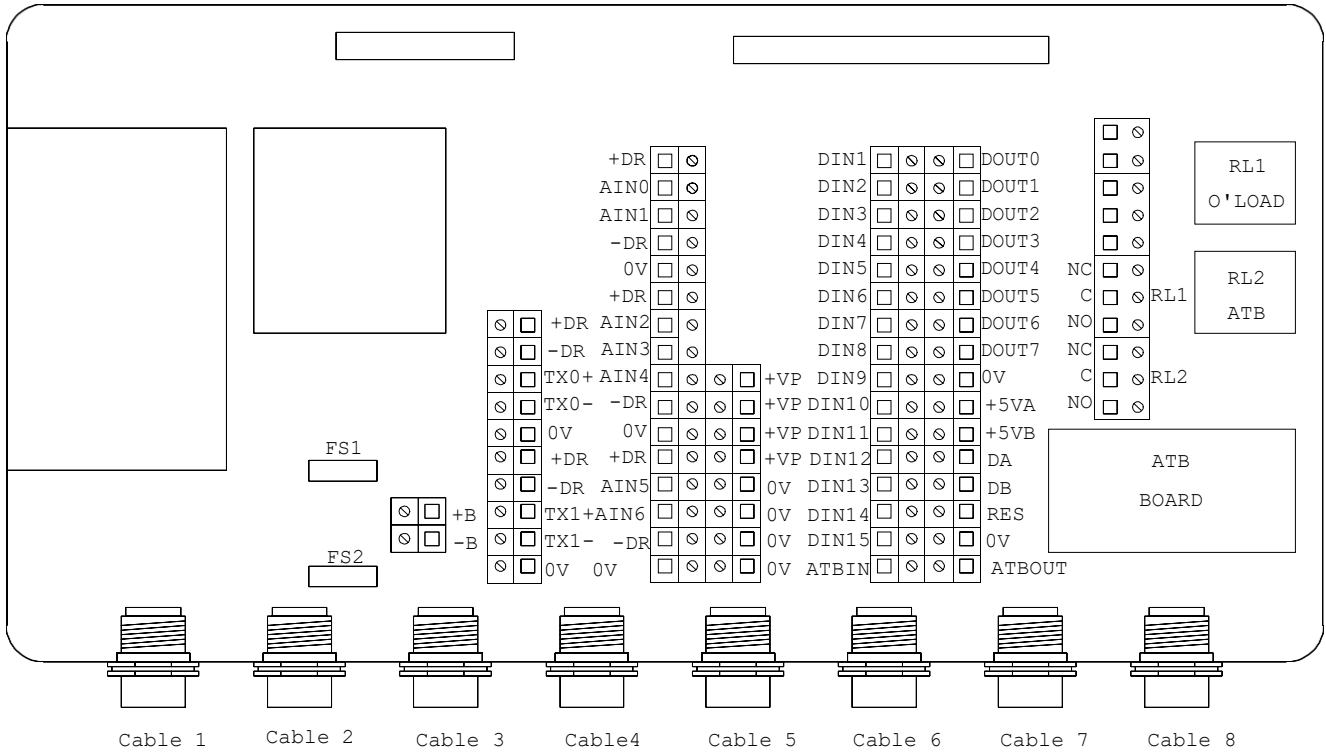

EXTENSION REEL LAYOUT

