

# Altec LMAP

(Load Moment and Area Protection)

Telescopic Boom Cranes

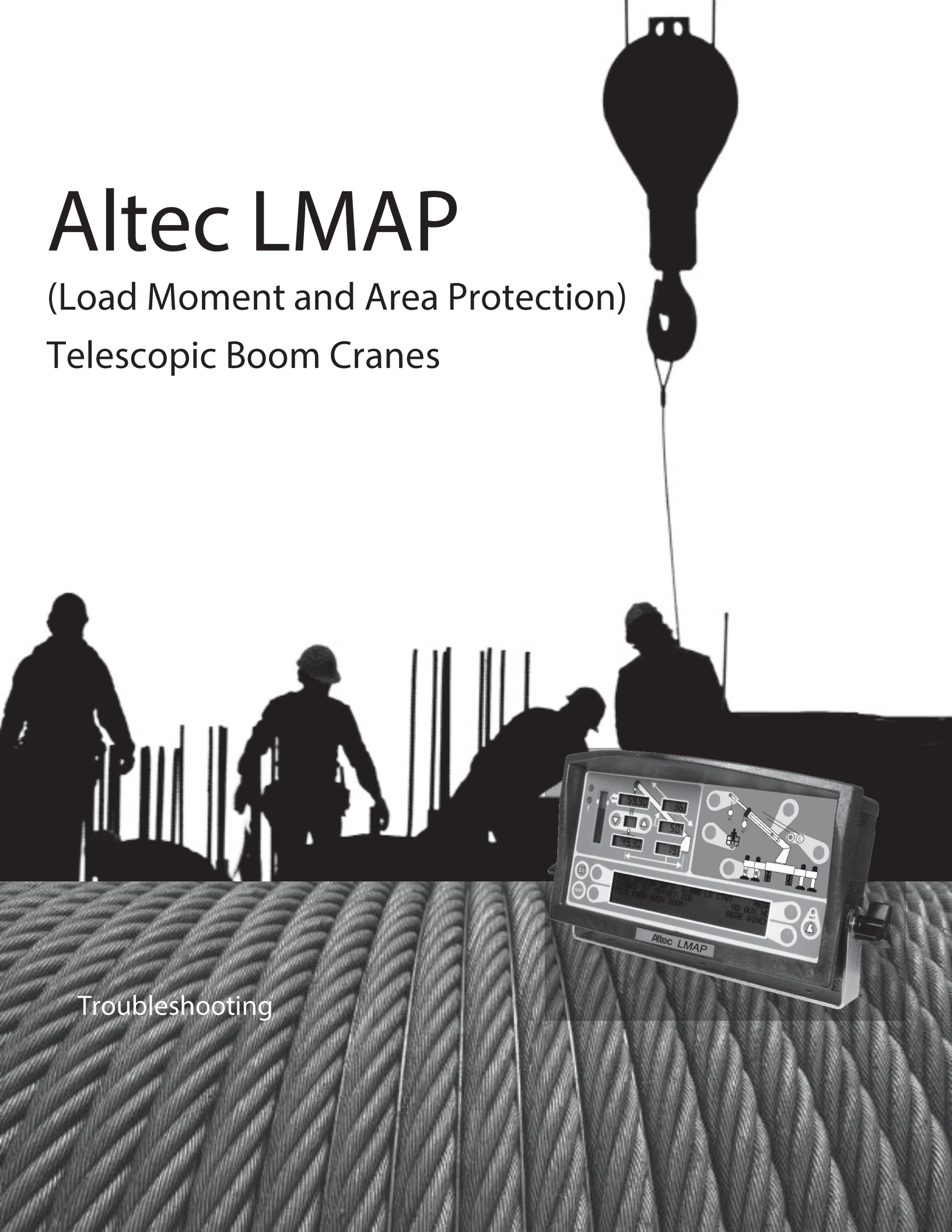

Troubleshooting



## **PSR Professional Service & Repair Inc.**

Professional Service & Repair Inc. is a full-service mobile crane repair, inspection, and certification company. At Professional Service & Repair we understand the critical aspect of your crane being operational to your project schedule and budget. We will deliver world class service to have your crane operational in the minimum amount of time.

PSR is the global provider for sales, repair and installation of Load Moment Indicating (LMI) systems, Anti-Two Block Systems (A2B), and Rated Capacity Indicating systems. Please contact us with your crane repair and certification needs today.

PSR is the name businesses trust for crane repair, inspection, and certification.

**Main Line: 706-718-0856**

**Fax: 706-569-7004**

**E-Mail: [jeff@psrinc.biz](mailto:jeff@psrinc.biz)**

**P.O. Box 6506  
Columbus, GA  
31917-6506**

# Contents

Introduction.....	1
Required Tools.....	1
The LMAP System.....	1
Troubleshooting Table.....	2
LMAP Display.....	3
Reading the (Liquid Crystal) Displays.....	3
LMAP Computer.....	4
Computer Internal Status Indicators.....	5
Power Indicator States and Actions.....	6
Communication Indicator.....	6
Terminal Block Positions and Functions.....	7
Hydraulic Connections.....	8
Check Point.....	8
Checking Functionality of the Load Sensors (Transducers).....	8
Computer Replacement.....	9
Reeling Drum.....	10
Reel-Off Cable.....	10
Check Points.....	10
Computer Cable.....	10
Slip Ring Assembly.....	11
Sensor Baseplate Assembly.....	11
Diagnosis of load and radius errors as displayed on the display console.....	12
Reeling Drum Troubleshooting Table.....	13
Anti-Two Block.....	14
The Anti-Two-Block Weight.....	14
Check Points.....	14
The Anti-Two-Block Switch.....	14
Checkpoints.....	14
Checking the Two-Block Warning Signals and Cutout of Machine Motions.....	14
ATB Troubleshooting Table.....	15
Swing.....	16
Error Codes.....	17

Fault Reporting And Fault Codes.....	17
Group "A"Fault Codes.....	18
Group "B"Fault Codes.....	19
Group "C"Fault Codes.....	20
Group "D"Fault Codes.....	21
System Maintenance.....	22
Crane configuration and system setup.....	22
Extension reel, Reel-off cable to boom tip, extension reel cable to computer.....	22
Hydraulic connections.....	23
Anti-two-block weight.....	23
Anti-two-block switch.....	23
Checking the two-block warning signals and cutout of machine motions.....	23
Computer Cable.....	24
Load Test.....	24

# Introduction

This troubleshooting manual for the LMAP (Load Moment Area Protection System, hereinafter referred to as “the system”) provides information and methods for isolating problems that may arise during operation of the system. Some of these problems can be corrected in the field. Other problems may require replacement of parts or a return of a part to the factory for servicing. Service personnel should have prior training and experience in the procedure for operation and setup of this system.

## Required Tools

The procedures in this manual, where possible, are based on crane operation and function. A basic tool kit consisting of wrenches and screwdrivers (flat and Phillips’ blades) will be required to remove covers and units for inspection. A digital multimeter (DMM) may be required. The DMM must be capable of measuring DC voltage with a range of 0 volts to  $\pm 50$  volts and resolution of 0.1 volts. Resistance range is 0 ohms to 2 megohms. Low cost analog meters are not appropriate since the input impedance of these meters can give false readings.

## The LMAP System

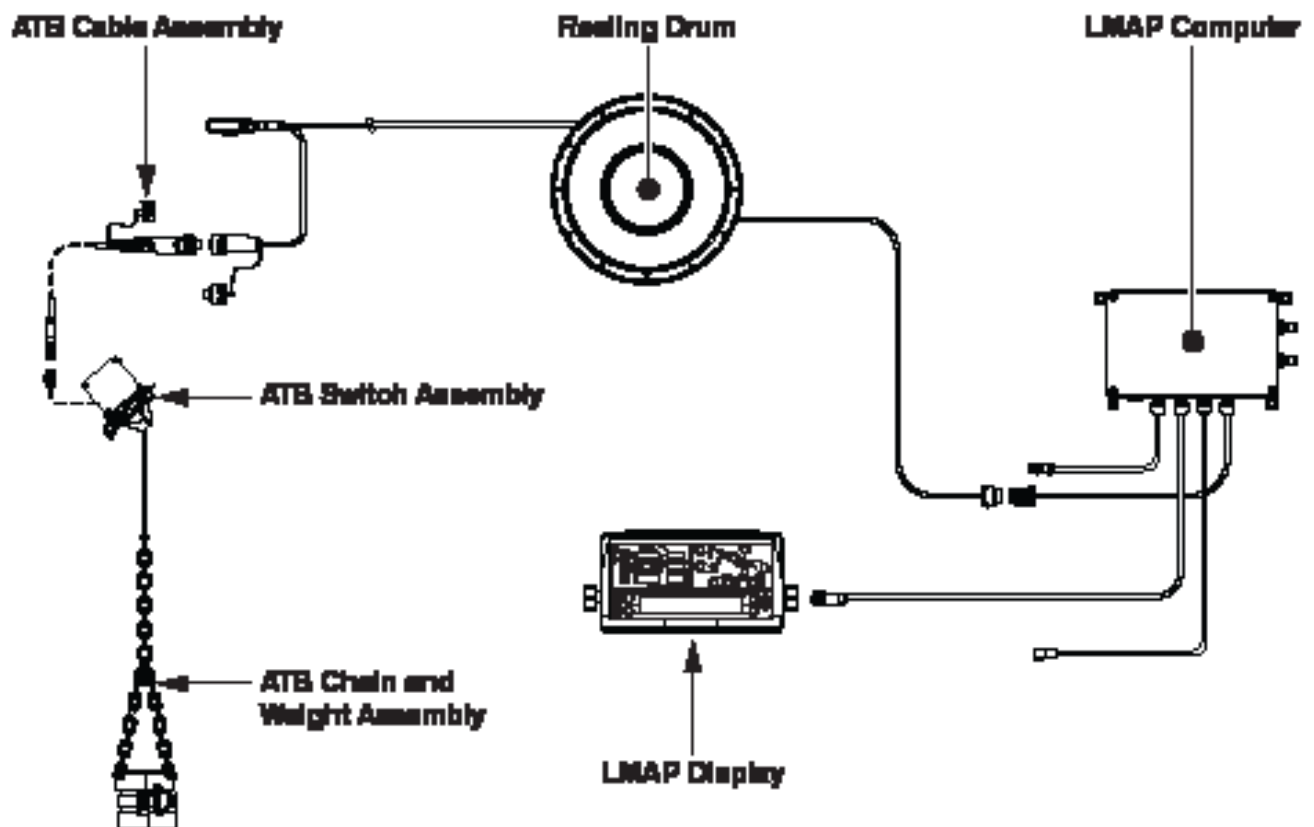

- o LMAP Display – The LMAP display unit has the job of displaying all of the information supplied by the computer, and gives the following information:
  - Displays maximum capacity and percent rated capacity for any given configuration.
  - Warns of an approaching overload or two-block condition for each crane configuration.
  - Features Area Protection alarms that can be set up to aid the operator in avoiding obstacles on the worksite.

- o LMAP Computer – The LMAP computer is mounted inside the crane console. The enclosure contains the computer board and transducers and is a completely pre-calibrated unit. The only calibration that is required is a calibration set-up process that enables us to give the computer a “0” (or starting point) and a place to end the function spans. The entire calibration process usually takes 30 to 60 minutes.
- o Reeling Drum – The primary function of the reeling drum is to house the ATB cable and sensors for Boom Angle and Boom Length. The spring needs 5 “pre-tension” turns in order to hold tension on the cable and make sure it returns properly. The cable on this reel, by design winds on with a single layer of cable. This is necessary in order to protect the accuracy of the length. The controlling factor for this is dimensioning of the 1st cable guide. It is also a junction point for the ATB feed voltage passing through the boom tip switch and returning to the computer.
- o ATB Switch Assembly – The ATB switch is located at the tip of the boom and is used to connect or disconnect the ATB circuit relay. When the switch is opened, the power is taken away from the relay powering the unloader function, and any functions that will further or worsen the condition will be temporarily discontinued. (Boom Down, Winch Up, ExtendOut)
- o ATB Weight and Chain – The ATB weight and chain assembly provides a mechanism for the ATB switch to operate. The ATB switch is normally an open switch, being held closed by the weight of the ATB weight and chain.

## Troubleshooting Table

<b>Types of Problems you may encounter</b>	<b>Where to find the solution</b>
ATB Problems	Anti Two-Block on page 14; Reeling Drum on page 10
Length & Angle Problems	Reeling Drum on page 10
Load Problems	Reeling Drum on page 10; LMAP Computer on page 4
Radius Problems	Reeling Drum on page 10
Swing Problems	LMAP Computer on page 4; Swing on page 17
Error Codes	Error Codes on page 19

## LMAP Display

The operator's display console is normally very reliable. To help identify subtle faults that are sometimes difficult to find, or that may be attributed, mistakenly, to other kinds of problems, please review the following comments.

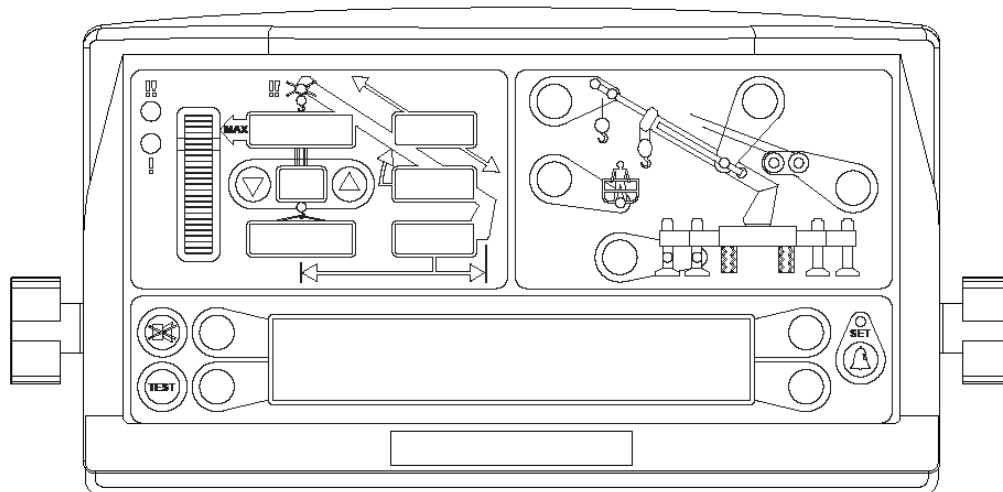

### Reading the (Liquid Crystal) Displays

The most commonly encountered problems with viewing the display is caused by reflections. Use the contrast and brightness adjustment controls to adjust the display to the current lighting condition (see "Adjusting Brightness & Contrast" on page 5 of the Operation Manual). Otherwise, reposition the display console in such a way that sunlight or other bright light source is not shining on it directly. It may not be possible to correct this problem completely.

### Buttons That Don't Respond

All button options are not available for use at all times. Ensure that the non-responsive button is programmed to respond at that point in the operation of the system. Press the button in the center. Pressing the printed symbol 'at one end' may not activate the switch underneath. Buttons that are damaged or have a surface that is worn may cause the switch underneath to operate improperly.

### Connectors

A single circular connector is positioned on the rear of the display console. This connector carries power and signals from the computer unit to the display console. Examine this connector carefully. The connector is "keyed", meaning that it can only be inserted in one direction. Do not try to force the connector into the back of the display as it is possible for the pins and sockets within the connector halves to bend, break, or 'be pushed back' inside the housing.

# LMAP Computer

The LMAP Computer unit has a waterproof soft-formed seal in the lid to prevent water from entering. There are a limited number of user replaceable parts, and these are:

- o 10 Amp FKO Fuse
- o System Program Chip (EPROM).
- o Cable Assemblies
- o Terminal Blocks

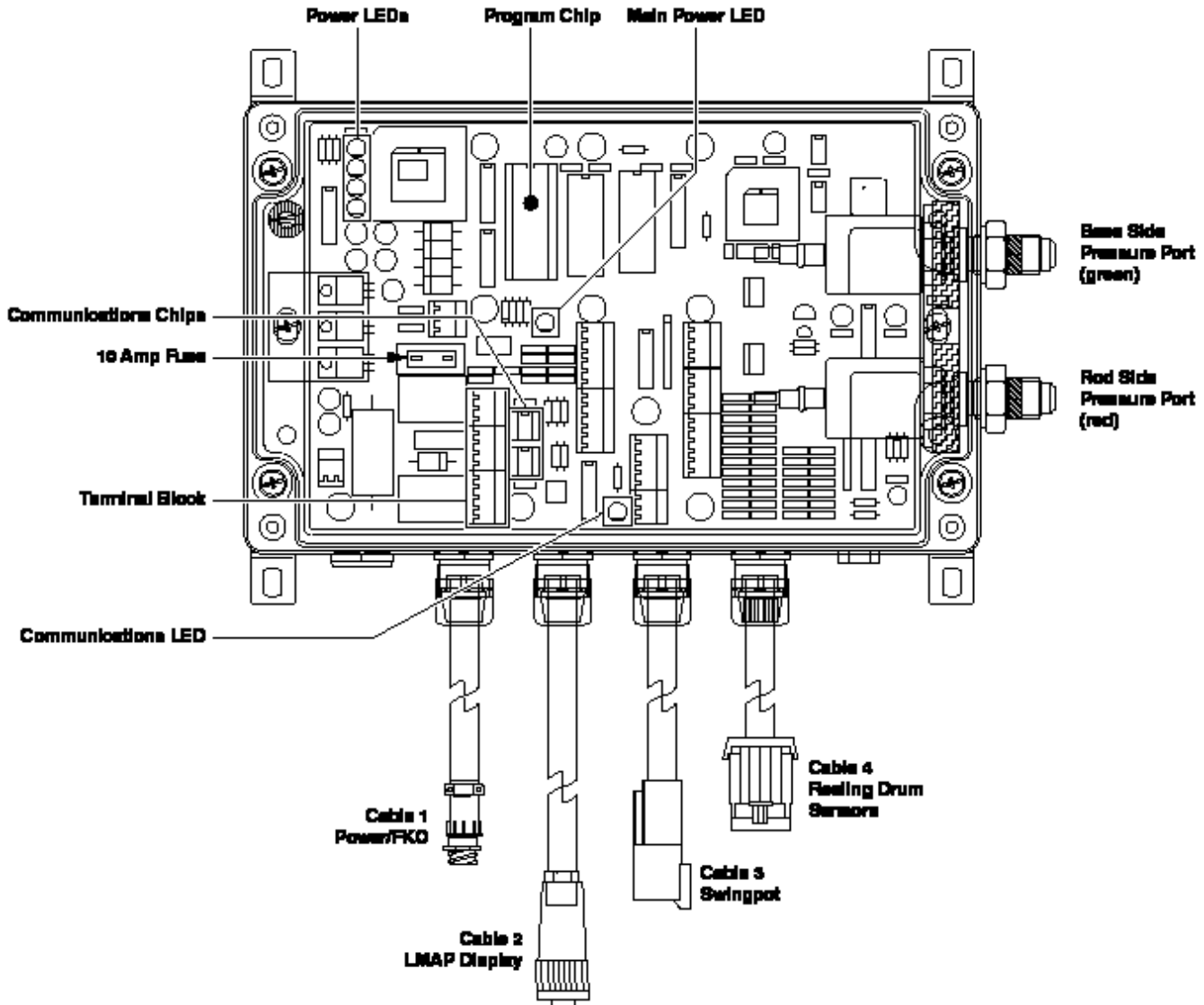

## mWARNING

WHEN REMOVING AND INSTALLING ANY OF THESE COMPONENTS, ALWAYS MAKE SURE THAT THE CRANE POWER IS TURNED OFF AND PROPER TOOLING IS USED, AS DAMAGE COULD OCCUR.

The transducers for the computer unit are not field replaceable, as they are pre-matched at the factory during the calibration process. If the transducers are defective, the unit must be returned to the factory for repair and re-calibration.



The computer is capable of self-diagnostics, and this process is done with a series of board mounted green LED's that measure system voltages.

This is not displayed in voltage measurements, but rather by consistent brightness of the LED. If the LED is lit and the light output is consistent with the other LED's, then the voltage supply is okay, and no other voltage checks inside the computer are required. However, if there are dim or missing LED's it could be a sign of a failing power supply, a short in a wiring harness, or shorted or dirty connectors.

### Computer Internal Status Indicators

The computer unit contains six LED indicators that provide an aid to checking presence of power supply voltages and communications between the computer and display console. There are five power indicators (D2 through D6) and one communications indicator (D7), all Indicators are bright green light emitting diodes.

With the exception of the communications indicator, all indicators should be illuminated at the same brightness level with the system power on. A missing or dimly lit indicator indicates a power supply problem.

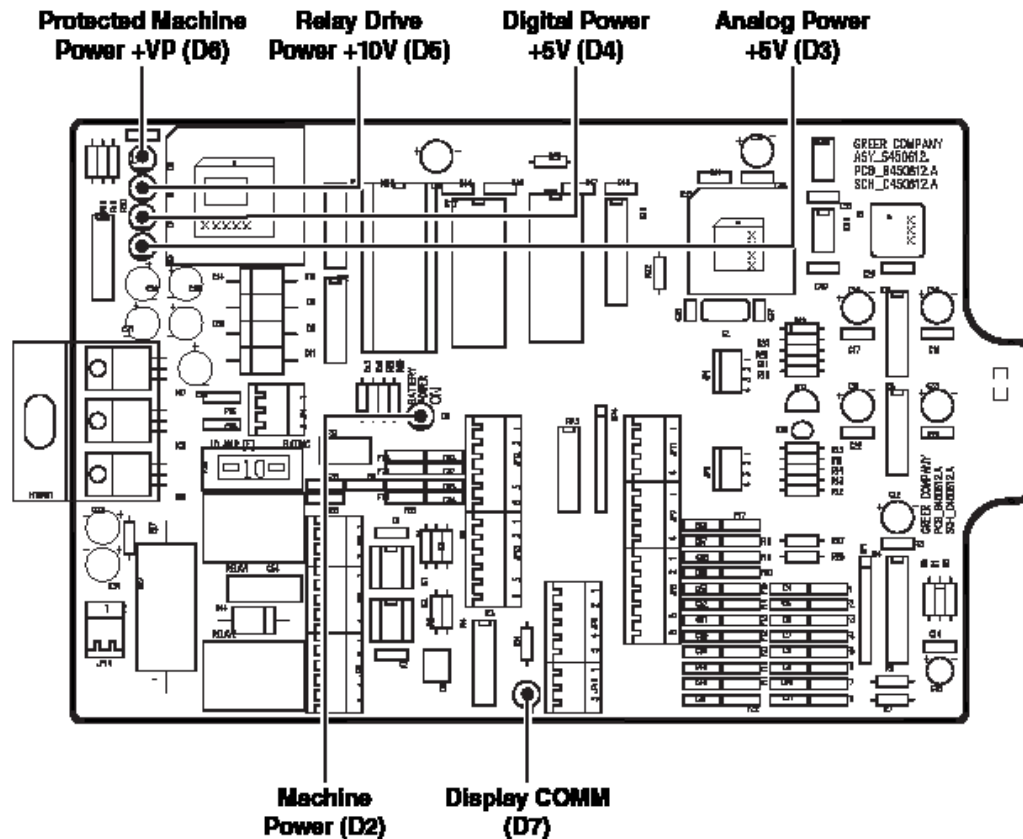

## Power Indicator States and Actions

Power Indicator State	Action
All indicators OFF	<ul style="list-style-type: none"> <li>Check power and ensure that PTO switch is properly engaged.</li> </ul>
D2 ON but all other indicators OFF	<ul style="list-style-type: none"> <li>Check display console cable and connection.</li> </ul>
D5 OFF but all other indicators ON	<ul style="list-style-type: none"> <li>Replace computer</li> </ul>
D3, D4 and D7 OFF but all other indicators ON	<ul style="list-style-type: none"> <li>Replace computer</li> </ul>
D3 OFF but all other indicators ON	<ul style="list-style-type: none"> <li>Check extension reel signal cable and internal voltages within extension reel.</li> </ul>

## Communication Indicator

The Communication Indicator provides an indication of the success or otherwise of communication with the display console, and of the running state of the computer program.

Carefully observe the Communication indicator and the display console at power on and through self-test, and then use the following chart to help decide the course of action.

Communication Indicator Indications At Power On	Action
From the moment system power is applied, the COMM indicator does not illuminate. During and after the self-test the indicator remains off. The display never lights up or shows any information.	<ul style="list-style-type: none"> <li>Check computer status indicators (D2 though D6) If they are off check incoming power to computer.</li> <li>Check display cable for continuity</li> <li>If available test a known good display to make sure the computer is operating properly</li> </ul>
From the moment system power is applied, the COMM indicator does not illuminate. The display reads "No Communication with MicroGaurd".	<ul style="list-style-type: none"> <li>Make sure the display cable and connector is not damaged.</li> <li>Make sure the EPROM is installed the right way up, all the pins are inserted, and it is fully seated in the socket. If the EPROM is installed correctly then install a new EPROM.</li> <li>Test a known good display if available.</li> </ul>
When power is applied the COMM indicator flashes briefly, the switches off. After a few seconds the COMM indicator starts to flash at a fast rate and never stops.	<ul style="list-style-type: none"> <li>This is the normal operation of the communication between the computer and display console.</li> </ul>

## Terminal Block Positions and Functions

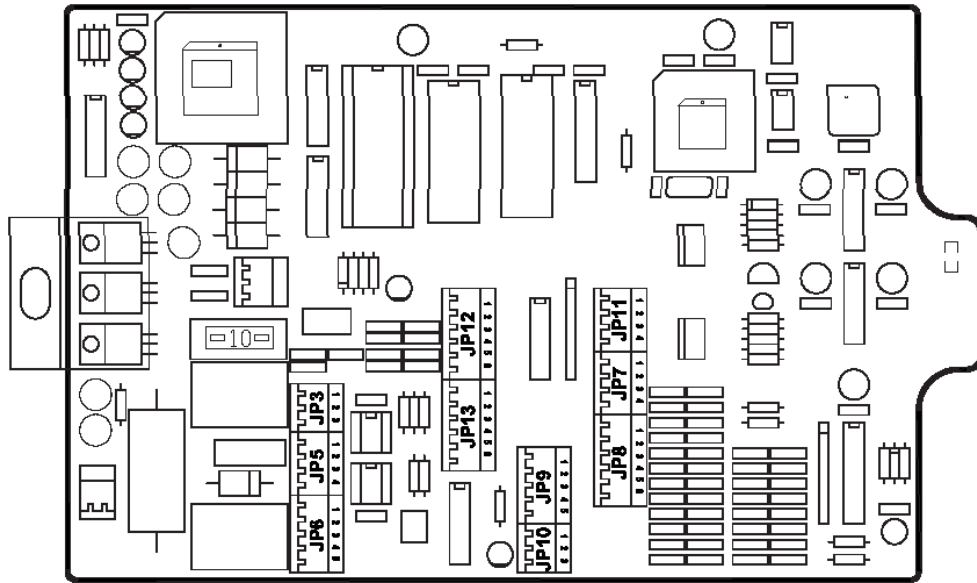

CABLE 1: Power and FKO Connections		
Wire Number	Function	Connection
4	System Ground	JP3-1 (Battery -VE)
3	System Power	JP3-2 (Battery +VE)
Jumper (Red)	System Supply	JP3-3 (Battery +VE)
	Power Feed to FKO Relays	JP5-1 (FKO In)
2	FKO Output to Mach. Solenoids	JP5-2 (FKO Out)
Empty	Not Used	JP5-3 (RLY3 NO)
1	Relay (normally closed)	JP5-4 (RLY3 NC)

CABLE 2: Display Connections		
Wire Number	Function	Connection
2	Communication A	JP12-1 (Display Data A)
3	Communication B	JP12-2 (Display Data B)
4	Reset	JP12-3 (Reset)
1	+ Power	JP12-4 (DSPLY 1 PWR)
Yellow	- Power	JP12-5 (DSPLY 1 GND)
	Not Used	JP12-6 (DSPLY 1 GND)

CABLE 3: Swing Connections		
Swing Pot Connections		
Color	Function	Connection
Red		JP11-1 (Positive Drive)
Black		JP11-2 (Negative Drive)
White		JP11-3 (Swing Signal "A")

Green		JP11-4 (Swing Signal "B")
-------	--	---------------------------

CABLE 4: Extension Reel Connections		
Designation	Function	Connection
Black	ATB Switch Feed (2)	JP8-1 (ATB FD)
White	Extension Sensor Signal	JP8-2 (BM EXTN SIG)
Green	Angle Sensor Signal	JP8-3 (BM ANG SIG)
Orange	ATB Switch Signal (1)	JP8-4 (ATB SIG)
Red	+ Sensor Drive	JP8-5 (BM SNSR +DR)
Blue	- Sensor Drive	JP8-6 (BM SNSR -DR)

## Hydraulic Connections

The two hydraulic pressure sensors, mounted in the computer, measure the pressure within each side of the boom hoist cylinder. The pressure sensors are connected to the boom hoist cylinder valve block by two flexible hoses. Both hoses' are subject to the full hydraulic pressure contained within the piston and rod side of the boom lift cylinder.

### Check Point

Ensure that there are no hydraulic leaks at either connection end of both hoses. Check for signs of wear or damage along the length of each hose.

## Checking Functionality of the Load Sensors (Transducers)

<p><b>Check operation of transducers</b></p>	<ol style="list-style-type: none"> <li>1. Enter calibration mode (refer to Calibration Manual).</li> <li>2. Go to menu "15 - Pressure Monitor" to view both sensor pressures and net pressure.</li> <li>3. As you boom up you should see the piston pressure rise and the rod pressure stay the same or lower.</li> <li>4. As you boom down you should see the rod pressure rise and the piston pressure stay the same or lower.</li> </ol>
<p><b>Check zero calibration of transducers</b></p> <ul style="list-style-type: none"> <li>o Start with the boom at the bottom of its stroke to ensure minimal hydraulic pressure.</li> <li>o Loosen both hydraulic connections to ensure the transducers are at atmospheric pressure or "0"..</li> <li>o The pressure sensing system is factory calibrated, therefore pressure sensors may not be individually replaced. Any problems with the Pressure Sensor (Transducer) will necessitate changing the whole computer unit</li> </ul>	<ol style="list-style-type: none"> <li>1. Enter calibration mode (refer to Calibration Manual).</li> <li>2. Go to menu "15 - Pressure Monitor" to view both sensor pressures and net pressure.</li> <li>3. Check the pressure values of both sensors. The pressure values should be between -75 and +75 PSI. If they are not, the computer unit must be replaced.</li> <li>4. Check the NETT pressure. This should be between -35 and +35 psi. If they are not, the computer unit should be replaced.</li> </ol>

## Computer Replacement

To remove the computer unit:

1. Place the boom in its rest.
2. Turn off electrical power.
3. Disconnect all electrical connectors from the computer.
4. Disconnect hydraulic hose connections from the computer.
5. Remove computer from mounting.

### **mWARNING**

THE HYDRAULIC HOSES CONNECT DIRECTLY TO THE BOOM HOIST CYLINDER. DO NOT OPERATE THE CRANE UNLESS THE COMPUTER HAS BEEN PROPERLY REPLACED OR THE HYDRAULIC CONNECTIONS ARE PROPERLY CAPPED.

To install a new computer unit:

1. Ensure that all electrical power is turned off.
2. Install the new system chip supplied with the new computer. Do not use the system chip from the defective computer.
3. Mount the computer unit.
4. Reconnect all electrical connectors to the computer.
5. Reconnect hydraulic hoses to the computer (green is base-side and red is rod-side of the boom hoist cylinder).
6. Refer to the Calibration Manual for setup procedures.

# Reeling Drum

The reeling drum houses the reel-off cable to the boom tip, a cable from the reeling drum to the computer, and the boom angle sensor. The reeling drum provides the following signals that are sent directly to the computer via the reeling drum computer cable:

- o Boom Extension Signal – generated within the reeling drum, and controlled by the reel-off cable, as the boom is extended or retracted.
- o Boom Angle Signal – is generated within the reeling drum, and designed to measure the angle of the boom relative to the horizon.
- o Two-Block Signal – is transmitted to the boom head, through the reel off cable, to the reeling drum and signal cable to the computer. This is a voltage signal that has it's signal interrupted by the ATB Switch at the boom tip. When the two block switch open, the signal to the computer is interrupted, the display immediately displays a flashing light and an audible alarm on the operators display console, and the motion cutouts are activated.

## Reel-Off Cable

The reel-off cable (extension cable) extends from the reeling drum to the boom tip. The reel-off cable provides an electrical path for passage of the two-block warning signal from the boom tip to the computer cable in the reeling drum.

### Check Points

- o Carefully examine the reel-off cable for damage.
- o Fully telescope the boom in and out. As you extend or retract the boom, ensure that thereel-off cable is smoothly fed on and off the reeling drum without drooping along the boom or jumping, especially as the boom is telescoped in.

### **mWARNING**

THE REELING DRUM EXTENSION SETTING IS SET BY THE FACTORY. IF THE REEL-OFF CABLE HAS BEEN DAMAGED OR BROKEN DO NOT ATTEMPT TO REPAIR THE CABLE.

## Computer Cable

The reeling drum cable to the computer acts as a channel for passage of signals to the LMAP computer. Ensure that the cable exiting from the reeling drum, running down the boom, and around its pivot to the computer, is free from damage. If this cable has been damaged in any way, it should be carefully tested and may need to be replaced to ensure accurate transmission of signals.

## Slip Ring Assembly

The purpose of the slip-ring assembly is to provide an electrical path for the feed and switch signal return, between the ATB switch and the system computer.

It is unlikely that the slip-ring assembly should ever require repair or replacement. If such an event arises, however, both the upper and lower halves of the slip-ring assembly must be replaced at the same time.

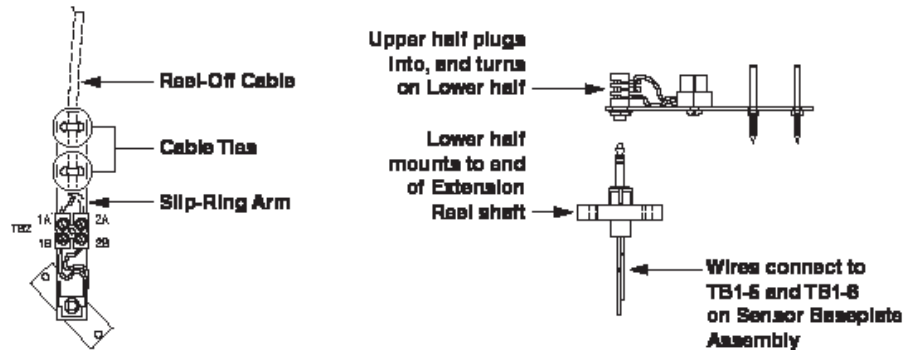

Failure of the slip-ring assembly will most likely result in a continuous ATB alarm. For information on testing and checking the slip-ring assembly, refer to the Anti-Two-Block on page 14.

With the ATB switch closed, the resistance should be less than 300 OHMS. If not, this suggests that the reel-off cable, ATB switch, or one of the boom head connectors has an Open circuit. Open the ATB switch at the boom head by lifting the weight. Measure the resistance between TB2-1 & TB2-2 terminal connections on the sensor arm.

With the ATB switch open, the resistance should be less than 200 ohms. If not, this suggests that the reel-off cable, ATB switch, or one of the boom head connectors has a short circuit.

## Sensor Baseplate Assembly

The sensor baseplate assembly supports both the extension and angle sensors and provides interconnection between the sensors, the ATB switch signal to the slip-ring, and the signal cable to the system computer.

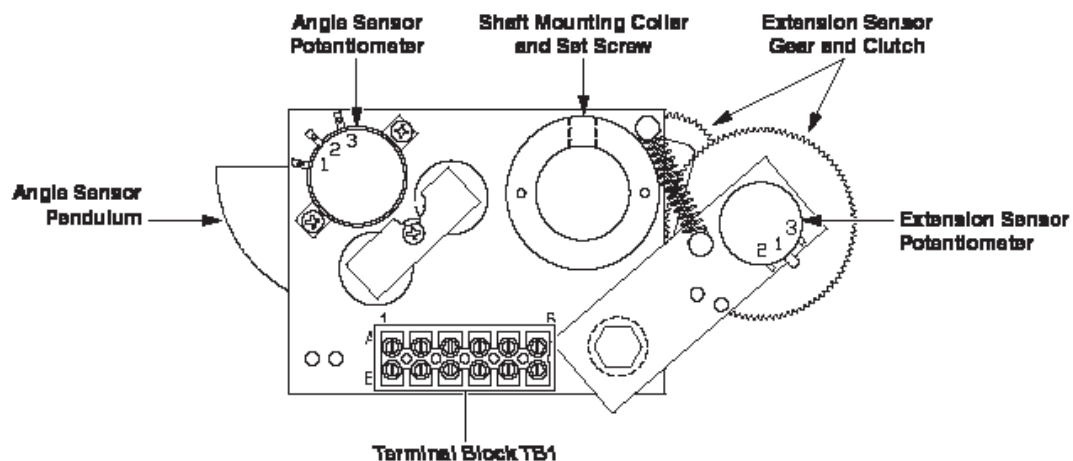



The terminal block (TB1), mounted on the assembly, provides wiring connection for all internal parts of the reeling drum, and the signal cable connecting the reel to the system computer. Most electrical diagnosis of the boom sensors may be made at this terminal block.

Signal voltages from the computer to the reeling drum may be accessed from the terminal strip on the sensor assembly inside the reel. The chart below shows minimum and maximum allowable voltages at each of these check points.

SIGNAL	BOOM POSITION / ACTION	VOLTAGE		VOLTMETER CONNECTION	
		MIN	MAX	RED(+)	BLACK (-)
Sensor Drive	—	4.7V	5.3V	TB1/4 - red	TB1/1 - blue
Angle Sensor Output	0 degrees	0.4V	0.6V	TB1/2 - green	TB1/1 - blue
Extension Sensor Output	0 ft. (0m) fully retracted	0.15V	0.35V	TB1/3 - white	TB1/1 - blue
Two-Block Drive	ATB Weight Down	5.5V	7.5V	TB1/6 - black	TB1/1 - blue
	ATB Weight Up	9.5V	10.5V	TB1/6 - black	TB1/1 - blue
Two-Block Signal	ATB Weight Down	5.5V	7.5V	TB1/5 - brown	TB1/1 - blue
	ATB Weight Up	0V	2V	TB1/5 - brown	TB1/1 - blue

### Diagnosis of load and radius errors as displayed on the display console

Load or radius errors may give rise to early or late tripping of overload alarms. Accuracy of load, radius, length, and angle is determined by the correct installation and maintenance of the system sensors.

- o Accuracy of load is governed by the radius accuracy, and the extension, angle, and pressure sensors.
- o Accuracy of radius (unloaded) is governed by the extension and angle sensors.
- o Before continuing, make sure that there are no system faults.

## Reeling Drum Troubleshooting Table

Condition	Action
Angle displays “---” or is reading erratically	<ul style="list-style-type: none"> <li>With the boom at zero degrees measure voltage drive voltage in the reeling drum. If it does not match the voltage table test power at the computer connections.</li> <li>Test angle sensor output voltage with the boom level and then rotate the pendulum counterclockwise to watch the voltage increase. If the starting voltage does not match the table, adjust the sensor. If the voltage is erratic when moving the pendulum, change the sensor.</li> </ul>
Length displays “---” or is reading erratically	<ul style="list-style-type: none"> <li>Measure drive voltage in the reeling drum. If it does not match the voltage table test power at the computer connections.</li> <li>With the boom fully retracted test the extension sensor output voltage and after pulling the extension sensor arm away from the gear move the pot counterclockwise while watching the voltage increase. If the starting voltage does not match the table, adjust the sensor. If the voltage is erratic while moving the sensor, replace the length pot.</li> </ul>
Length, angle, and radius all display “---” or are reading erratically	<ul style="list-style-type: none"> <li>Test continuity of reel cable and connectors. Test for drive voltage going to your reel base plate.</li> </ul>
Load is reading heavy or light	<ul style="list-style-type: none"> <li>Measure radius and compare it to the display. If it is more than .5 ft off recalibrate your length and angle.</li> </ul>
Capacity does not display correct value	<ul style="list-style-type: none"> <li>Check your crane set up to make sure your configuration matches your crane. Measure your radius and compare it with the display. If it is more than .5 ft off recalibrate your length and angle. Make sure your duty chip matches the crane model.</li> </ul>

SIGNAL	BOOM POSITION / ACTION	VOLTAGE		VOLTMETER CONNECTION	
		MIN	MAX	RED(+)	BLACK (-)
Sensor Drive	—	4.7V	5.3V	TB1/4 - red	TB1/1 - blue
Angle Sensor Output	0 degrees	0.4V	0.6V	TB1/2 - green	TB1/1 - blue
Extension Sensor Output	0 ft. (0m) fully retracted	0.15V	0.35V	TB1/3 - white	TB1/1 - blue
Two-Block Drive	ATB Weight Down	5.5V	7.5V	TB1/6 - black	TB1/1 - blue
	ATB Weight Up	9.5V	10.5V	TB1/6 - black	TB1/1 - blue
Two-Block Signal	ATB Weight Down	5.5V	7.5V	TB1/5 - brown	TB1/1 - blue
	ATB Weight Up	0V	2V	TB1/5 - brown	TB1/1 - blue

# Anti-Two Block

## mWARNING

WHEN PERFORMING THIS TEST, TURN THE CRANE POWER OFF AND THEN ON AGAIN TO ENSURE THAT AN EXISTING TWO-BLOCK WARNING AND/OR MOTION CUT HAS NOT BEEN OVERRIDDEN.

DURING PERFORMANCE OF THIS TEST, DO NOT USE THE CANCEL ALARM BUTTON TO CLEAR AUDIBLE WARNINGS OR MOTION CUTS.

DURING PERFORMANCE OF THIS TEST, DO NOT WINCH THE HOOK BLOCK INTO THE BOOM TIP, IN CASE THE SYSTEM DOES NOT CUT THE CRANE MOTIONS.

## The Anti-Two-Block Weight

### Check Points

- o Ensure that the anti-two-block weight and its parts are undamaged, in proper position, and correctly connected.
- o Check the chain on the anti-two-block weight for damage and stress, ensuring that there are no open links in the chain.
- o Ensure that the chain is securely attached with screw pin and shackle to the narrow vertical connector projecting from the base of the anti-two-block switch.
- o Ensure that the anti-two-block weight has been installed around one part of the load line.

## The Anti-Two-Block Switch

### Checkpoints

- o Ensure that the anti-two-block switch is secure on its mounting post with safety pin inserted through the end of the mounting post and locked into position.
- o Ensure that the switch cable is secured to the strain relief thimble and that the thimble is on the mounting post behind the switch.
- o Ensure that all electrical cables and connectors are free from damage and correctly connected.

## Checking the Two-Block Warning Signals and Cutout of Machine Motions

The following test activates the anti-two-block warning signals and the valve controlling cut out of crane motions to ensure proper operation. No other pre-existing alarm conditions may be active when performing this test.

1. Slowly raise the hook block until it lifts the anti-two-block weight and deactivates the anti-two-block switch.

NOTE: This action should cut out the winch up motion as well as the boom down, and boom extend motions. Audible and visual alarms on the operator's display console should become active.

2. Lower the hook block by winching down.

NOTE: This action should remove the audible and visual alarms on the operator's display console and reactivate the boom motions.

## ATB Troubleshooting Table

<p>PROBLEM: The ATB alarm is continuously ON and operating the switch at the boom head does not deactivate the alarm.</p> <p>This problem suggests an open circuit between the computer ATB input and the ATB switch(es), or an open circuit between the computer ATB feed and the ATB switch(es)</p>	<ol style="list-style-type: none"> <li>1. Check extension reel-off cable for damage.</li> <li>2. Make sure that the Two-Block switches are correctly connected.</li> <li>3. Check the slip-ring and wiring inside the reeling drum.</li> <li>4. Check the signal cable from the reeling drum to the computer. Check connectors.</li> </ol>
<p>PROBLEM: The ATB alarm is continuously operating in the OFF (or safe mode).</p> <p>The system does not activate by lifting the ATB weight does not activate the alarm.</p> <p>This problem suggests a short circuit between the computer ATB input and the computer ATB feed somewhere between the computer and the ATB switch(es).</p>	<ol style="list-style-type: none"> <li>1. Check extension reel-off cable for damage.</li> <li>2. Make sure that the ATB switches are correctly connected.</li> <li>3. Check the slip-ring and wiring inside the reeling drum.</li> <li>4. Check the signal cable from the reel to the computer. Check connectors.</li> </ol>

### Checking The ATB Circuit

Before continuing, ensure that connectors are correctly connected to the ATB switches at the boom head/jib. Use a bent paper clip or a piece of wire (at least two inches long) with the wire exposed on either end to jump the circuit. Refer to the diagram on the following page for locations corresponding to the steps below.

1. ATB Cable – Disconnect the ATB cable from the ATB switch. Place the jumper onto male connector position 1 and 2 of the ATB cable. If the condition stops, replace the ATB switch. If the condition persists, continue to step 2.
2. Extension Reel Cable – Disconnect the ATB cable from the extension reel cable. Place the jumper into female connector position 1 and 2 of the extension reel cable. If the condition stops, replace the ATB cable. If the condition persists, continue to Step 3.
3. ATB Sensor Arm Terminal Block– Remove the extension reel cover. Do not disconnect the ATB sensor arm. Place the jumper onto ATB sensor arm terminal block position TB2-1B and TB2-2B. If the condition stops, replace the extension reel cable. If the condition persists, continue to Step 4.
4. Sensor Baseplate Terminal Block - With the extension reel cover still removed, disconnect the ATB sensor arm from the plug. Place the jumper onto the sensor baseplate terminal block position TB1-5A and TB1-6A. If the condition stops, replace the slip ring assembly. If the condition persists, continue to Step 5.
5. Extension Reel Cable to Computer – Disconnect the extension reel cable from the computer cable. Place the jumper into female connector position A and D of the computer cable. If the condition stops, replace the extension reel cable to computer. If the condition persists, continue to Step 6.
6. Computer Terminal Block JP8 – Remove the computer cover. Place the jumper into terminal block position JP8-1 and JP8-4. If the condition stops, replace the computer cable. If the condition persists, replace the computer.

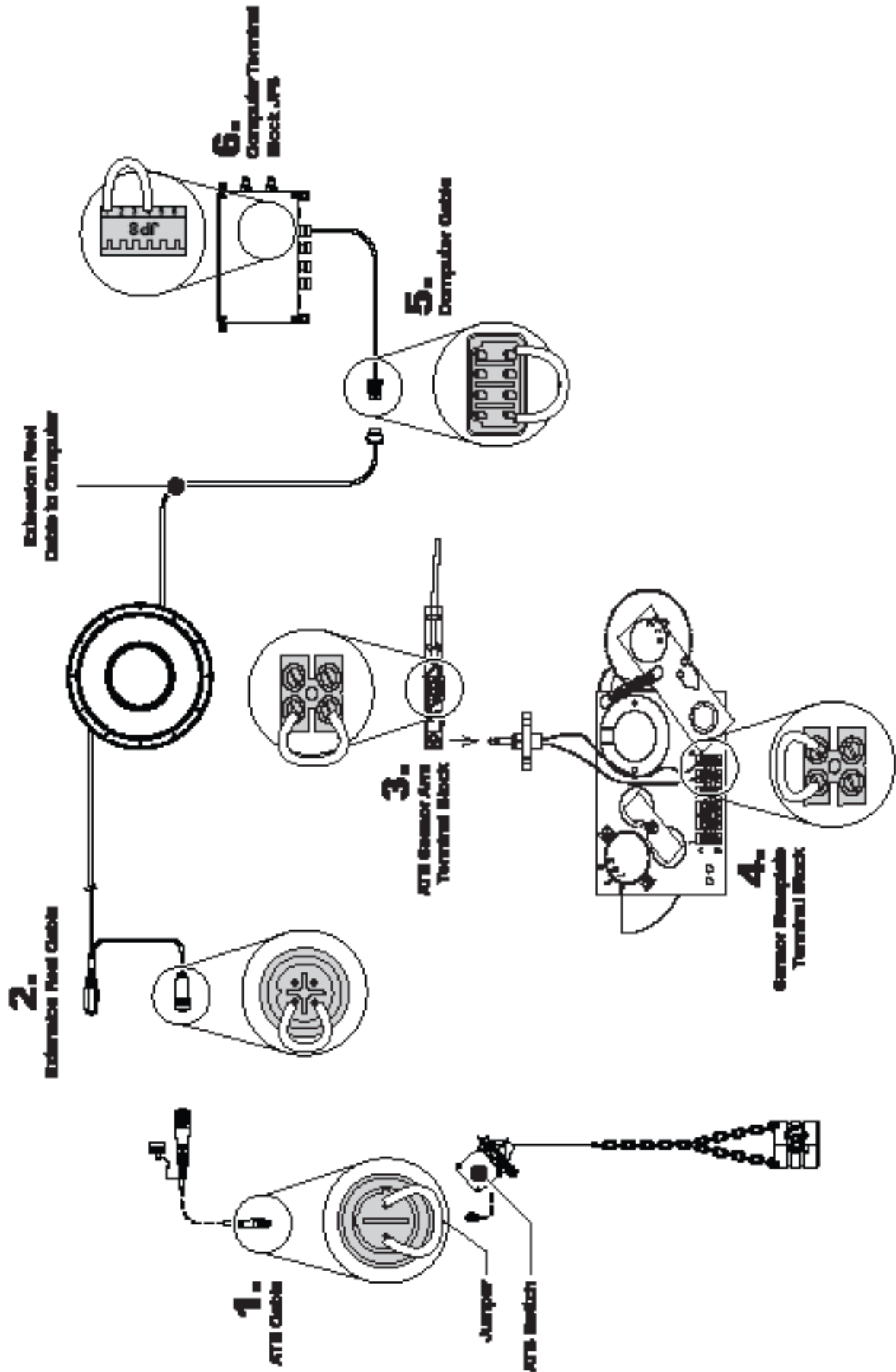

# Swing

The swing potentiometer measures the angle of the upper structure of the crane relative to its carrier. This angle is then used to select working area alarms. The swing sensor is mounted on the under side of the hydraulic swivel on the unit and is a sealed unit.

The swing potentiometer must be properly calibrated so that zero degrees is located in the rest, and when the unit is rotated clockwise, the measurement should increase in one degree increments until the unit has been rotated 360 degrees. Then the unit will go back to zero degrees and start all over again. To verify proper calibration of the potentiometer, refer to the Calibration Manual.

The computer produces a 4.7 V signal at JP11-1 that is connected to the swing potentiometer on its positive terminal. JP11-2 is then connected to the ground terminal on the swing potentiometer. JP11-3&4. These lines are connected to the swing potentiometer A & B communication lines and the resulting signals are processed into a counter for 360 degrees.

In some cases, it may be necessary to disable the swing potentiometer. For example, if the swing potentiometer is malfunctioning, it can be disabled or "removed" from the system, essentially disconnected so that the computer does not receive false readings.

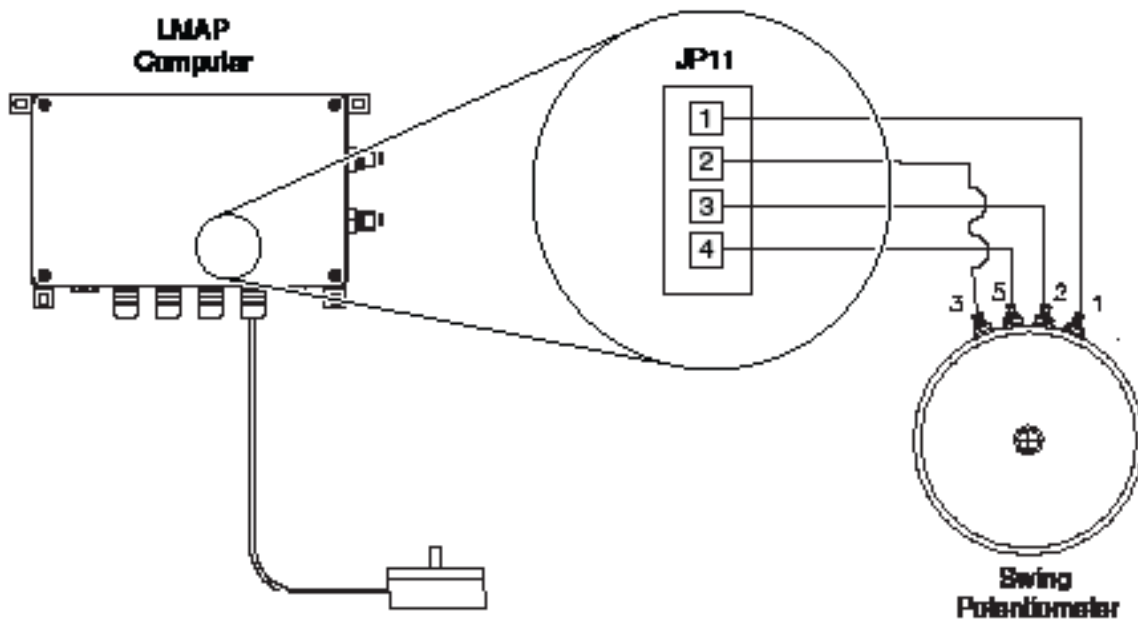

JP11-1 (Positive Drive)
JP11-2 (Negative Drive)
JP11-3 (Swing Signal "A")
JP11-4 (Swing Signal "B")

## Disabling the Swing Potentiometer

In some cases, it may be necessary to disable the swing potentiometer. For example, if the swing potentiometer is malfunctioning, it can be disabled or “removed” from the system, essentially disconnected so that the computer does not receive false readings.

### mWARNING

REMOVING THE SWING POTENTIOMETER IS A TEMPORARY SOLUTION AND WILL DISABLE ANY SWING OR WORKING AREA ALARMS.

1. While in menu “04 Swing Potentiometer”, press the key adjacent to either “Menu Up” or “Menu Down” until “Remove Swingpot?” appears in the information window at the right.
2. Press the key adjacent to “Remove Swingpot?”.



3. The computer will ask you to confirm the choice. Press the key adjacent to “yes” to proceed, or press the key adjacent to “No” to cancel. Press the key adjacent to “Exit” to return to the sub-menu.

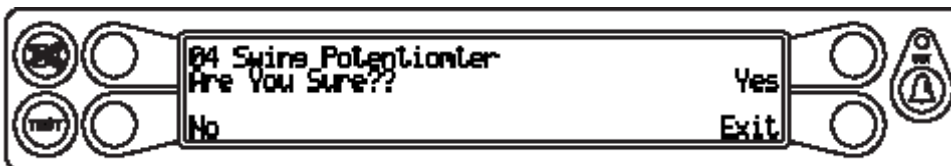

4. The information window will show “Swing Pot Removed” at the right.

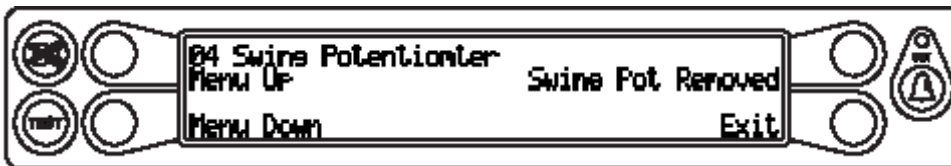

When you have finished, press the key adjacent to “Exit” to return to the main menu.

## Enabling the Swing Potentiometer

1. While in menu “04 Swing Potentiometer”, press the key adjacent to either “Menu Up” or “Menu Down” until “Zero =----” appears in the information window at the right.
2. Press the key adjacent to “Zero =----”.



3. The swing potentiometer is now enabled, refer to “Zeroing the Swing Potentiometer” on page 8 of the Calibration Manual to set the proper zero point for the boom.

When you have finished, press the key adjacent to “Exit” to return to the main menu.

# Error Codes

## Fault Reporting And Fault Codes

System fault codes provide one of the most important ways to quickly locate and assess problems in the LMAP System. Please review this section carefully.

Each time the system is turned on, it goes through a self-testing process lasting six to eight seconds that automatically detects most faults in the system.

During normal operation, a self-test can be initiated at any time by pressing the TEST key on the display console. Many fault conditions are detected without a system self-test. Faults detected in the system during the self-test, are indicated on the display console in the following ways:

- o The red overload lamp will illuminate.
- o An audible alarm will sound.
- o "WARNING SYSTEM FAULT!" or "SYSTEM OUT OF SERVICE" will be displayed at the bottom of the information window.

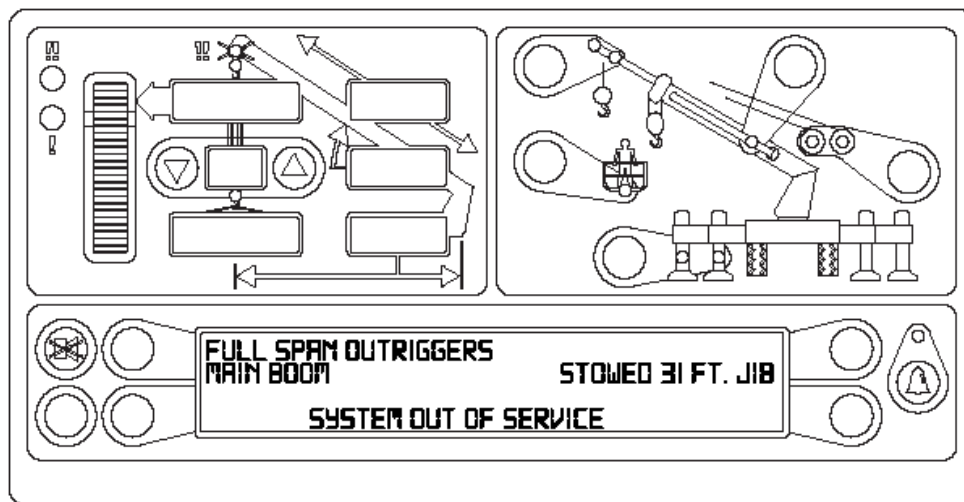

To view specific error codes, it is necessary to go into calibration mode.

### mWARNING

WHEN THE SYSTEM IS IN CALIBRATION MODE, AUTOMATIC OVERLOAD CONTROLS ARE DISABLED. THE CRANE OPERATOR IS RESPONSIBLE FOR PROPER LOADING OF THE CRANE WHILE PERFORMING CALIBRATION.

To access calibration mode:

1. Hold down the TEST and SET keys simultaneously. The audible alarm will sound and you will be prompted to enter the security key code.

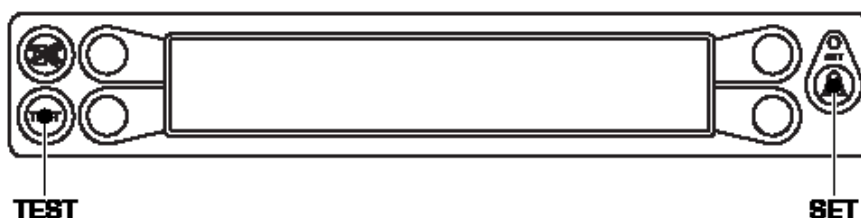



2. Enter the security code in order (1, 2, 3, 4) as shown.



The computer will execute a brief self test and display the calibration menu.

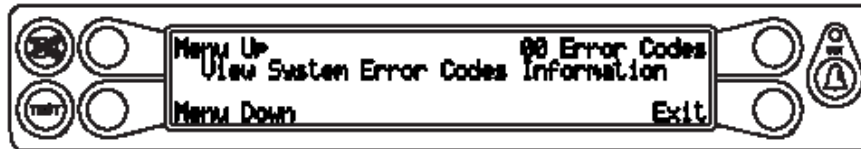

Press the key adjacent to "00 Error Codes".

The following information is displayed:

1. System error codes
2. Computer serial number (should match the number on the label on the enclosure)

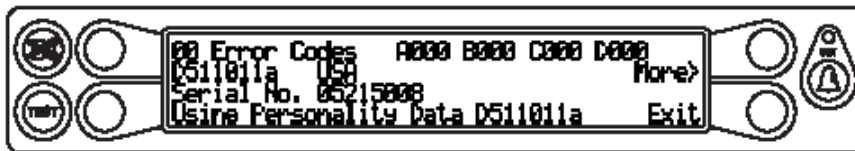

Press the key adjacent to "More" to view additional system information. The following information is displayed:

1. Crane specific file codes

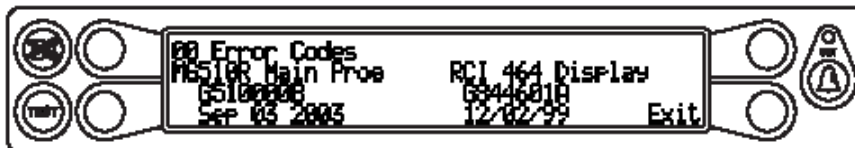

When you have finished, press the key adjacent to "Exit" to leave the routine.

NOTE: Check and repair "B" and "C" group faults before proceeding with group "A" sensor faults.

## Group "A" Fault Codes

Group "A" fault codes represent faults detected for analog sensors.

Fault Code	Swing Sensor	Boom Angle Sensor	Extension Sensor	Tdx 1 Rod Pressure	Tdx 0 Piston Pressure	Action
000	No Fault Found					None
001					X	Check functionality of load sensors. If the transducers read incorrectly, replace computer (refer to "Computer Replacement" on page 9).
002				X		
003				X	X	
004			X			Check extension sensor (refer to "Sensor Baseplate Assembly" on page 11).
005			X		X	Check functionality of load sensors. If the transducers read incorrectly, replace computer.
006			X	X		
007			X	X	X	
008		X				Check boom angle sensor (refer to "Sensor Baseplate Assembly" on page 11).
009		X			X	Check functionality of load sensors. If the transducers read incorrectly, replace computer (refer to "Computer Replacement" on page 9).
010		X		X		
011		X	X	X		
012		X	X			Check boom extension/angle sensor (refer to "Sensor Baseplate Assembly" on page 11).
013		X	X		X	Check functionality of load sensors. If the transducers read incorrectly, replace computer (refer to "Computer Replacement" on page 9).
014		X	X	X		
015		X	X	X	X	
016	X					Check swing potentiometer (refer to "Swing" on page 17).
017	X				X	Check functionality of load sensors. If the transducers read incorrectly, replace computer (refer to "Computer Replacement" on page 9).
018	X			X		
019	X			X	X	
020	X		X			Check extension and swing sensors (refer to "Sensor Baseplate Assembly" on page 11, and "Swing" on page 17).
021	X		X		X	Check functionality of load sensors. If the transducers read incorrectly, replace computer (refer to "Computer Replacement" on page 9).
022	X		X	X		
023	X		X	X	X	
024	X	X				Check swing potentiometer/boom angle (refer to "Sensor Baseplate Assembly" on page 11, and "Swing" on page 17).

Fault Code	Swing Sensor	Boom Angle Sensor	Extension Sensor	Tdx 1 Rod Pressure	Tdx 0 Piston Pressure	Action
025	X	X			X	Check functionality of load sensors. If the transducers read incorrectly, replace computer (refer to "Computer Replacement" on page 9).
026	X	X		X		
027	X	X		X	X	
028	X	X	X			Check swing, angle, and extension sensors (refer to "Sensor Baseplate Assembly" on page 11, and "Swing" on page 17).
029	X	X	X		X	Check functionality of load sensors. If the transducers read incorrectly, replace computer (refer to "Computer Replacement" on page 9).
030	X	X	X	X		
031	X	X	X	X	X	Check functionality of load sensors. If the transducers read incorrectly, replace computer (refer to "Computer Replacement" on page 9).
032 or higher	Internal Temperature Sensor Fault. Replace Computer (refer to "Computer Replacement" on page 9).					

### Group "B" Fault Codes

Group "B" fault codes represent faults detected for internal analog functions and power feeds to the function kickout and anti-two block switches.

Fault Code	FKO Power Feed	ATB Power Feed	Display Console	ADC 2 Internal Fault	ADC 1 Internal Fault	Action
000	No Fault Found					None
001					X	Test power coming into the computer. If constant 12V, reset the computer at least twice. If code is still present, replace the computer (refer to "Computer Replacement" on page 9).
002				X		
003				X	X	
004			X			Replace display console.
005			X		X	Test power coming into the computer. If constant 12V, reset the computer at least twice. If code is still present, replace the computer (refer to "Computer Replacement" on page 9).
006			X	X		
007			X	X	X	
008		X				

Fault Code	FKO Power Feed	ATB Power Feed	Display Console	ADC 2 Internal Fault	ADC 1 Internal Fault	Action
009		X			X	Test power coming into the computer. If constant 12V, reset the computer at least twice. If code is still present, replace the computer (refer to "Computer Replacement" on page 9).
010		X		X		
011		X		X	X	
012		X	X			
013		X	X		X	
014		X	X	X		
015		X	X	X	X	
016	X					Test internal FKO fuse.
017	X				X	Test internal FKO fuse. Test power coming into the computer. If constant 12V, reset the computer at least twice. If code is still present, replace the computer (refer to "Computer Replacement" on page 9).
018	X			X		
019	X			X	X	
020	X		X			
021	X		X		X	
022	X		X	X		
023	X		X	X	X	
024	X	X				Test internal FKO fuse.
025	X	X			X	Test internal FKO fuse. Test power coming into the computer. If constant 12V, reset the computer at least twice. If code is still present, replace the computer (refer to "Computer Replacement" on page 9).
026	X	X		X		
027	X	X		X	X	
028	X	X	X			
029	X	X	X		X	
030	X	X	X	X		
031	X	X	X	X	X	

## Group "C" Fault Codes

Group "C" fault codes represent faults detected for internal computer memories.

Fault Code	Serial EEPROM	Crane Data	RAM	Duty Data	Program	Action
000	No Fault Found					None
001					X	Replace system chip then, reset and erase crane data.
002				X		
003				X	X	
004			X			Test power coming into the computer. If constant 12V, reset the computer at least twice. If code is still present, replace the computer (refer to "Computer Replacement" on page 9).
005			X		X	Replace system chip then, reset and erase crane data.
006			X	X		
007			X	X	X	
008		X				Reset and erase crane data.
009		X			X	Replace system chip then, reset and erase crane data.
010		X		X		
011		X	X	X		
012		X	X			Test power coming into the computer. If constant 12V, reset the computer at least twice. If code is still present, replace the computer (refer to "Computer Replacement" on page 9).
013		X	X		X	Replace system chip then, reset and erase crane data.
014		X	X	X		
015		X	X	X	X	
016	X					Reset and erase crane data, then reselect crane setup/configuration. Replace computer if not resolved.
017	X				X	Replace system chip then, reset and erase crane data.
018	X			X		
019	X			X	X	
020	X		X			Test power coming into the computer. If constant 12V, reset the computer at least twice. If code is still present, replace the computer (refer to "Computer Replacement" on page 9).
021	X		X		X	Replace system chip then, reset and erase crane data.
022	X		X	X		
023	X		X	X	X	

Fault Code	Serial EEPROM	Crane Data	RAM	Duty Data	Program	Action
024	X	X				Reselect crane setup/configuration. Reset crane data. Otherwise, replace computer if not resolved.
025	X	X			X	Replace system chip then, reset and erase crane data.
026	X	X		X		
027	X	X		X	X	
028	X	X	X			Test power coming into the computer. If constant 12V, reset the computer at least twice. If code is still present, replace the computer (refer to "Computer Replacement" on page 9).
029	X	X	X		X	
030	X	X	X	X		
031	X	X	X	X	X	

### Group "D" Fault Codes

Group "D" fault codes represent faults detected for capacity chart selection.

Fault Code	Wrong Swing Area	Wrong Boom Length	Chart Not Found	Action
000	No Fault Found			None
001			X	Check other sensor faults. Reselect crane setup.
002		X		Boom length is out of range for selected chart. Check crane setup, boom length, and boom extension.
003		X	X	Check other sensor faults. Reselect crane setup.