



Installation Manual
&
Operating Instructions

Model 210

Table of Contents

| | |
|---|--------------|
| Packing list | 3 |
| Specifications | 4 |
| Prior to installation of Sigalarm, Grounding notes | 5 |
| Installation & Function notes | 6-7 |
| Additional wiring options | 8 |
| Cable Reel Drawing | 9 |
| Electrical schematic | 10 |
| Pigtail assembly diagram | 11 |
| Bracket Installation diagram | 12 |
| Trouble shooting | 13 |
| Operation Introduction | 14 |
| Dual Function notes, Warning notes | 15 |
| Front panel familiarity & identification | 16-17 |
| Operating procedures | 18-20 |

Information furnished by Allied Safety Systems in this document is believed to be accurate. Allied Safety Systems makes no warranty, express, statutory and implied or by description, regarding the information set forth herein. Allied Safety Systems reserves the right to change specifications at any time and without notice.

Allied Safety Systems Products are intended for use in normal commercial and industrial applications. Applications requiring extended temperature range or unusual environmental requirements such as military, medical life support or life sustaining equipment are specifically not recommended without additional testing for such applications.

Allied Safety Systems reserves the right to make periodic modifications of this product without obligation to notify any person or entity of such revision. Copying, duplicating, selling, or otherwise distributing any part of this manual without the prior written consent of an authorized representative of Allied Safety Systems is prohibited.

Copyright 2012

Sigalarm Packing List: 210

| Part # | Quantity | Description | Included |
|---|----------|--|----------|
| 7001 | 1 | Control Module | |
| 9004 | 1 | Knob Cover | |
| 7112-C | 1 | 2-Pin Connector | |
| 7111-C | 1 | 6-Pin Connector | |
| 7111-H | 1 | Horn | |
| manual | 1 | Manual | |
| 9103 | 2 | 7" Brackets | |
| 9108 | 3 | 2" V Brackets | |
| 7115-6 7900 54010-1 206153-1 A1340-ND | 1 | Pigtail w connectors 2- 6' of antenna 1- AMP shrink tube connector 1- Male connector 4- Male Pins | |
| 7315 54010-1 206060-1 A31988 00Z521 10-103 69100 196613 192479 1131823 | 1 | Parts bag 1- AMP shrink tube connector 1- AMP 4 pin plug female connector 2- AMP female socket (pins) 1- 6" Kester solder 2- Orange wire nuts 1- 3'8" Clear tube 1- 1/2" black shrink 1- 3/16" black shrink 4- Drill & Tap 14 x 1 screws | |
| 1170710 | 6 | Bolt w/nut 1/4"-20 SS FHN | |
| 2412-12 | 1 | 24-12 Volt converter (optional) | |
| 101725 | 1 | 34/51 m metal cable reel kit 3-2.5" square roller guides 1- 3.5" guide 4-10.5" brackets 51m of cable | |
| Cable reel | 1 | Reel sizes vary | |

Specifications

Power requirements

- input voltage- +11 to +15 VDC
- input current-
Standby-200 ma DC max
Operating-4amps DC peak

Operating temperature

- -29F to +158F

Alarm outputs:

- Visual- by means of a flashing red light mounted on the control module.
Repetition rate: proportional to electric field intensity at the sensor cable, up to a maximum of 5 alarms per second
- Audible-internal buzzer
- Audible-external horn
Repetition rate: proportional to electric field intensity at the sensor cable, up to a maximum of 5 alarms per second

Sensing

- Electric field, 60Hz or overseas 50Hz

Sensitivity adjustment

- Front panel controls provide means for coarse and fine adjustment of the Sigalarm systems sensitivity. The coarse control adjusts the sensitivity by 1.0,10, 100, 1000, 10,000, and 100,000. The fine control adjusts the sensitivity within each range set by the coarse control, providing a means of continuous adjustment of sensitivity from zero to the maximum sensitivity set by the coarse control.

Size

- 8" X 7.55" X 4"

Range of effectiveness:

- Depending upon the proximity of the overhead high voltage line, and its intensity, Sigalarm systems can be adjusted to actuate the warning alarm at any desired plane from 20feet (OSHA minimum) to 200 feet.

Range limiting ability:

- Available on every unit through auto shut down wiring options

Prior to installation of Sigalarm

The Sigalarm system is designed to protect the entire boom, and has a circuit in the control module to test all system components including the antenna and the electronics controls. This is accomplished by depressing the test button on the control module for approximately three seconds. This action applies 12 volts dc to the entire antenna to insure there are no breaks. Understanding the above makes it easier to install the system. Note: Antenna leads use a minimum of 22 gauge wire since this is a very low current application. (Less than 2 ma for however long the test button is depressed.)

Grounding

- Measure the ohm value of the ground cable used to ground the negative terminal of the battery to the chassis. The cable should be less than one ohm.
- Measure the ohm value from the negative terminal of the battery to chassis. This measurement should be made to the chassis in the front of the vehicle near the battery to the rear of the vehicle. This reading should be approximately the ohm value of the cable above.
- The power supply to Sigalarm must be plus 11 to plus 15 volts DC. Note: the voltage that is supplied to Sigalarm should be verified by measuring the plus supply voltage to the chassis of the vehicle. If the voltage is less than the battery that supplies the voltage then the battery to negative terminal to chassis should be checked.

Mounting of the reel, cable guides, and brackets

- Use silicone where necessary to keep water out of reel.
- Use a properly sized reel for equipment. Do not over extend the spring or damage may occur.
- When installation is complete extended the boom to check mechanical operation. The antenna sensor should be able to freely slide through the guides.

Installation & Function notes

Range Control:

Proper installation and operation of this system will allow persons engaging in construction activities to have sufficient warning of encroachment on a pre-determined (by the operator) plane. This system will warn operators and ground crew of plane encroachments with audible and visual alerts.

Range limit:

Installation of the auto shut down feature will allow persons to limit the equipment's range of motion
** Auto shut down installation is not recommended for cranes moving a load**

Control Module (7001):

The main component of your Sigalarm system is the control module. It should be mounted at the operator's work station. This control module incorporates a built-in warning horn, red warning light, green power/antenna condition indicator light, and the sensitivity knobs. Refer to Front panel familiarity diagram for more specific details.

Placement

Mount the control module so that the operator can easily reach and adjust the controls from his normal operating position without obstructing the field of vision. The control module must be grounded to the chassis from this position.

Grounding:

The control module must be grounded to the chassis of the equipment, remove excess paint and tighten screws if necessary.

Lead in (2 pin) (7112-c):

Forty feet of shielded lead-in is supplied to be installed between the control module inside the cab, to the cable reel where the active antenna sensor begins. This lead-in is shielded electronically and will **not sense voltage. This lead in cable will connect your control module to your cable reel. Fasten the end of this cable to the control module. Rout the cable through the cab to the cable reel. Refer to the electrical schematic and cable reel drawing for more specific details**

white wire to #9 reel block terminal (red coax)
black wire to #10 reel block terminal (brown shield)

Cable Reel (101725):

A cable reel with 34m spring and 51m length of antenna cable will be provided. If using a reel other than one supplied by Sigalarm refer to additional wiring options for more specific details. The antenna on the reel will be securely fixed near the end of the boom using a 10" bracket and a V bracket, and then connect the pigtail (7115-6) at the tip of the boom with an amp quick disconnect connector. Refer to cable reel drawing for more specific details

Placement

- Mount the reel and cable guides without violating the structural integrity of the equipment. The brackets and hardware furnished should be adequate for most installations.
- Verify that the antenna sensor will have an unobstructed straight line between the reel and guides. (It is recommended that the first cable guide be 4-5 feet in front of reel and 4-5 inches below where antenna releases off reel in order to supply proper tension).
- Install antenna sensor 2-7 inches off the solid metal boom. (Keep in mind that some boom shielding might occur and sensitivity adjustments may need to be made)

Install amp connecter

- Slide heat shrink over cable for later use

- Remove approximately ¾” of the external black jacket (be extremely careful not to cut shield) #16 AWG of crimp tool is recommended
- Peel back shield and twist shield back together to form 2nd wire
- Crimp female socket (a31988) to shield
- Cut ¼” clear coating off coax cable leaving just enough exposed wire to crimp on female socket (a31988)
- Use electrical tape to build up cable end at connector prior to attaching heat shrink
 - Shield to pin 1
 - Coax to pin 3

Connect this length of antenna cable to the pigtail using the amp connectors provided

Note that the length of fixed cable between the reel and tip of the retracted boom does not factor into the spring tension calculations.

Antenna (7900) (7115-6)

The unshielded antenna cable detects the presence of voltage. On telescoping booms a single antenna cable will be mounted from the cable reel to the tip of the boom. At the tip of the boom the antenna cable will connect to a split antenna assembly called a "pigtail" (7115-6). Refer to Sigalarm Cable Reel Drawing for morespecificdetails.

(7115-6)

A split antenna assembly called a "pigtail" (7115-6) will be installed at the tip of the boom. The split cables will be mounted to either side of the boom or ladder. Use the (9103) 7” and (9108) 2” v- brackets provided to mount the cables. Refer to **pigtail diagram** for more specific instructions.

External horn (7111-h):

An exterior horn (110 decibels 4amp draw) is included with each system to warn persons outside the cab of planeencroachment.

Battery Cables (6pin) (7111-c):

A forty foot cable assembly with three cables, grey (power input), white (external horn) and black (optional auto shut-down), is provided. This system is designed for 12 volt power supply. Install a power converter if 12 volts is not available. Connect the cables as follows.

Grey cable to power

- Black wire to 12v (negative/ground)
- Red wire to 12v (positive)

White cable to external horn

****Do not shorten this cable****

- Red wire to yellow/horn
- Black wire to white/horn

Black cable to “Auto shut down” (Optional)

The Auto shut down feature is optional; if you intend to use this feature install the cables as follows, if not you may remove the length of cable or coil and store for later use.

- Black wire to hydraulic/e-stop**refer to schematic**
- White wire to hydraulic/ e-stop**refer to schematic**

Prior to operation -Use the hold to test button on the control panel to verify that the entire system is workingcorrectly.

Additional Wiring options

Sigalarm will supply the entire antenna system for models: 110, 210, 310, and 510; however the following are additional wiring options that may be utilized to connect antenna lead in with antenna pigtail:

- This includes coaxial cables, single or double wire shielded cables, or two single unshielded cables.
- If a single coaxial cable is utilized, the shield may be utilized as one of the two leads that is required in order to test the antenna system. The shield must go to the black wire of antenna lead in.
- If a single wire shielded cable or two wire coaxial is utilized, the shield may be utilized as one of the two leads that is required to test the antenna system. The shield provides an excellent electrostatic field detector. The shield must go to black wire of antenna lead in.
- If a double wire shielded cable is utilized, the shield must be utilized as one of the two wires that is required to test the system. If the two center wires are used, one of the wires must be connected to the shield where it connects to the pigtails at the top of the boom. The shield must go to black wire of antenna lead in.
- If two unshielded wires are available they may be utilized and can be installed as a standard hookup.

If AC is used anywhere on vehicle, the Sigalarm unit might detect this field and alarm depending on the set sensitivity. If this happens, it is recommended to use a shielded antenna wire near AC source. Please note that now the “active” part of the antenna is only the non shielded portion and not the entire length of antenna.

| | |
|----------|--|
| REVISION | |
| | |

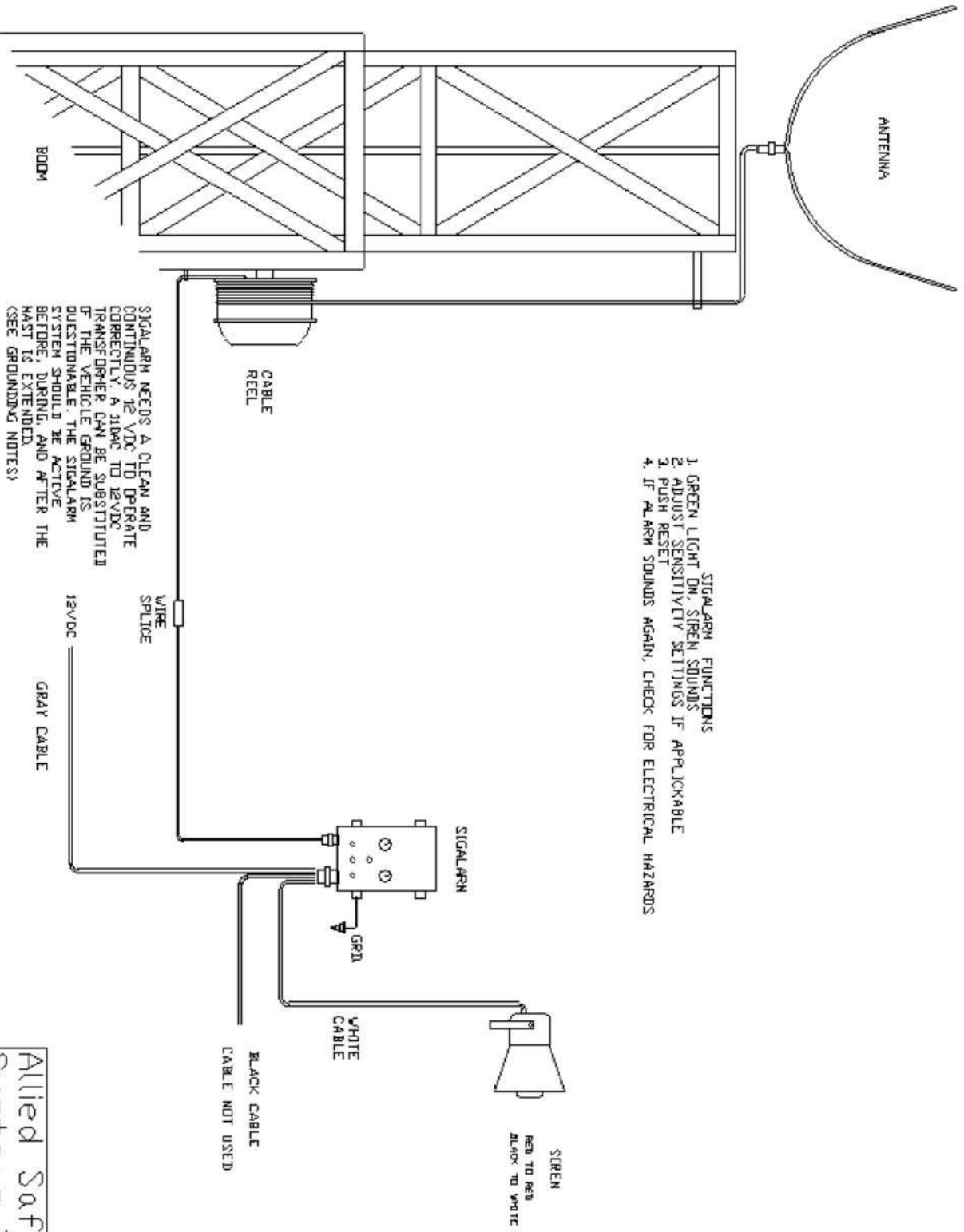

- SIGNALARM FUNCTIONS
1. GREEN LIGHT ON, SIREN SOUNDS
 2. ADJUST SENSITIVITY SETTINGS IF APPLICABLE
 3. PUSH RESET
 4. IF ALARM SOUNDS AGAIN, CHECK FOR ELECTRICAL HAZARDS

SIGNALARM NEEDS A CLEAN AND CONTINUOUS 12VDC TO OPERATE CORRECTLY. A 10AMP TO 12VDC TRANSFORMER CAN BE SUBSTITUTED IF THE VEHICLE GROUND IS QUESTIONABLE. THE SIGNALARM SYSTEM SHOULD BE ACTIVE BEFORE, DURING, AND AFTER THE HAST IS EXTENDED. (SEE GROUNDING NOTES)

| | |
|------------------------------|--------------|
| Allied Safety Systems Inc. | |
| TITLE: Sigalarm Installation | |
| DATE: 3-1-06 | PAGE: 1 OF 1 |
| DRAWN BY: J. Brown | |

Electrical Schematic

| REVISIONS | | |
|-----------|--------------------|---------------|
| REV | DESCRIPTION | DATE/APPROVED |
| A | SW2 WIRING DETAILS | 1-5-98 JDM |

(NOTE)
 WHEN USING AUTO SHUTDOWN IT IS RECOMMENDED THAT A 15 AMP IN-LINE FUSE BE UTILIZED TO PROTECT RELAY RY4 FROM BEING DAMAGED THE FUSE CAN BE INSTALLED IN EITHER PIN (F) OR (D).

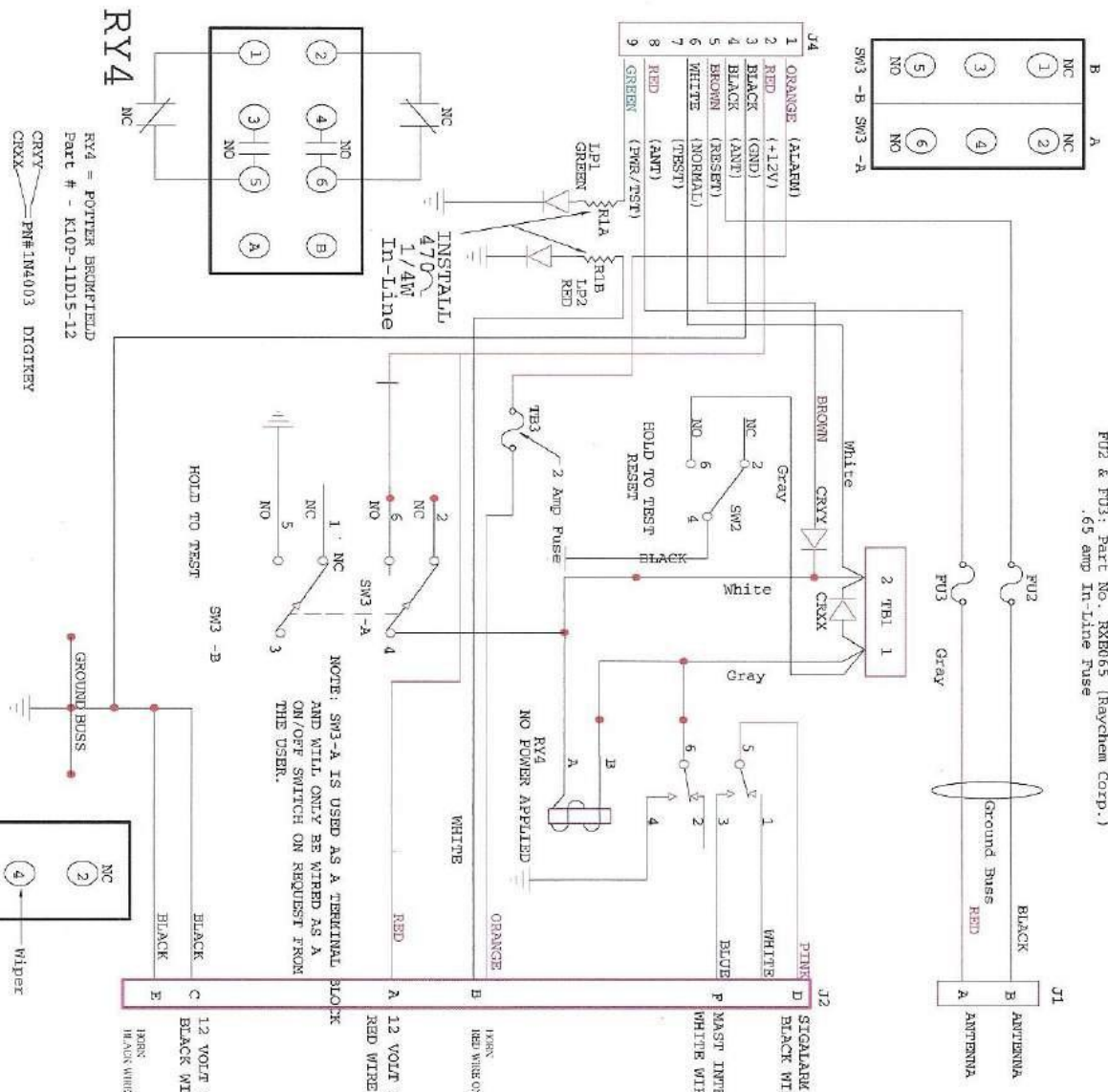

Specifications:
 15 AMP Closed circuit between pin D and F when the following requirements are satisfied
 A: = 12 volts applied to Signalarm
 B: = No Alarm / after system has been reset and the sensitivity has been adjusted

RY4 = POTTER BROOKFIELD
 Part # - K10P-11D15-12

CRYY = P/N# 1M4003 DIGITKEY
 CRXX =

| | |
|--|---|
| | 6 PIN SCHEMATIC |
| | SW2 |
| Author: Paul Wood Checked: Franklin D. Wood Date: January 2000 | P/N# 405; 5224 WESP SR-96 SIGNALARM, FL 3277/328-947 FAX (407) 328-5889 |
| DATE: January 2000 | SHEET: 1 of 1 |

| REVISIONS | | |
|-----------|-------------|---------------|
| REV | DESCRIPTION | DATE APPROVED |
| | | |



STEP 2

SOLDER BLACK AND WHITE WIRE TOGETHER WITH SOLDER PROVIDED



STEP 3

PLACE WIRE NUT ON SOLDERED WIRES



STEP 4

THEN PLACE SHRINK TUBE PROVIDED OVER WIRE NUT AND PIGTAIL CABLE



STEP 5

CUT PIGTAIL TO DESIRED LENGTH, BUT AT LEAST 12" LONG

STEP 1

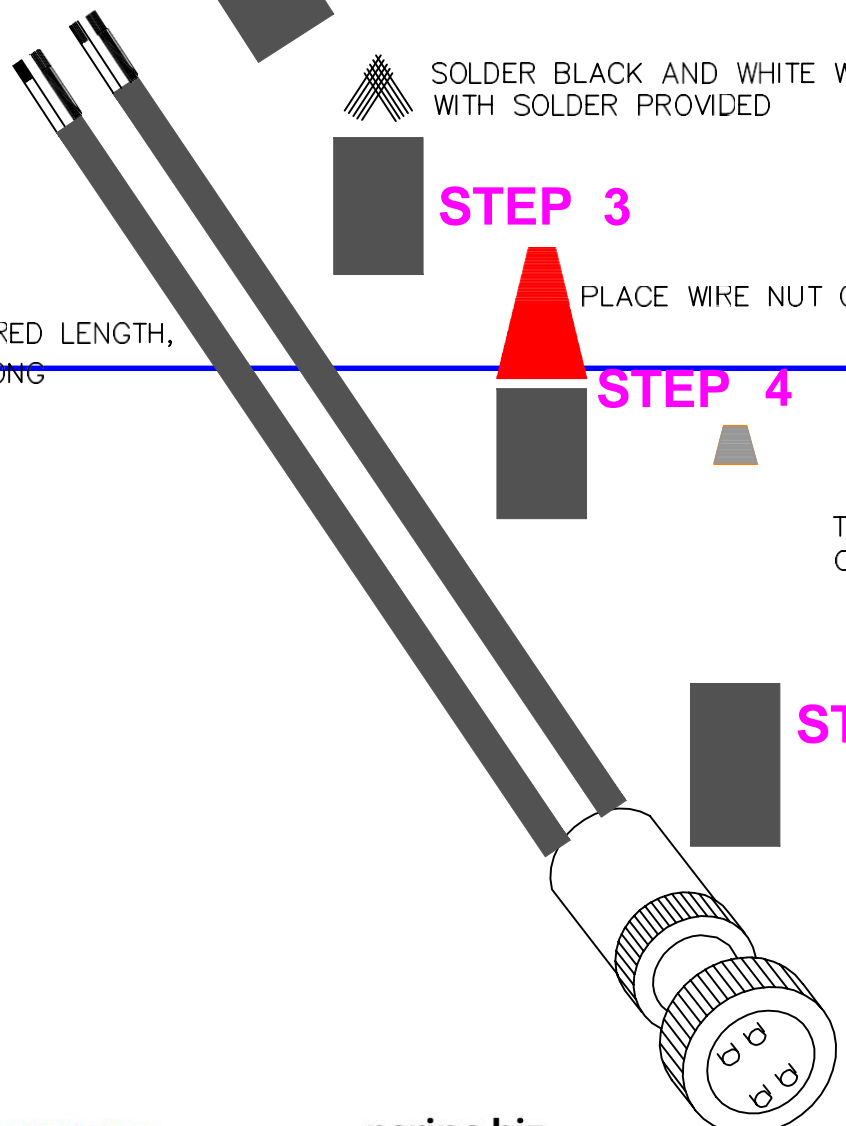

| | | |
|---|-----------------|----------|
|  | DWG NAME: | |
| | PIGTAIL DIAGRAM | |
| DRAWN: | | |
| CHECKED: | | |
| DATE: | DWG NO. | SHEET OF |

Paul Wood

1-2000

1 1

Trouble Shooting

Q. Green LED Power light does not come on

- Check that the battery cable is connected to the battery with correct polarity
- Clean and tighten battery connection
- Verify that the equipment is negatively grounded

Q. Green LED power light goes out when hold to test button is depressed

- There is a break in the antenna cable.
- LED could be defective or

Q. External speaker does not sound when hold to test button is depressed but the green light stays lit, red light flashes, and internal speaker sounds

- Check connections and cable for kinks or breaks
- Check control module to ground and verify 4 amps power supply

Q. Horn (quacks) this usually means a bad ground from the control module

- Insure the red wire in the white cable from Sigalarm is attached to the yellow/horn
- Insure that the black wire in the white cable from Sigalarm is attached to the white/horn
- Insure that the Sigalarm control module is grounded to the chassis
- Insure that the chassis is grounded to the negative terminal of the battery

If the system does not function properly after checking above

Remove the black wire from white cable and hook up a test wire from the white cable on the (horn) to the negative terminal on the battery and hold test button to test. If the system functions properly when the test wire is connected it indicates that the chassis and Sigalarm are not properly connected to the battery negative terminal of the battery used for supply power.

- An additional relay from Sigalarm to the horn should also solve problem
- Check for low voltage supply problems
Try lengthening the cable to the horn. Low voltage supply might be affecting the operation of the horn causing a short term signal drop. The longer the wire is to the horn the more inductance (less of a leap to end of wire) which does not allow the horn to draw as much current (6volt minimum to horn.) The shorter the wire is to the horn the more likely it is to cause a problem on a vehicle that has a marginal power supply
- Check the power supply that feeds Sigalarm under a full load for proper voltage
Note: 4 amp max draw while Sigalarm is in max alarming rate

Operation Introduction

The almost unlimited types, sizes, and configurations of equipment on which this system can be used make it impossible to cover every point of operation in a manual. However, the following diagrams and explanations should help you understand general operating considerations.

Remember, the Sigalarm system is a Range Control Warning Device, not a measurement device. It is designed to warn the operator and outside ground crews of encroachment on OSHA minimum distances to power lines.

After the Sigalarm system and its support hardware have been installed in accordance with the installation instructions that accompanied your device, the unit is ready for use.

Energized high voltage power lines are a constant and deadly danger to anyone working with or around equipment that can be raised 25 feet or more above the ground. No warning system should be used *in place of* standard safety rules and precautions. No device can **ABSOLUTELY PREVENT** an accident! When properly installed and operated, the Sigalarm system will provide sufficient warning to prevent encroachment.

GENERAL DESCRIPTION

The Sigalarm Range Control Warning Device consists of:

- An antenna sensor to protect the entire length of a boom
- A control module which contains the electronics to detect the electrostatic field surrounding all power lines, read the field strength, and activate the visual and audible warning alarms

This is a **WARNING** system and should not be used as a **MEASURING** device. It is designed to give reliable and repeatable warning of the presence of dangerous high voltage in the immediate vicinity as well as allowing the operator to set an approximate safe working distance and prevent encroachment to power lines. Operation is simple and requires no special knowledge of electronics, power line theory or electrical fields.

THEORY OF OPERATION

Your Sigalarm Range Control Warning Device is a reliable and finely tuned "radio" designed to receive only one selective and potentially life-threatening program - the detectible electric field present around all high voltage transmission (power) lines. Unlike your radio, which may pick up unwanted stations and/or static, your Sigalarm system will only receive 60Hz. The unit can also be adjusted to alarm at 50Hz for countries having 50Hz power lines.

The strength of the signal (field) depends on the voltage and the distance from the lines. For example, the field strength of 110 volts at 15 feet would be roughly the same as created by 11,000 volts at 150 feet. Simple adjustment of **COARSE** and **FINE** controls on the Sigalarm unit permit accurate and repeatable settings at which an operator would like a warning. After the original desired setting is made, a visual and audible alarm will occur whenever the "encroachment zone" is approached.

Dual Function Notes

Your Sigalarm Range Control Warning System can perform in two different modes.

1. As an automatic early power line warning system. Anytime your system is turned on whether activated at start-up of engine, when wired through the ignition, or by another source, it will automatically be at its most sensitive setting, warning the operator that he is in the vicinity of a high voltage power line. The operator does not need to set or adjust the system for it to operate in this mode; it occurs automatically.
2. As a range control warning system. Once the operator has been alerted to the vicinity of an energized power line in his work area, he may choose to stay far away! If the job assignment calls for working in close proximity to the power line (No closer than OSHA minimums!), the system can be set to alarm any time the boom or jib tip comes within the encroachment zone. (See operating instructions.)



WARNING NOTES



**Sigalarm is not intended to replace any existing safety precautions.
It is solely provided to be used as an additional tool.**

- It is dangerous to operate any high lift vehicle beneath or above high voltage lines.
- It is dangerous to operate any high lift vehicle in an electrical storm
- If multiple lines are present the Sigalarm should be calibrated to the lowest voltage line and additional preventative measures should be utilized.
- The operator **MUST** fully understand how the Sigalarm is installed, operates, and limitations before use
- It is highly recommended that installation be done by a certified installer or competent person
- It is highly recommended operator training should be done prior to use by Sigalarm, its representatives, or a competent person
- Atmospheric electrical storms generate a similar field to voltage transmission lines, the Sigalarm may be activated during these storms, depending on distance and intensity.
- When operating in close proximity to high voltage power lines vehicles should be prohibited from traveling between the boom and power line.
- Recalibrate Sigalarm when operating the boom angle and length significantly different than that used for the last sensitivity setting

FRONT PANEL FAMILIARITY

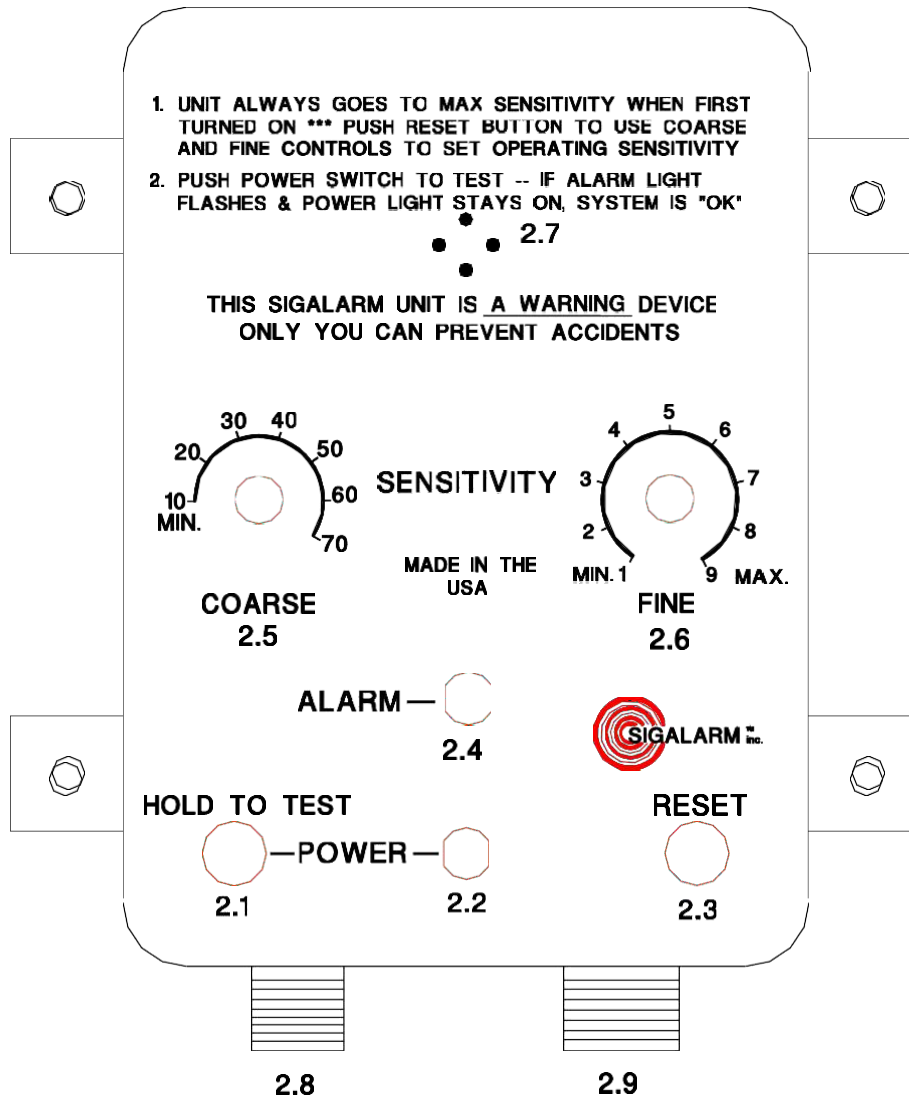

HOLD TO TEST BUTTON - allows the operator to test the entire system by pushing and holding down this button. This then checks the entire system. If the green power light stays on, external horn sounds, internal buzzer works, and red light flashes the system is fully functional. If any of these are not working contact your supervisor and fix prior to use. If any of these fail there is either a break in the antenna, a jumper pin problem, or there is an internal failure.



Warning: If any of the alarm indicators above do not work while depressing the hold to test button notify your supervisor immediately. DO NOT OPERATE the unit

GREEN POWER LIGHT-indicates power is on when power is applied. The green power light also indicates the condition of antenna when the hold to test button is depressed. If the green power light stays on this indicates that the antenna is ok. If the green power light does not stay on, that indicates that there is an open circuit or break in the antenna.



Warning: If any of the alarm indicators above do not work while depressing the hold to test button notify your supervisor immediately and DO NOT OPERATE the unit.

RESET BUTTON - allows you to take unit off max sensitivity and use the coarse and fine controls to adjust sensitivity. Push and release the reset button to take unit off maximum sensitivity. The unit is now at its last setting. The coarse and fine controls must be used to adjust sensitivity up or down as needed.

Each time the power is turned off and on, the control module will automatically be at maximum sensitivity. You will need to press the reset button each time power is turned off so that you can adjust the sensitivity by using the coarse and fine knobs, see operational instructions.

RED ALARM LIGHT - flashes when the encroachment zone has been reached, or when the hold to test/reset button has been depressed. (Interior and exterior horns are also activated simultaneously.)

COARSE CONTROL - changes sensitivity/response to field strength/signal by a factor of 10 times per step.

FINE CONTROL - changes sensitivity/response to field strength/signal by 1 time per step – numbers 1 through 9 is used to set sensitivity more precisely.

INTERNAL HORN - audible that sounds at same time as red alarm light flashes and external horn sounds.

ANTENNA SENSOR CABLE INPUT CABLE (2 Pin cable assembly)

BATTERY CABLE INPUT (6 pin Cable Assembly) - Optional Auto shutdown, External horn, Power supply

3.0 GENERAL CARE

Your Range Control Warning System has been designed to be very rugged and *nearly* waterproof. However, the following "common sense" suggestions should give you years of "trouble-free" operation.

Cover the control module with a waterproof plastic case if it is subjected to constant and heavy streams of water.

Be sure antenna sensor leads and all cables are routed away from points of wear to prevent damage. Check your system daily by depressing the hold to test button

Operating Procedures for Sigalarm

High Voltage Power means any electrical line or lines installed above ground level having a voltage in excess of 750 volts between conductors or from any conductor to ground.

OPERATION:

Once power (12VDC) is applied to the control module, the unit will go to maximum sensitivity. If any power lines are in the vicinity of the crane (± 200 Feet of 12,500 v line) an alarm will sound. Push the reset button 1st then check the system by holding down the hold to test button and verify that the green power light stays on, red light flashes, the interior buzzer sounds, and the exterior horn(s) sound. This verifies that both the electronics and the antenna are working properly and you are now ready to set the alarm. The Sigalarm unit is now set at its last working position



Warning: If any of the alarm indicators above do not work while depressing the hold to test button notify your supervisor immediately. DO NOT OPERATE the unit.



Warning: this setting may NOT be appropriate for this job site. You must now manually set the alarm point using the sensitivity knobs as described below.



Warning: Do not begin work until the unit has been checked with the hold to test button and Sigalarm is set properly as described below. Never operate without testing and setting the Sigalarm.

The operator must insure that there are no overhead power lines above or in close proximity to the crane. After a complete visual check, pushing the reset button, and adjusting both the coarse and fine sensitivity knobs on the control module (as described below) the boom can be operated. The operator is in control of every jobsite; it is up to the operator to insure that there are no dangerous overhead power lines in close proximity to your crane.

When setting the Sigalarm for operation near a power line, the alarm set point should be adjusted far enough away from the encroachment distance to give the operator sufficient time to react. Use ground people to help estimate distance. The Sigalarm unit should be set to give sufficient encroachment warning at least 20 feet away from nearest line. Never approach any power line closer than the minimum safe distance set by OSHA for the power lines that you are working around. It is the operator's responsibility to know this distance.



Warning the load line has no antenna.

To properly warn against contact by the load line, set the Sigalarm at a distance 10feet greater for every 20feet of boom length longer than 60feet. (Diagram below show 45 angle as worst case-the higher angle brings the boom closer to the line: lower angle brings tip closer to the line.)

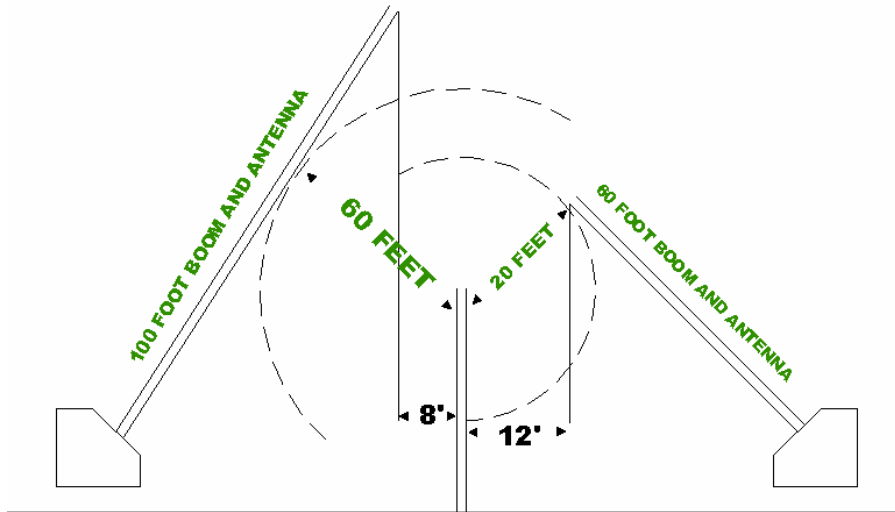

EXAMPLES:

- 60 feet total boom length - set alarm with boom 20 feet from power line
- 80 feet total boom length - set alarm with boom 30 feet from power line
- 100 feet total boom length - set alarm with boom 40 feet from power line

ADJUST THE SENSITIVITY BY USING THE FOLLOWING METHOD:

Adjust the control knobs up or down to increase and decrease sensitivity and locate the alarm set point. Adjust the fine control knob counter clock wise to silence the alarm. If, the alarm is still activated after turning the fine control all the way left (1 is the least sensitive setting on the fine knob), adjust the coarse control left one position and repeat the fine knob counter rotation from maximum 10- until the alarm stops. If using the auto shutdown feature the reset button must be pushed and held for approximately 2-3 seconds. This allows the boom to be raised. If in the process of raising the boom the alarm re-activates you must decrease the sensitivity again, and re-push the reset button.

Once the boom is in the desired position the coarse and fine control knobs should be adjusted to the maximum sensitivity position without alarming. The system is now active and will help protect you and the crane from encroachment. You can now swing the boom/ladder/extension away from the encroachment point and then back again to the alarm threshold to check your calibration. With the sensitivity controls set correctly; the alarm will sound whenever the preset encroachment zone is entered.



Warning: Never just turn the controls knobs all the way down to the left (least sensitive positions). This could endanger yourself and fellow workers.



Warning: Sigalarm must be calibrated at each location.

A common practice that should be used when operating the Sigalarm Range Control Warning Device is to run a system test at the beginning and end of each operating day. Push and hold the test button. While holding this button observe that the green power light stays on, red light flashes, the interior buzzer sounds, and the exterior horn(s) sound. This verifies that both the electronics and the antenna are working properly.

Sigalarm is NOT intended to be a replacement for safe work habits, training, the observation of state & federal laws, or common sense.



Warning: Never operate closer than Federal, State, and Local laws allow.

Remember local regulations may be more stringent than federal laws. Sigalarm is a tool to AID you. You must know and obey all laws and regulations required by OSHA, the utility company, the equipment manufacturer, and your employer. If you do not know these laws and regulations DO NOT USE SIGALARM.

***If both the knob shield and auto shutdown are being used, the operator cannot adjust sensitivity up or down to move the crane after an alarm. If pushing the reset button does not stop the alarm and close the internal relay then the operator must continuously hold down the reset button and move the boom further away from the power lines until the alarm condition stops.**

Please follow the above directions carefully; they could save you and your fellow workers lives one day.