



PAT

PAT

LOAD MOMENT INDICATOR

DS150

www.patamerica.co

PAT America, Inc.

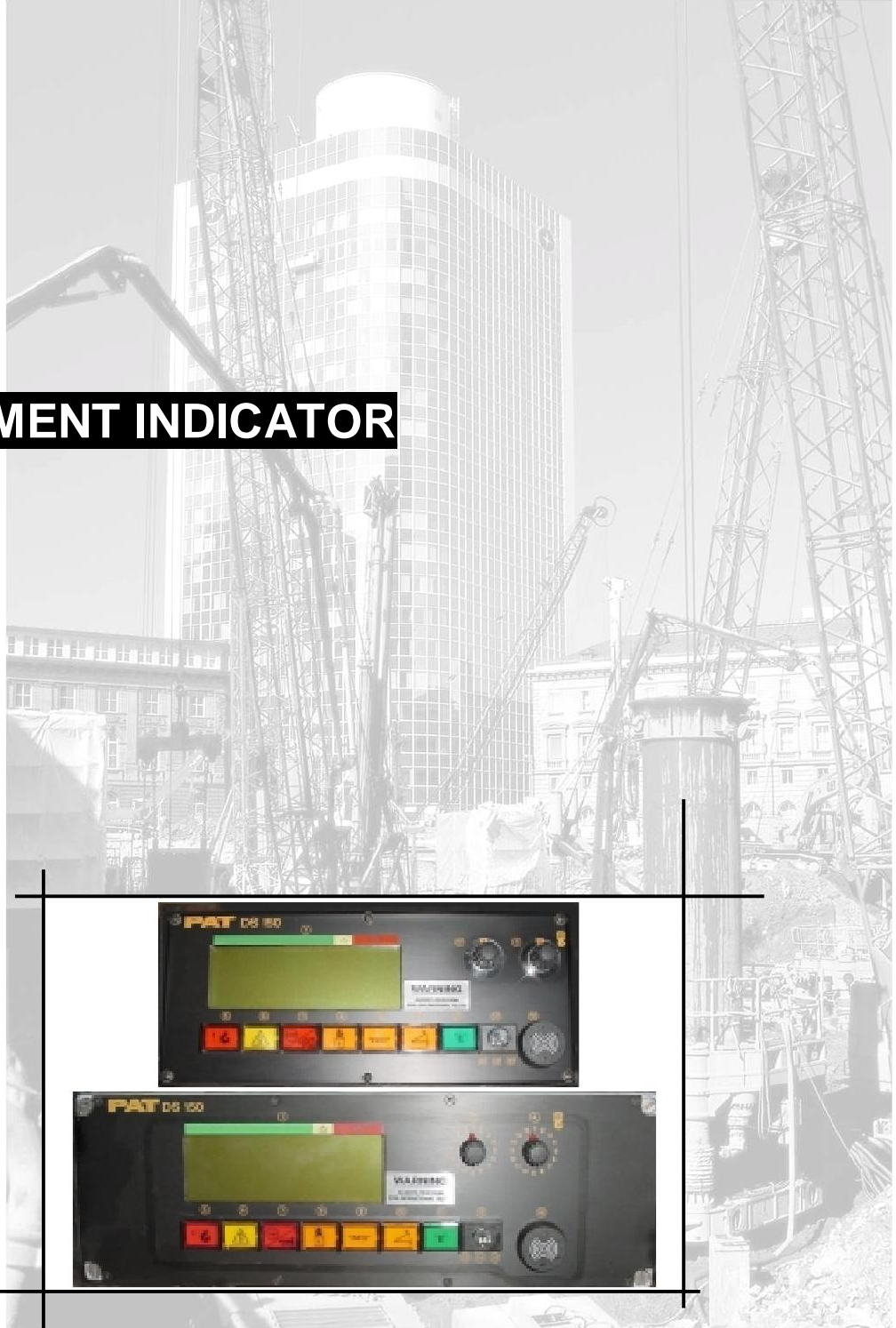

SERVICE MANUAL

P/N 031-300-100-753 REV A 10/16/2001



PSR Professional Service & Repair Inc.

Professional Service & Repair Inc. is a full-service mobile crane repair, inspection, and certification company. At Professional Service & Repair we understand the critical aspect of your crane being operational to your project schedule and budget. We will deliver world class service to have your crane operational in the minimum amount of time.

PSR is the global provider for sales, repair and installation of Load Moment Indicating (LMI) systems, Anti-Two Block Systems (A2B), and Rated Capacity Indicating systems. Please contact us with your crane repair and certification needs today.

PSR is the name businesses trust for crane repair, inspection, and certification.

Main Line: 706-718-0856

Fax: 706-569-7004

E-Mail: jeff@psrinc.biz

**P.O. Box 6506
Columbus, GA
31917-6506**

TABLE OF CONTENTS

1	MECHANICAL DESCRIPTION OF THE SYSTEM COMPONENTS	1
2	MECHANICAL AND ELECTRICAL DESCRIPTION OF THE CENTRAL UNIT	2
	BASIC SYSTEM COMPONENT LAYOUT.....	3
	BASIC ADJUSTMENT OF THE COMPONENTS	4
3	DEFINITIONS	5
4	DRAWINGS.....	6
	SYSTEM ELECTRICAL DIAGRAM.....	6
	CENTRAL UNIT 024-150-060-002 SPARE PARTS LIST	7
	CONSOLE 050-150-060-006 SPARE PARTS LIST	9
	CONSOLE 050-150-060-008 SPARE PARTS LIST	11
	CABLE REEL 068-208-060-013 LWG208 SPARE PARTS LIST	13
	CENTRAL UNIT BOARD LAYOUT AND MEASURING POINTS 024-150-300-001	15
5	PROCEDURE	16
	EPROM REPLACEMENT IN CENTRAL UNIT.....	16
	PISTON & ROD PRESSURE CHANNEL ZERO POINT ADJUSTMENT.....	16
	LENGTH & ANGLE ADJUSTMENTS.....	17
	MAIN BOARD REPLACEMENT.....	18
6	THEORY.....	19
	ANTI-TWO BLOCK & SHUTOFF CIRCUIT	19
	LENGTH MEASURING CHANNEL	19
	PISTON SIDE PRESSURE MEASURING CHANNEL.....	20
	ROD SIDE PRESSURE MEASURING CHANNEL	20
	MAIN BOOM ANGLE MEASURING CHANNEL.....	21
	SECOND ANGLE MEASURING CHANNEL.....	21
7	TROUBLESHOOTING FLOW CHARTS.....	22
	GENERAL FLOWCHART.....	22
	LEVER LOCKOUT ACTIVATED.....	23
	BROKEN LENGTH CABLE	24
	NO DISPLAY	25
	ANTI TWO BLOCK PROBLEM.....	27
	LENGTH READING PROBLEM	30
	LOAD READING PROBLEM.....	33
	BAD DATA TRANSFER BETWEEN CONSOLE & CENTRAL UNIT.....	36
	INTERFERENCE PROBLEM.....	38
	ANGLE PROBLEM.....	39
8	ERROR CODE TABLE	40
	ADDENDUM A BASIC ADJUSTMENT AND VOLTAGE CHECKS	46
	ADDENDUM B REFERENCE TABLES FOR MEASURING SUPPLY AND SIGNAL VOLTAGES FOR SENSOR CHANNELS	47

1 MECHANICAL DESCRIPTION OF THE SYSTEM COMPONENTS

Pressure Transducer: The pressure transducer transforms hydraulic pressure into an electric analog voltage signal. Two pressure transducers are connected, one to the rod side and one to the piston side of the lift cylinder. The pressure transducer is connected to the central unit with a four-conductor, double-shielded cable.

The power supply voltage is $\pm 5V$.

The output signal is 0.00V under 0 pressure to -1.00V at max. pressure (4410psi)

The Length-Angle Transducer: The length-angle sensor (LWG) is a combination of two transducers in one box, fitted at the base section of the boom. It measures the length and angle of the boom.

A reeling drum drives a potentiometer, which is the length transducer. Part of the length transducer is the length cable on the drum, which is a two-conductor cable (screen and live). It is connected to the anti-two-block switch at the boom head and to a slip ring body in the reel. The angle transducer is fitted into a small box filled with oil. A pendulum drives the axle of the angle potentiometer.

The power supply voltage for both is -5.00V

The output signal for the length transducer is: -0.500V up to -4.500V

The output signal for the angle transducer is: -1.875V up to -3.125V

Anti-Two-Block Switch: The anti-two-block switch monitors the load block and its relationship with the head of the boom. In working condition, the switch is closed. When the hook block strikes the weight, the circuit opens, disengaging a relay output to the lockout solenoid valves, where applicable. To check the cable for damage, (short circuit to ground) there is a 4.7k resistor between ground and the contact of the switch. The weight at the anti-two-block switch keeps the switch closed until the hook block strikes it.

Console: The console displays the geometrical information such as length and angle of main boom, working radius and head height of the boom. It also displays the actual load and the maximum load permitted by load chart. Furthermore, it has an alarm horn and a warning light for overload, and a pre-warning light. The analog instrument shows a percentage of the total permissible moment. The console has a switch for the operating modes (duty-selection switch for crane configurations) and a switch for the Reeving of the hook block. It also has a warning light for anti-two-block conditions and an override switch for overload or anti-two block condition.

Duty Selection Switches (Digital Inputs): The system has to be programmed for the lifting area configuration. The crane is going to be worked in (e.g. main boom) on outriggers over front, or rear, or over the side for 360 degrees. For obtaining this information from the crane, micro switches are installed in the electrical swivel that tells the system the exact location of the boom. Micro switches are also located on the counterweight which tells the system if the counterweight is installed or not, where applicable.

2 MECHANICAL AND ELECTRICAL DESCRIPTION OF THE CENTRAL UNIT

All the data of the crane is stored inside the central unit in EPROM's. The central unit receives all actual information of the crane. This is computed against the reference data and the crane status is continuously monitored.

Description of the Housing: The central unit DS150 is a rugged, waterproof sheet steel housing. It is mounted on the left side of the turn table weldment or on the counterweight. The cables are led into the central unit via strain reliefs and connected with fast-ons. An override switch is mounted on the housing, which overrides the LMI function. The system is protected by a 2-AMP fuse, which is mounted on the lower right side. The output signal is protected by a 10-AMP fuse, mounted on the lower mid.

Description of the Boards: Inside the central unit (CU) there is a main board. The main board and CPU is the heart of the system, and it contains the processor and the system and data EPROMs. The system EPROM holds the operating system and data EPROM hold the crane and calibration information. The wires from the various components are connected with fast-ons to the main board. The main board holds the electronics necessary to receive, evaluate, and direct the continuous flow of data from the sensors to the processor.

Main board components:

Power supply: Provides all the necessary voltages for the transducers and the electronics on the main board.

Analog input part: Receives and prepares all the signals from the transducers for further processing.

Relays, an overload and anti-two-block relay: Controls the Bosch relay for lever lockout.

Incoming Signals: Signals from the transducers are connected to the main board. The signals vary depending on the sensor:

Angle transducer signal is between -1.875V and -3.125V.

Length transducer signal is between -0.500V and -4.500V.

Pressure transducer signals are between 0.00V and -1.00V. (measured between the negative and positive outputs)

Anti-two-block switch resistance is 4.7Kohms.

Digital inputs for the duty selection switches are on or off.

Outgoing Signal: The outgoing signal of the main board is the signal for lever lockout of connection #48. In normal working conditions there are 12 volts at this connection. If there is an overload or anti-two-block condition the signal becomes 0 volts. Furthermore, all voltages for the transducers are going out through the main board.

Basic System Component Layout

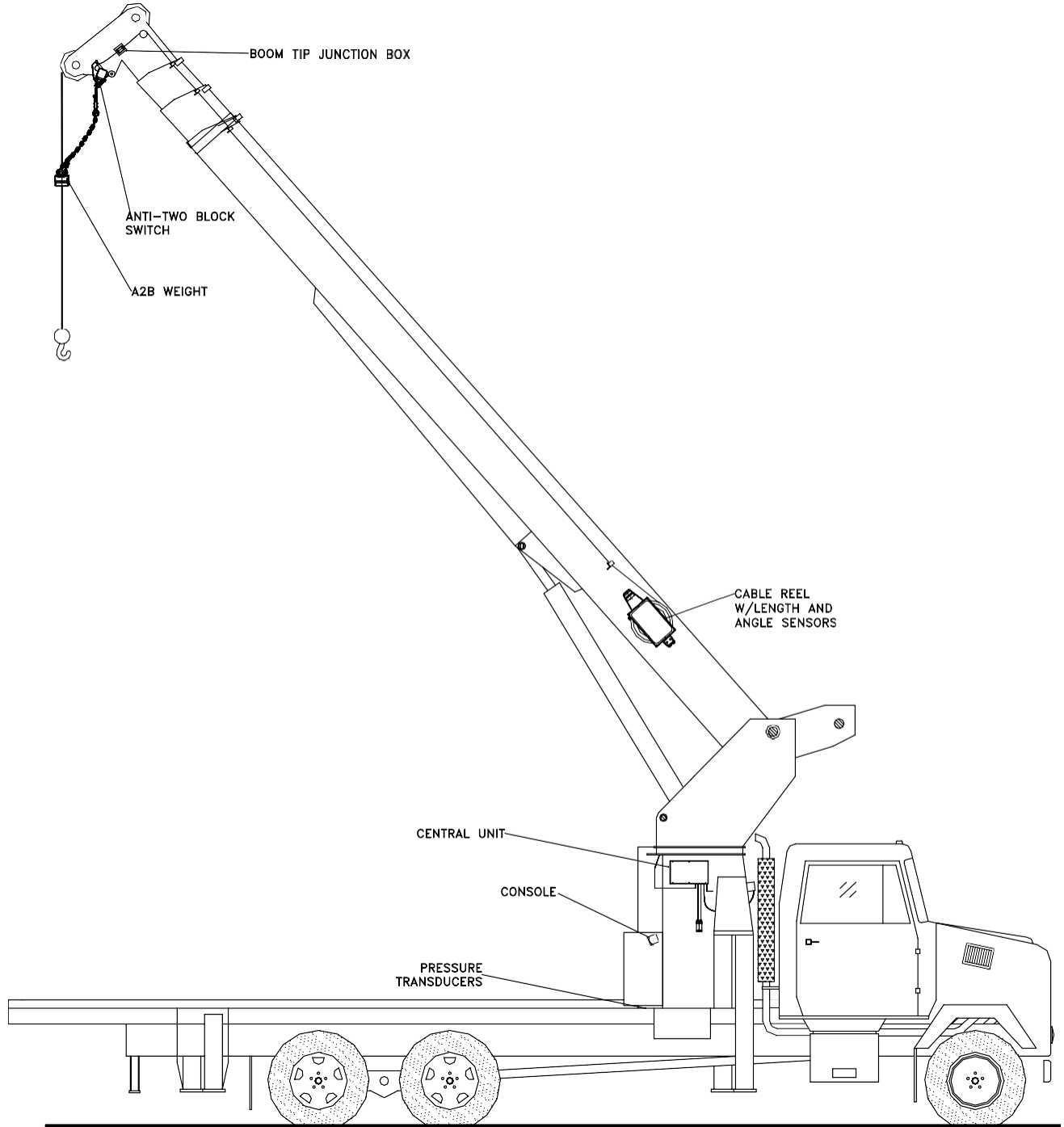

Basic Adjustment Of The Components

Length: Ensure that the length cable tension is correct with fully retracted boom and no tension on the cable reel. Turn the cable drum 5 to 8 turns counter clockwise. Then remove cover from cable reel and adjust the potentiometer counter clockwise to end stop. See Procedure 3.

Angle: Set the boom between 0 and 5 degrees and set the inclinometer to the boom angle. Adjust the angle sensor to the same angle as the boom. Check the angle at 20 degrees, 45 degrees, and 70 degrees. Angle display should be less than $\pm .5$ degrees of the value of the inclinometer. See Procedure 3.

Pressure Channel: Rest the boom and disconnect hydraulic hoses from the pressure transducers. Measure and record the zero-points of both pressure transducers on the main board. Adjust P1 and P2 on the main board to 500mV at test points MP11 and MP12. Connect hydraulic hoses back to the pressure transducers. See Procedure 2.

Duty Selection Switches Digital Inputs): Check the duty selection switches for correct operation. Check the voltage on digital input connections.

Check the function of the hoist limit switch (anti-two-block)
Check function of lever lockout.

Measure and record the power supply voltages. See Addendum A.

3 DEFINITIONS

BOOM LENGTH: The straight line through the centerline of boom pivot pin to the centerline of the boom point load hoist sheave pin, measured along the longitudinal axis of the boom. (Indicator $\pm 2\%$)

BOOM ANGLE: The angle between the longitudinal centerline of the boom base section and the horizontal plane. (Indicator 65° to 90° boom angle $+ 0^\circ/2^\circ$; less than 65° boom angle $+ 0^\circ/-3^\circ$)

RADIUS OF LOAD The horizontal distance from a vertical projection of the crane's axis of rotation to the supporting surface, before loading, to the center of the vertical hoist line or tackle with rated load applied. (Indicator 100% to 110%)

RATED LOAD The load value shown on the applicable load-rating chart of the crane for the particular crane configuration, boom length, boom angle, or functions or these variables. For radii outside those shown on the load-rating chart, the rated load is to be considered as zero.

ACTUAL LOAD The weight of the load being lifted and all additional equipment such as blocks, slings, sensors, etc. Also referred to as working load. (Indicator 100% to 110%)

CRANE CONFIGURATION The physical arrangement of the crane which is prepared for a particular operation in conformance with the manufacturer's operating instructions and load rating chart.

TWO-BLOCKING Contact of the lower load block or hook with the upper load block, boom point, or boom point machinery.

ANALOG: Electrical signals that vary in proportion to the quantities they represent. (Boom length, angle, and pressure transducer)

DIGITAL: Electrical signals of an on-and-off state (two different voltage levels) to represent some quantity of operation. (A2B, area definition switch)

4 DRAWINGS

SYSTEM Electrical Diagram

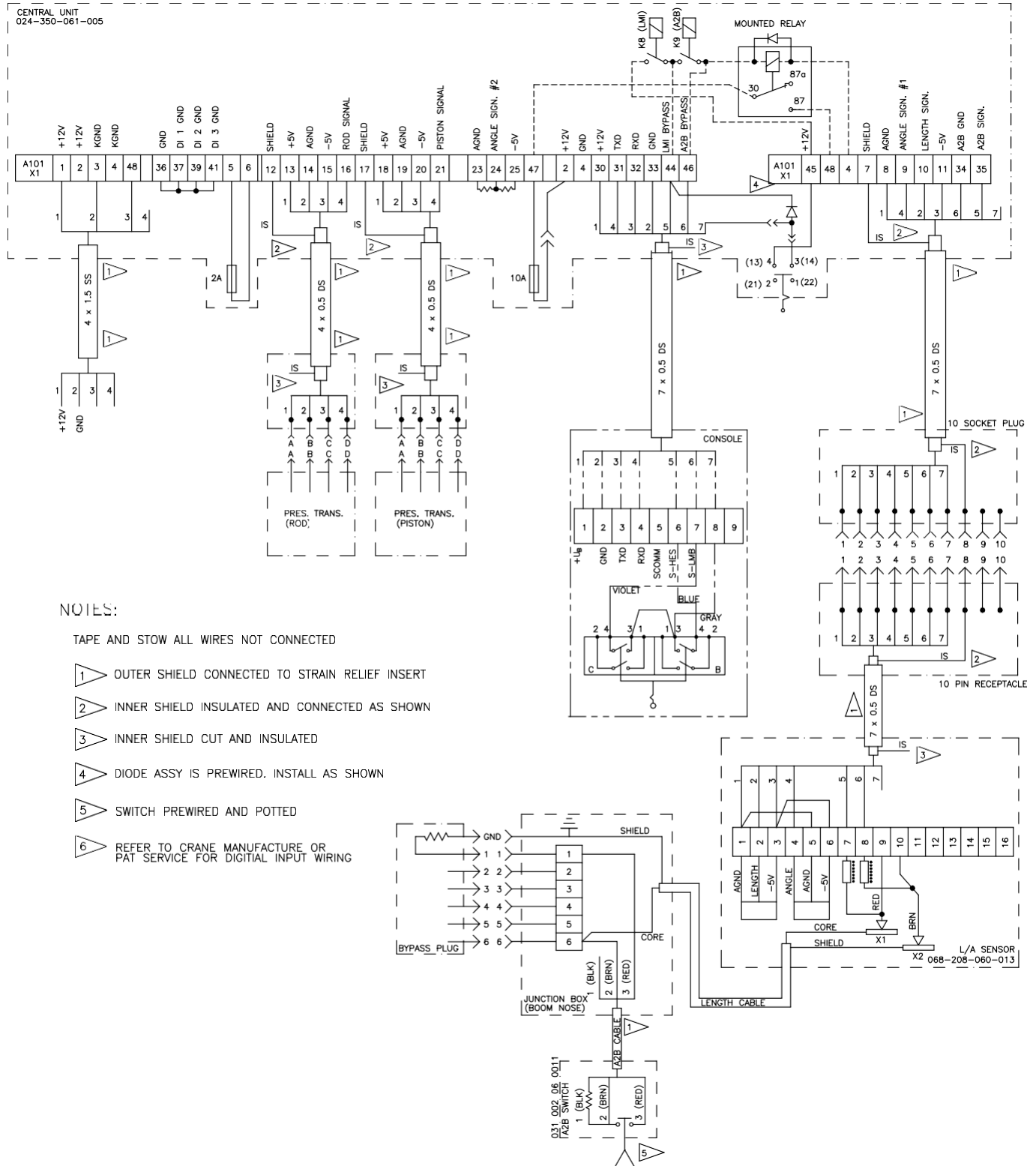

Central Unit 024-150-060-002 Spare Parts List

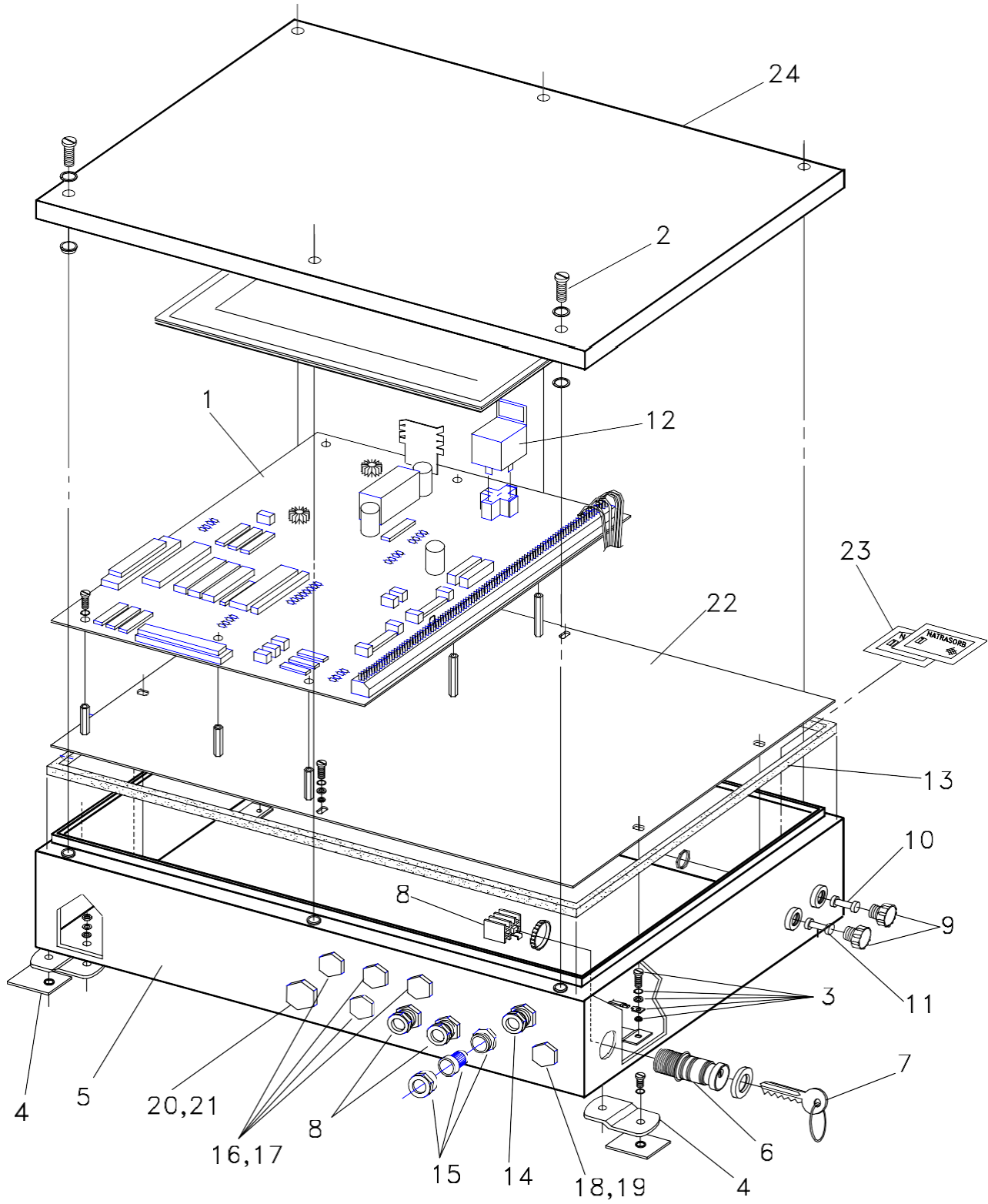

PART NO. 024-150-060-002 CENTRAL UNIT, DS150/0002 STANDARD PARTS LIST

NO.	PART NO.	QTY	DESCRIPTION
01	024-150-300-001	1	BOARD, MAIN, DS150, CU, 12V
02	024-350-100-135	1	CENTRAL UNIT ACCY, SCREW SET, DS150
03	024-000-100-041	1	CENTRAL UNIT ACCY, GROUNDING KIT FOR COVER
04	024-350-100-139	1	CENTRAL UNIT ACCY, WALL MOUNT SET, DS150/350
05	024-150-100-001	1	HOUSING, CENTRAL UNIT, DS150
06	024-350-100-661	1	KEYSWITCH, CENTRAL UNIT, NEW STATIONARY
07	031-300-101-131	1	KEY ASSY, ONE OLD STYLE KEY/ONE NEW STYLE KEY
08	024-350-110-067	2	STRAIN RELIEF ASSY, PG 11, GRN W/NUT+WASHER
09	000-314-022-006	2	FUSE HOLDER, CENTRAL UNIT, MAIN BOARD
10	000-313-062-001	1	FUSE, 2 AMP 1/4 x 1 1/4, 250V FAST-ACTING
11	000-313-062-002	1	FUSE, 10 AMP 1/4 x 1 1/4, 250V FAST-ACTING
12	000-304-140-122	1	RELAY, SHUT-OFF 12 V (BOSCH)
13	024-350-110-066	1	CENTRAL UNIT ACCY, GASKET, FOR C.U. COVER
14	021-441-161-213	1	STRAIN RELIEF, PG 13.5, 12-15mm GRY/WHT INSERT
15	050-350-110-116	1	STRAIN RELIEF ASSY, PG 13.5 RED, W/NUT+WASHER
16	000-214-340-011	4	STRAIN RELIEF ACCY, PG11 HOLE PLUG
17	000-214-210-011	4	NUT, PG11
18	000-214-340-013	1	STRAIN RELIEF ACCY, PG13.5 HOLE PLUG
19	000-214-210-013	1	NUT, PG13.5
20	000-214-340-016	1	STRAIN RELIEF ACCY, PG16 HOLE PLUG
21	000-214-210-016	1	NUT, PG16
22	024-150-100-002	1	CENTRAL UNIT ACCY, BASEPLATE, DS150
23	031-300-100-078	1	CHEMICAL, MOISTURE PACK
24	024-150-110-002	1	COVER, CENTRAL UNIT, DS150

4.4 Console 050-150-060-008 Spare Parts List

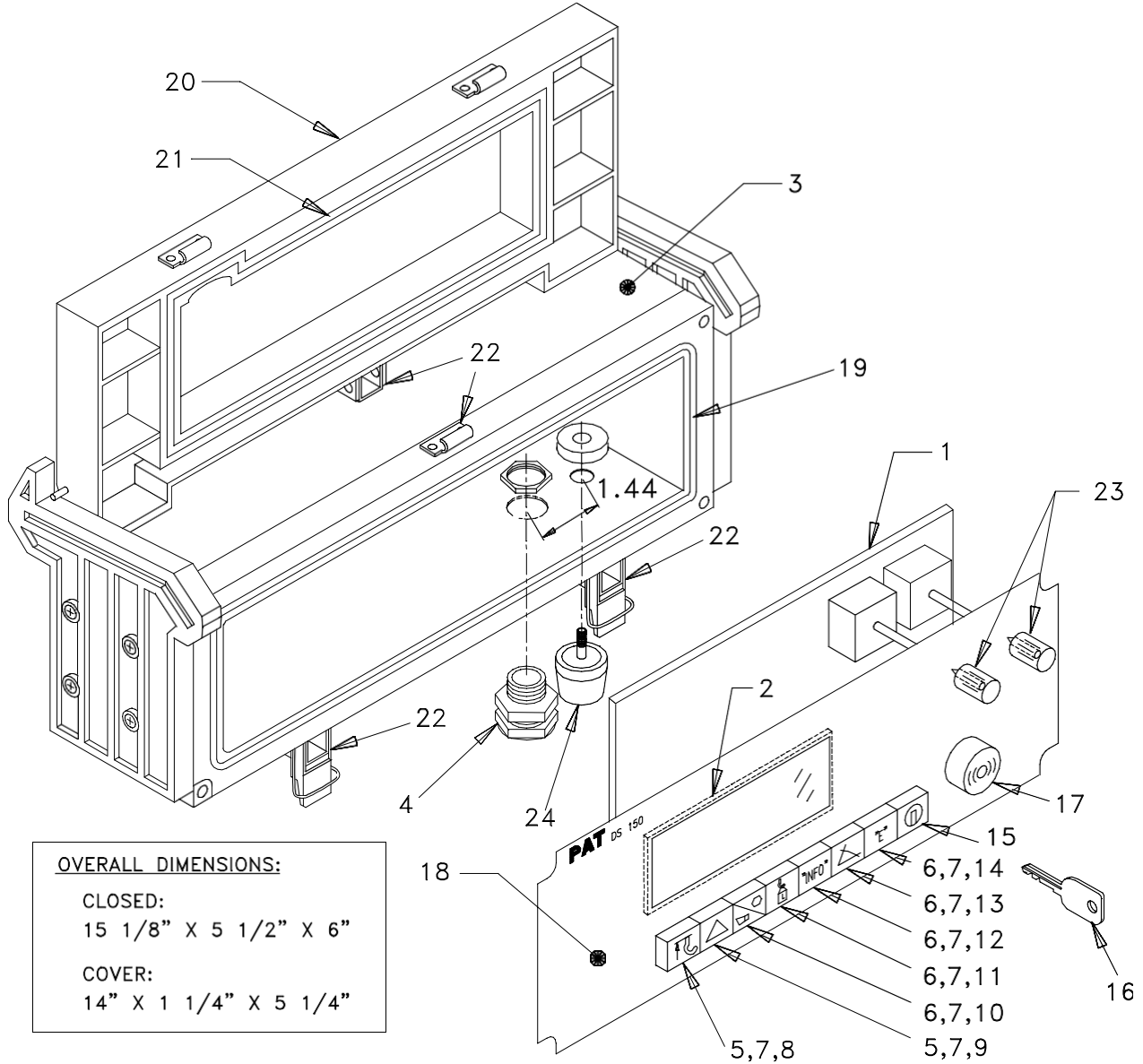

To change DS150/0006 (12V) to DS150/0036 (24V) a jumer wire must be soldered on main board, J3 added, and the lighth bulbs changed. When ordering spare part please specify 12 or 24 volt machine.

4.4 Console 050-150-060-008 Spare Parts List			
NO.	PART NO.	QTY	DESCRIPTION
01	050-150-300-003	1	CONSOLE BOARD W/ROTARY SWITCH - DS150
02	050-350-110-292	1	LCD DISPLAY DS150
03	050-000-100-060	1	CONSOLE HOUSING W/LID
04	050-350-110-116	1	STRAIN RELIEF/LONG RED
05	000-305-045-141	2	LUMINOUS HOUSING
06	003-051-405-423	5	LUMINOUS PUSH BUTTON HOUSING
07	000-311-023-114	7	LIGHT BULB 12V
07	000-311-023-128	7	LAMP, SPARE LIGHT BULB 28V
08	050-350-110-277	1	CAP A2B (RED)
09	050-350-110-278	1	CAP PREWARNING (YELLOW)
10	050-350-110-279	1	CAP STOP/ALARM OFF (RED)
11	050-350-110-280	1	CAP LOAD (ORANGE)
12	050-350-110-281	1	CAP INFO (ORANGE)
13	050-350-110-282	1	CAP ANGLE (ORANGE)
14	050-350-110-283	1	CAP ENTER (GREEN)
15	003-051-903-364	1	KEY SWITCH
16	050-350-110-139	1	CONSOLE OVERRIDE KEY DS150/350
17	050-000-110-007	1	ALARM BUZZER
18	050-150-100-006	1	FRONT PANEL
19	000-209-022-095	850mm	GASKET FOR FRONT PANEL
20	050-000-100-092	1	CONSOLE LID DS150/0006
21	050-150-110-005	1	GASKET FOR LID
22	050-000-110-014	3	LATCH ASSEMBLY
23	050-000-700-301	2	KNOB FOR ROTARY SWITCH
23	024-350-100-312	1	LABYRINTH MOISTURE ELEMENT

4.4 Console 050-150-060-008 Spare Parts List

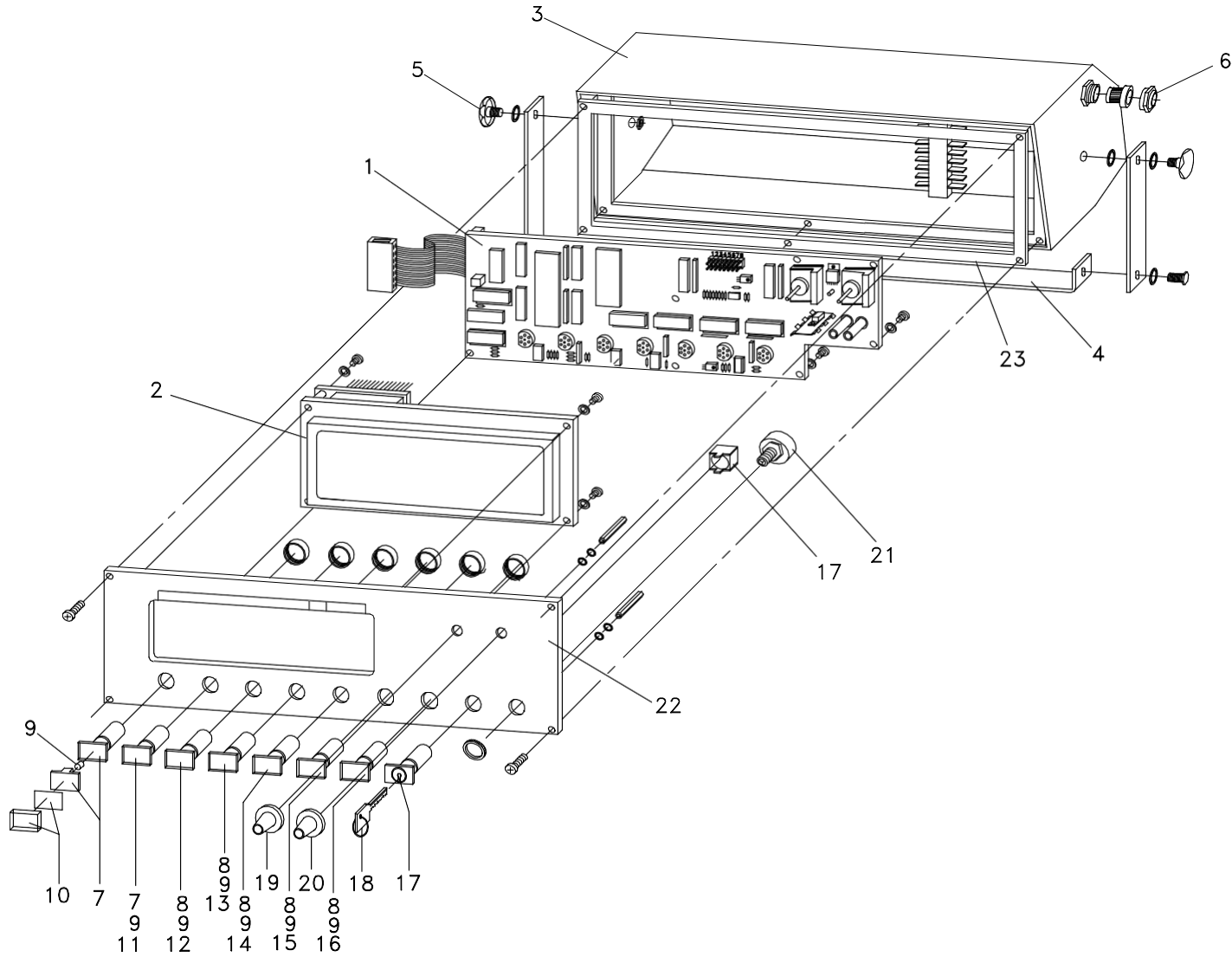

To change DS150/0008 (12V) to DS150/0012 (24V) a jumer wire must be soldered on main board, J3 added, and the lighth bulbs changed. When ordering spare part please specify 12 or 24 volt machine.

4.4 Console 050-150-060-008 Spare Parts List			
NO.	PART NO.	QTY	DESCRIPTION
01	050-150-300-003	1	BOARD, MAIN, DS150 CONSOLE 12V FOR 4x20mm DISPLAY
02	050-350-110-292	1	INDICATOR, DISPLAY, LCD, DS150 CONSOLE
03	050-000-100-048	1	HOUSING, DS150 CONSOLE, COMPLETE
04	050-150-110-001	1	BRACKET, CONSOLE, DS150 COMPLETE
05	050-350-110-183	2	KNOB, MOUNTING KNOB
06	050-350-110-116	1	STRAIN RELIEF ASSY, PG 13.5 RED/WHITE W/NUT+WASHER
07	000-312-043-141	2	LAMP ACCY, PILOT,BASIC HOUSING
08	003-051-403-423	5	SWITCH, PUSHBUTTON w/o LENS & BULB
09	000-311-023-114	7	LAMP, SPARE LIGHT BULB 12V
09	000-311-023-128	7	LAMP, SPARE LIGHT BULB 28V
10	050-350-110-074	1	SWITCH ACCY, LENS CAP, RED (A2B)
11	050-350-110-073	1	SWITCH ACCY, LENS CAP, YELLOW (PREWARNING)
12	050-350-110-075	1	SWITCH ACCY, LENS CAP, RED (STOP/BUZZER OFF)
13	050-350-110-076	1	SWITCH ACCY, LENS CAP, ORANGE (LOAD)
14	050-350-110-077	1	SWITCH ACCY, LENS CAP, ORANGE (INFO)
15	050-350-110-078	1	SWITCH ACCY, LENS CAP, ORANGE (ANGLE)
16	050-350-110-079	1	SWITCH ACCY, LENS CAP, GREEN (ENTER)
17	003-051-903-364	1	KEYSWITCH W/KEYS, CONSOLE DS150
18	050-350-100-001	1	KEY, CONSOLE KEYSWITCH
19	050-150-110-002	1	SWITCH ACCY, KNOB WITH SCALE DISK 1-63
20	050-350-110-140	1	SWITCH ACCY, KNOB WITH SCALE DISK 1-16
21	050-350-110-049	1	ALARM, BUZZER, DS150 & DS350C CONSOLE
22	050-150-100-008	1	FACEPLATE, DS150 CONSOLE, LARGE DISPLAY (STD.)
23	050-000-050-309	1	GASKET, HOUSING
24	002-053-703-101	1	SCREW, 3mm x 10mm, PANHEAD, PHILLIPS FACEPLATE

4.5 Cable Reel 068-208-060-013 LWG208 Spare Parts List

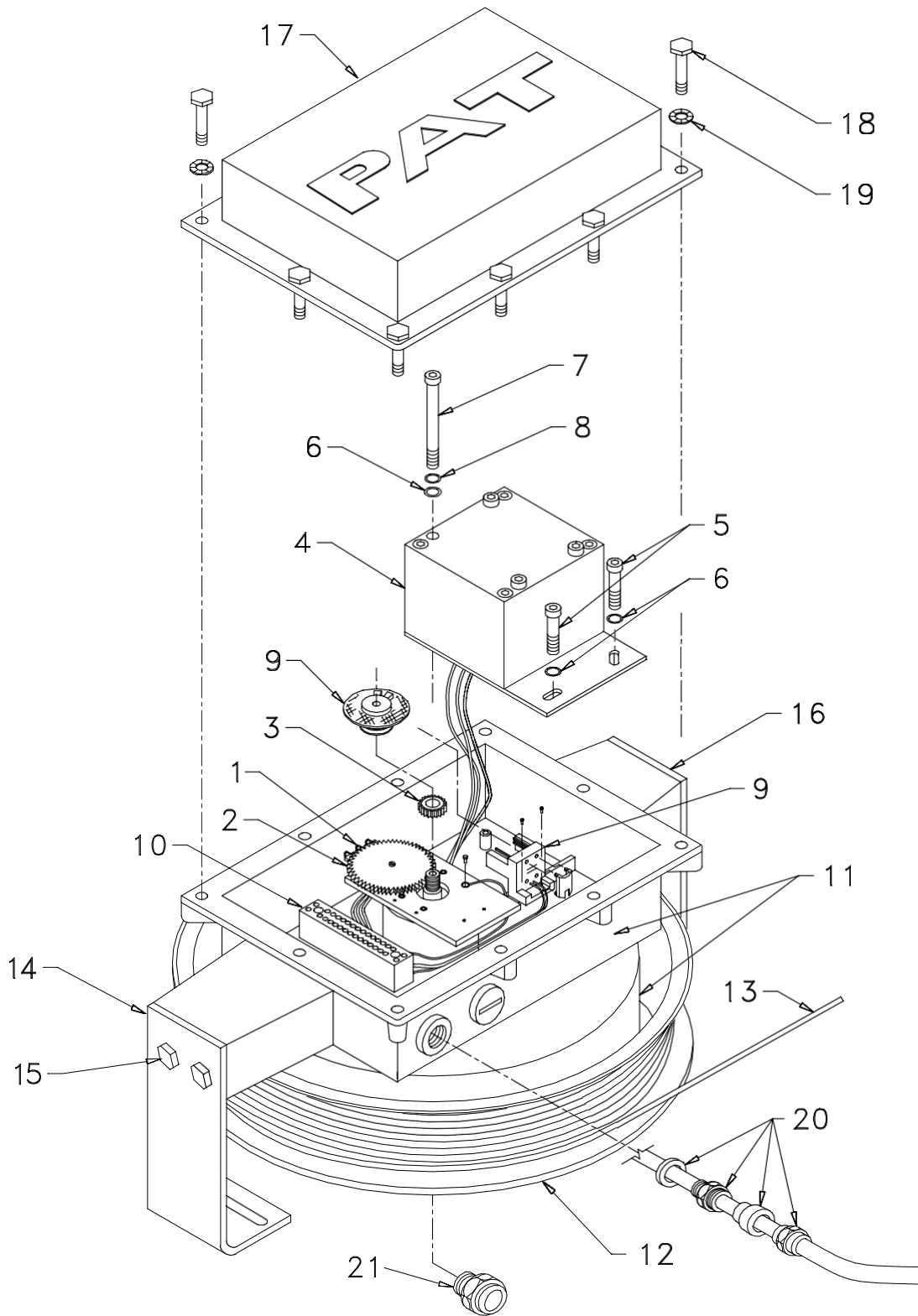

4.5 Cable Reel 068-208-060-013 LWG208 Spare Parts List			
NO.	PART NO.	QTY	DESCRIPTION
01	006-710-006-002	1	SENSOR, LENGTH TRANS. LGE 100 (KT200/LWG208)
02	068-000-110-038	1	SENSOR ACCY, GEAR WHEEL, KT200 CABLE REEL
03	067-000-050-065	1	SENSOR ACCY, GEAR WHEEL, T =50 CENTER SHAFT
04	064-103-060-002	1	SENSOR, ANGLE WG103
05	002-050-206-012	2	SCREW, 6M X 12 SOCKET CAP
06	000-207-010-064	3	WASHER, FLAT 6MM
07	002-050-206-100	1	SCREW, 6M x 100M SOCKET CAP
08	000-208-040-083	1	WASHER, LOCK 6MM
09	068-000-100-064	1	SLIPRING, 2 CONDUCTOR
10	068-000-110-029	1	CONNECTION STRIP
11	068-000-100-152	1	CABLE REEL, KT200 HOUSING,BKT,CABLE DRUM & NYLON CABLE COVER
12	068-000-110-011	1	CABLE REEL ACCY, CABLE DRUM,KT 200/ LWG208
13	000-673-020-002	139'	CABLE, LENGTH SENSOR, 1 CORE W/SHEILD (per ft)
14	006-800-005-058	1	BRACKET, MTG. CABLE REEL ARM, ONE SLOT
15	000-205-031-230	4	SCREW, 12mm x 30MM HEX HEAD
16	006-800-005-057	1	BRACKET, MTG. CABLE REEL ARM, TWO SLOTS
17	005-682-000-001	1	COVER, CABLE REEL, KT200
18	068-000-110-031	10	CABLE REEL ACCY, SCREW CABLE REEL COVER
19	000-208-020-006	10	WASHER, LOCK 6mm
20	021-441-131-013	1	STRAIN RELIEF, PG 13.5, 8-12mm RED + WHITE
21	000-214-030-703	1	STRAIN RELIEF, PG7 BLACK

4.6 Central Unit Board Layout And Measuring Points 024-150-300-001

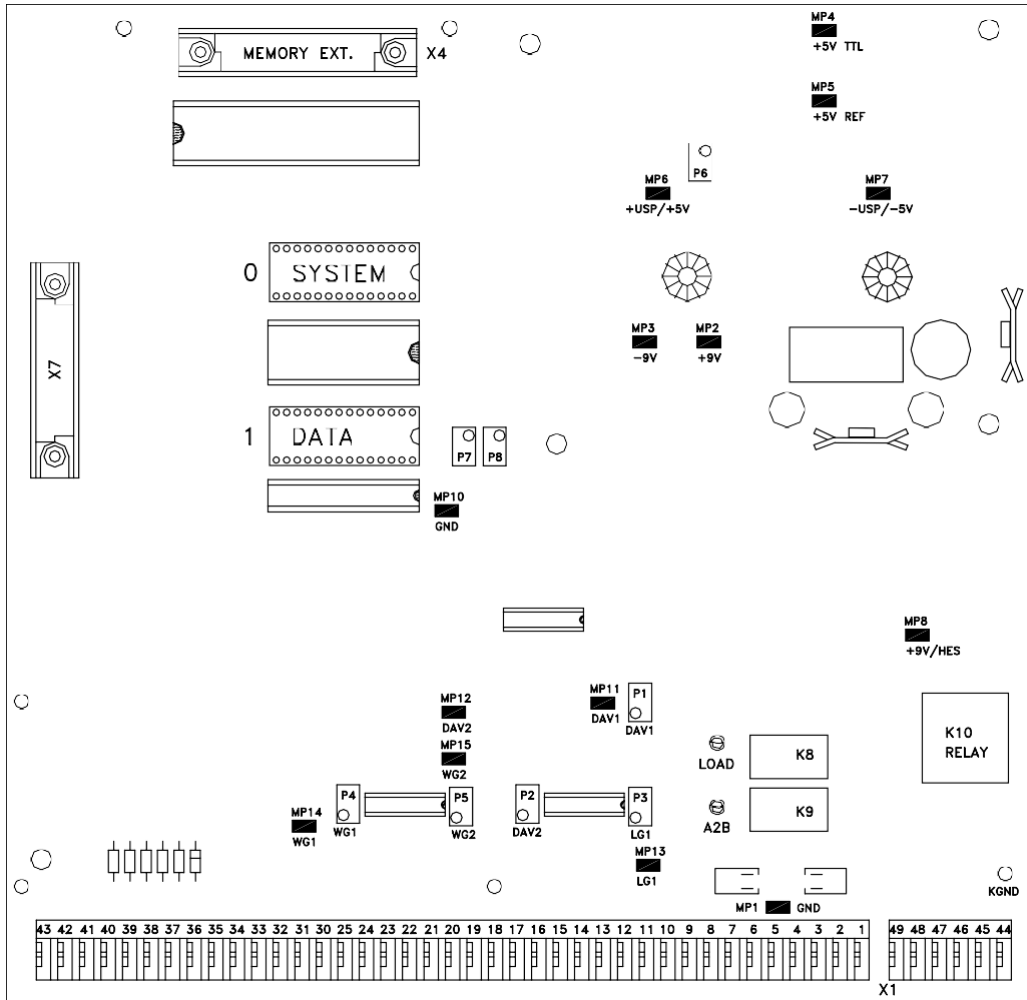

Measuring Points

- MP1: AGND
- MP2: +9V
- MP3: -9V
- MP4: 5V TTL
- MP5: 5V REF
- MP6: +5V/+UPS sensors supply
- MP7: -5V/-UPS sensors supply
- MP8: +9V HES
- MP10: AGND
- MP11: DAV1 piston pressure signal
- MP12: DAV2 rod pressure signal
- MP13: LW1 length signal
- MP14: WG1 angle signal #1
- MP15: WG2 angle signal #2

LED's

- LOAD: Overload relay ON(energized/normal conditions)/OFF (de-energized)
- A2B: A2B relay ON(energized/normal conditions)/OFF (de-energized)

5 PROCEDURE

4.6 Central Unit Board Layout And Measuring Points 024-150-300-001

EPROM replacement in Central Unit

Follow this procedure when changing EPROM's in the DS150 central units.

1. Remove cover, from central unit.

CAUTION: Before handling the EPROM, discharge any static electricity from your body by touching a ground source. The EPROM could be damaged if this procedure is not followed.

Use the central unit main board layout and measuring point drawing to locate the system and data EPROM's.

2. Remove the old EPROM from the main board using an EPROM puller. Be careful not to bend the legs of the EPROM when removing it.
3. Installing the new EPROM:
 - Ensure the notch is in the correct direction. The direction of the EPROM is determined by the notch on the end of the EPROM.
 - The DATA and TLK EPROM's fill the bottom of the socket as shown by the arrows.
 - Place EPROM in the correct EPROM socket as shown.
4. Inspect gasket and install cover using the following procedures to prevent any moisture from entering the central unit.

Reference material:

031-300-340-002 Central Unit Cover Installation and Tightening Procedure; Rev A.

031-300-340-003 Central Unit Gasket Recommendations; Rev -.

Piston & Rod Pressure Channel Zero Point Adjustment

Use the central unit main board layout and measuring point drawing to make the following adjustments.

1. Lower boom all the way down (no rest pressure) then disconnect hydraulic hose from the piston side pressure transducer.
2. Connect a digital voltmeter to main board
 - A) black (-) lead to mp10
 - B) red (+) lead to mp11
3. Adjust P1 to obtain a reading of 0.500 volts (500mv) on meter.
4. Disconnect hydraulic hose from the rod side pressure transducer.
5. Connect a digital voltmeter to main board
 - A) BLACK (-) lead to MP10
 - B) RED (+) lead to MP12
6. Adjust P2 to obtain a reading of 0.500 volts (500mv) on meter.
7. Reconnect hydraulic hoses to pressure transducers, and then bleed the air from hydraulic lines .

Length & Angle Adjustments

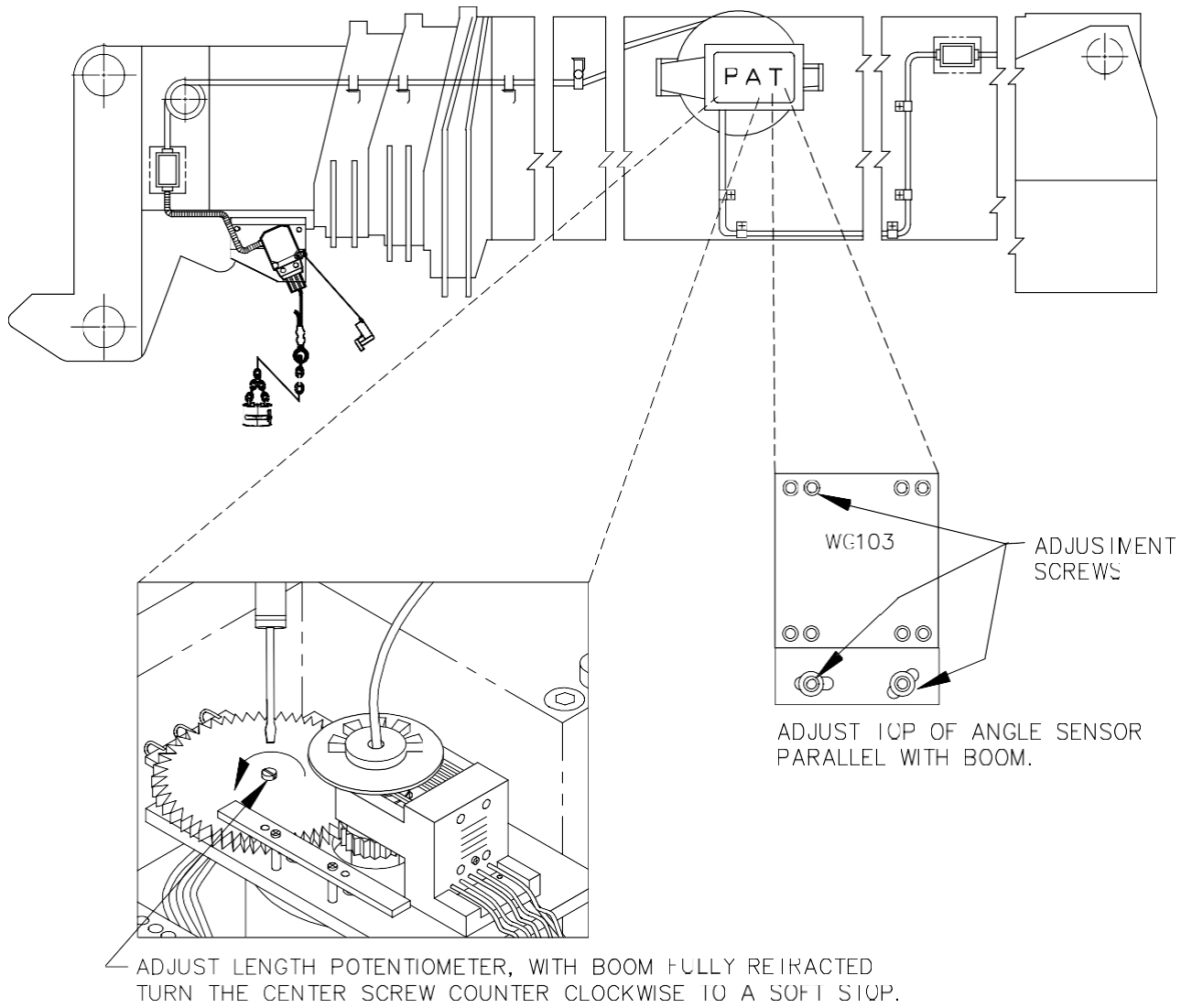

Main Board Replacement

Refer to Drawing 1, central unit parts list for board location.

1. Turn system power off.
2. Remove the central unit lid.

NOTE: Take care not to damage the boards with the screwdriver, when removing and inserting screws.

3. Remove the system and data software from the main board.
4. Remove the relay from the main board.
5. Mark all connection wires before removing, to identify location for reconnecting. Disconnect all X1 terminal wires from the main.
6. Remove the 9 large Philips screws holding the main board in place.
7. Note the orientation of the main board in the central unit. Remove main board and place it in the same packing material that the replacement in which the main board came.
8. Carefully insert the new main board in place.
9. Insert the 9 Philips mounting screws.
10. Insert the relay into the main board.
11. Insert the system and data software into the main board.
12. Connect the X1 terminal wires to the main board. Refer to Wiring Diagram.
13. Zero pressure transducers using the zeroing procedure in this section.
14. Inspect the gasket for nicks, cuts, or damages. Refer to 031-300-340-003 DS 350 Central Unit Gasket Recommendations, Revision - and 031-300-340-002 Central Unit Cover Installation and Tightening Procedure, Revision A

6 THEORY

Anti-Two Block & Shutoff Circuit

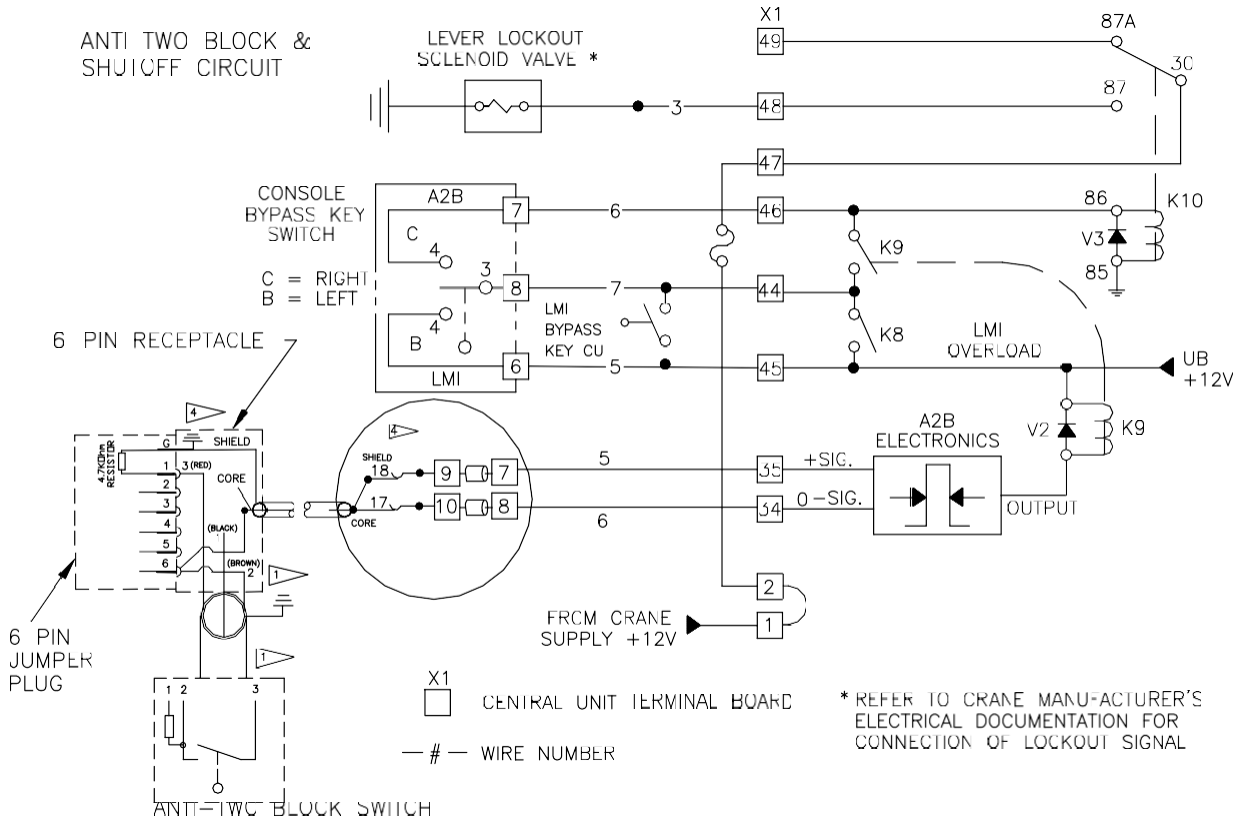

Length Measuring Channel

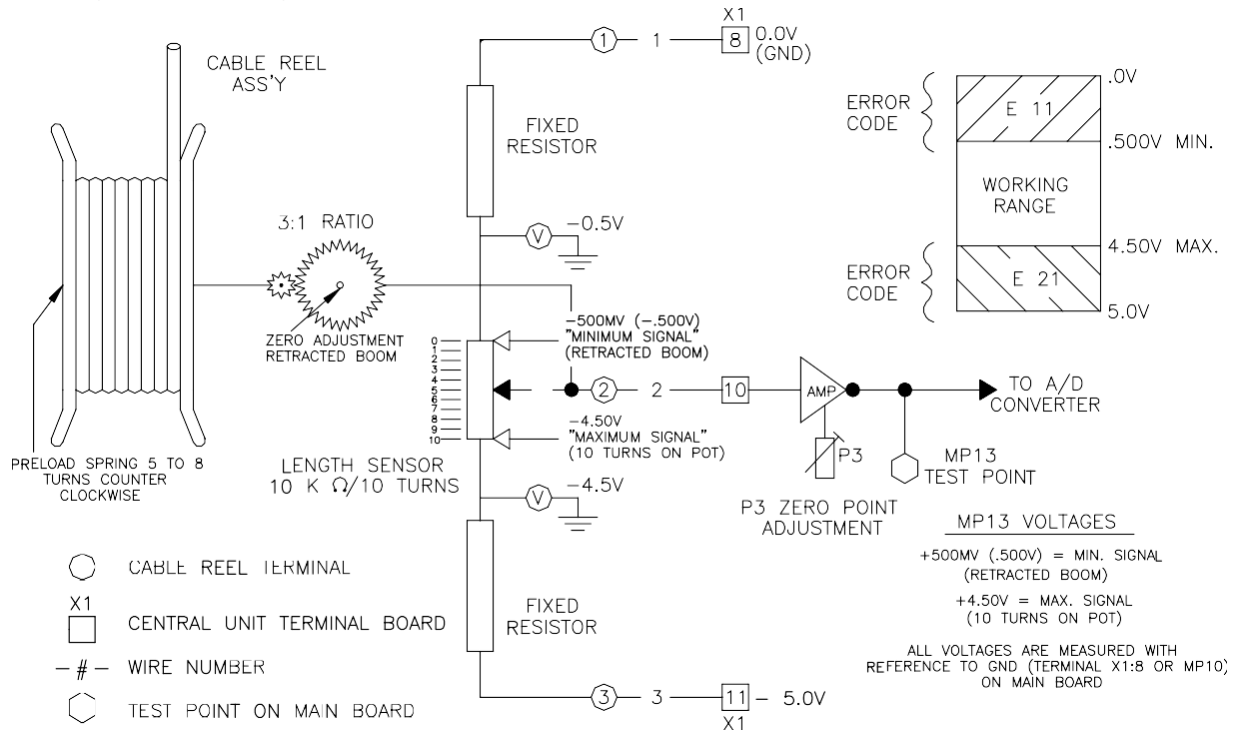

Piston Side Pressure Measuring Channel

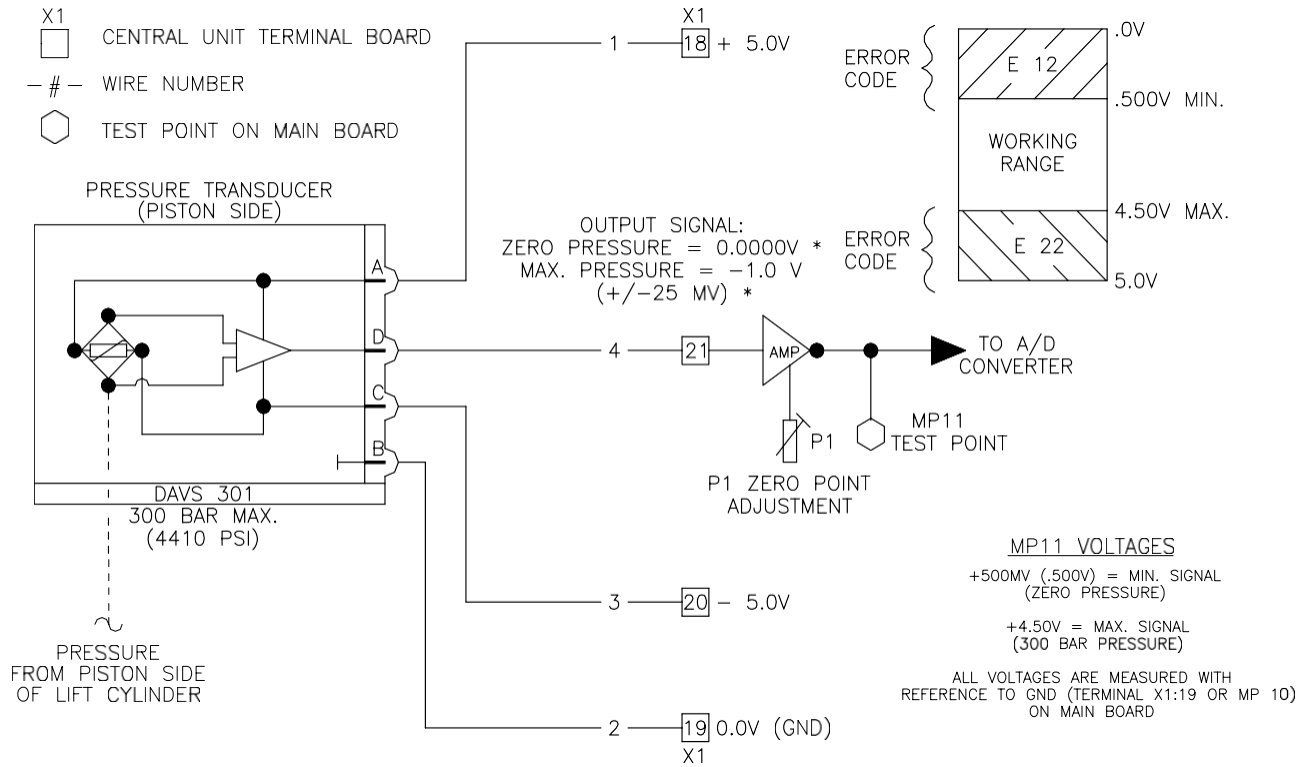

Rod Side Pressure Measuring Channel

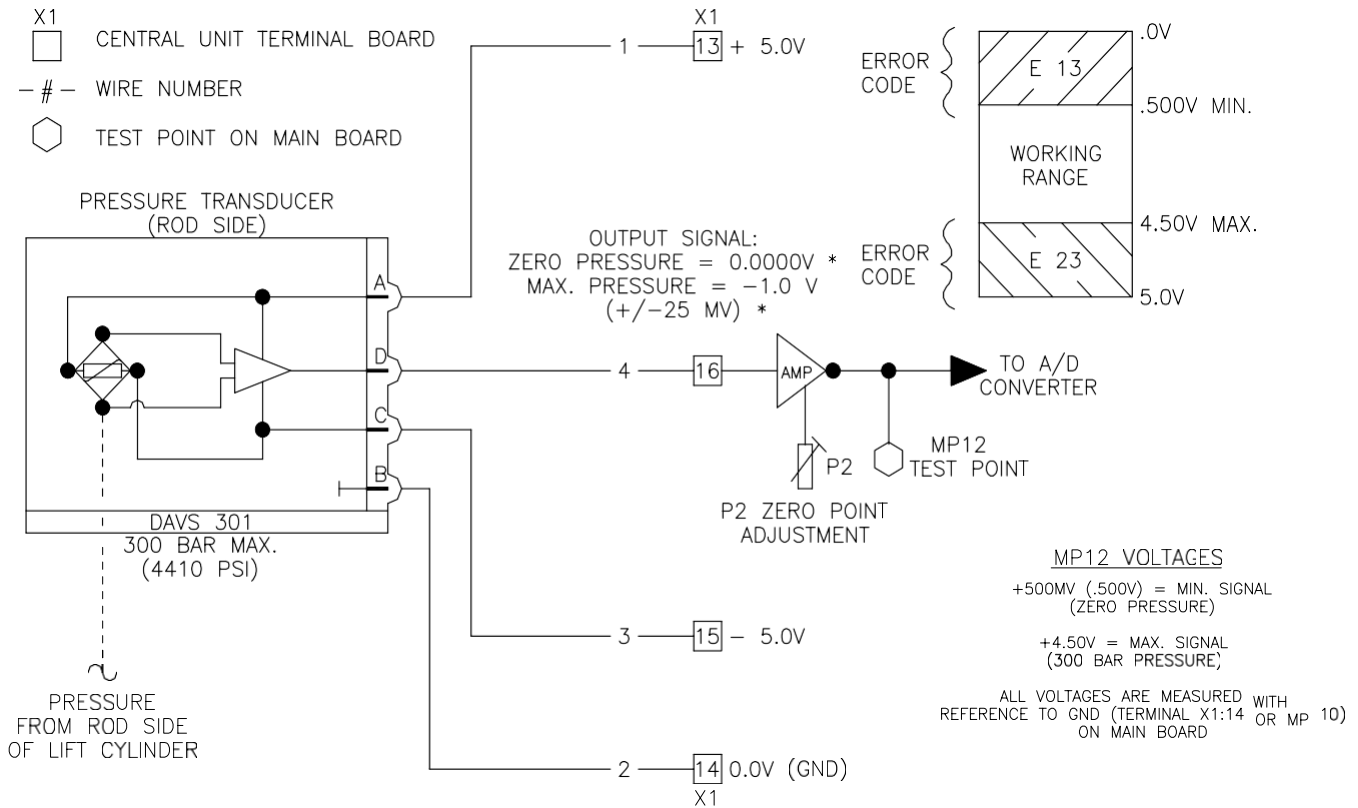

Main Boom Angle Measuring Channel

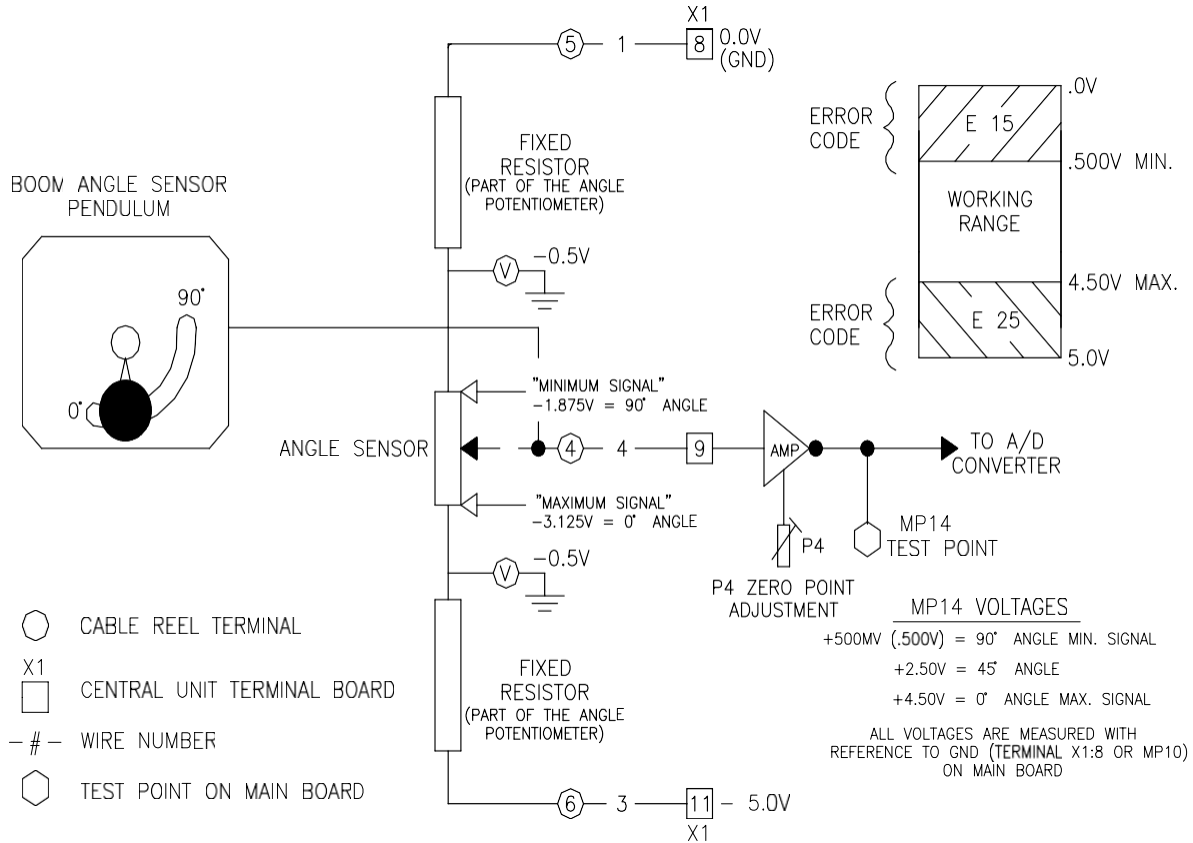

Second Angle Measuring Channel

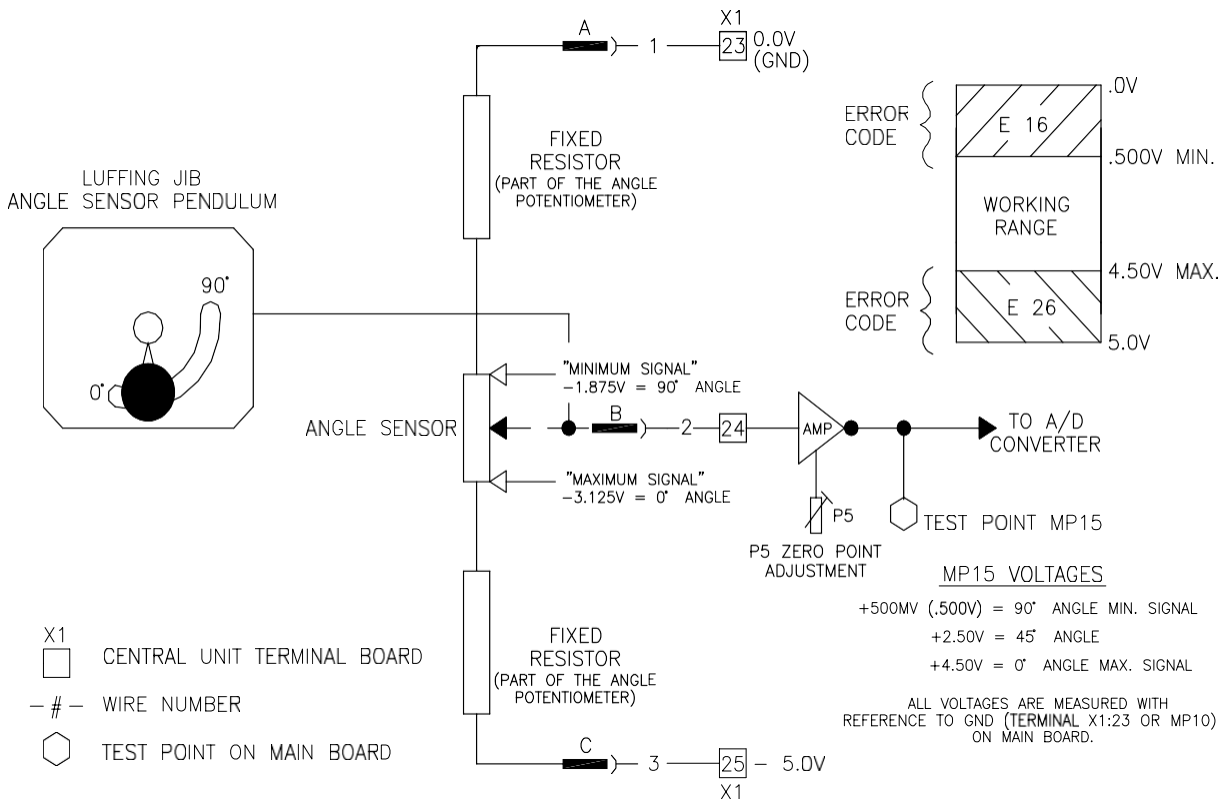

7 TROUBLESHOOTING FLOW CHARTS

General Flowchart

This section explains how to handle a problem that may arise with the PAT Load Moment Indicator System-PAT DS150. The procedures are easy to follow and are given in flowcharts on the following pages. Start with the general flowchart below, which will guide you to one of the detailed flowcharts shown in this section.

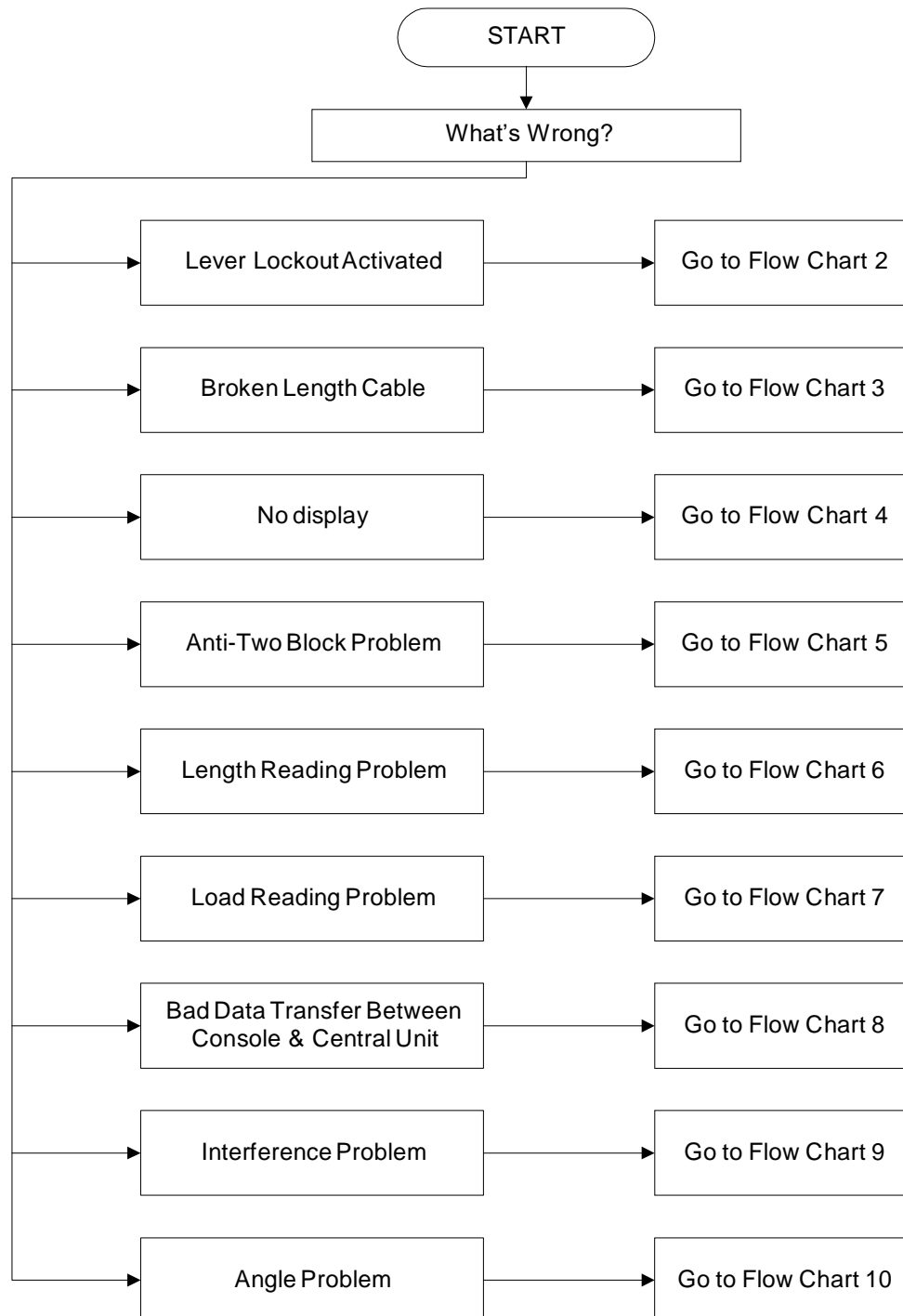

Lever Lockout Activated

PROBLEM: The lever lockout system of the crane is activated. Crane movements “hoist up”, “telescope out”, and “boom down” are stopped. Crane is not in overload or two-block condition.

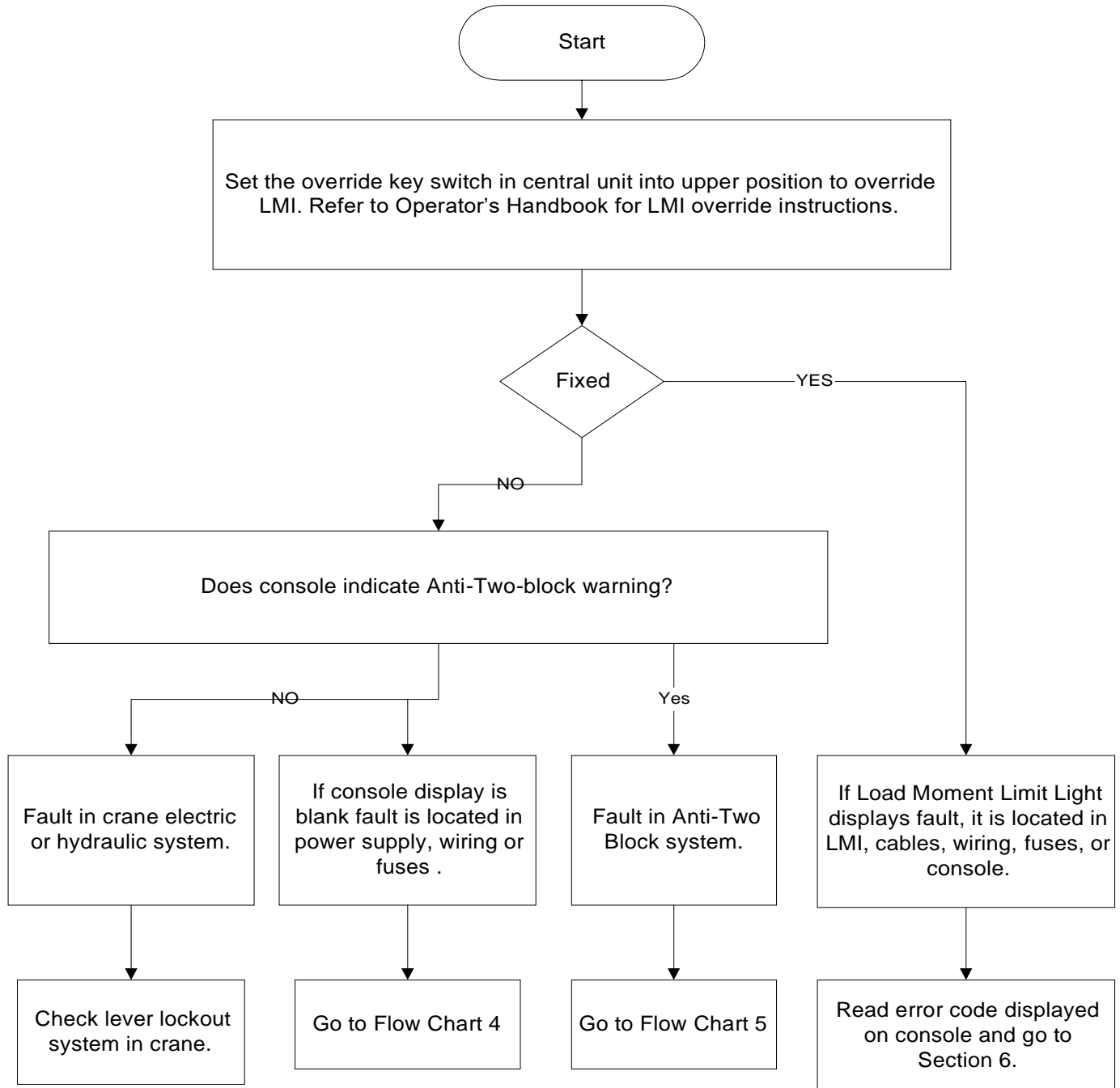

Broken Length Cable

PROBLEM: Damaged or broken length cable.

Refer to cable reel parts list and system wiring diagram.

Replace length cable using the following procedure:

- 1 Cut old cable at cable drum
- 2 Disconnect damaged length cable from junction box at the boom nose.
- 3 Open cable reel cover and disconnect wiring from connection block. Pull 7 conductor cable out of strain relief.
- 4 Remove cable reel from mounting brackets.
- 5 Remove damaged length cable, which is mounted to the slip rings in the cable reel, from slip ring connection.
- 6 On the backside of the cable reel, open the strain relief attached to the axle in the center of the drum. Pull existing length cable out of the cable reel.
- 7 Pull new length cable through the hole, pipe and strain relief and push it through the axle of the reeling drum. Tighten strain relief to ensure sealing.
- 8 Reconnect the length cable to the slip ring.
- 9 Remount cable reel to the boom.
- 10 Turn reeling drum clockwise to spool the new cable neatly onto the drum.
- 11 Set preload on cable reel by turning the drum counter-clockwise 5 to 8 turns.
- 12 Wrap the new length cable around the boom tip anchor pin (4 or 5 wraps) and secure with tie wraps. Leave enough length cable to connect into the boom tip junction box.
- 13 Connect the length cable into the boom tip junction box.
- 14 Reset length potentiometer in length angle transducer (screw is located in center of white gear); with boom fully retracted, turn potentiometer carefully counter-clockwise until it stops. Recheck length and angle display.

No Display

PROBLEM: Blank console display with no warning light shown. All crane moments have been stopped.

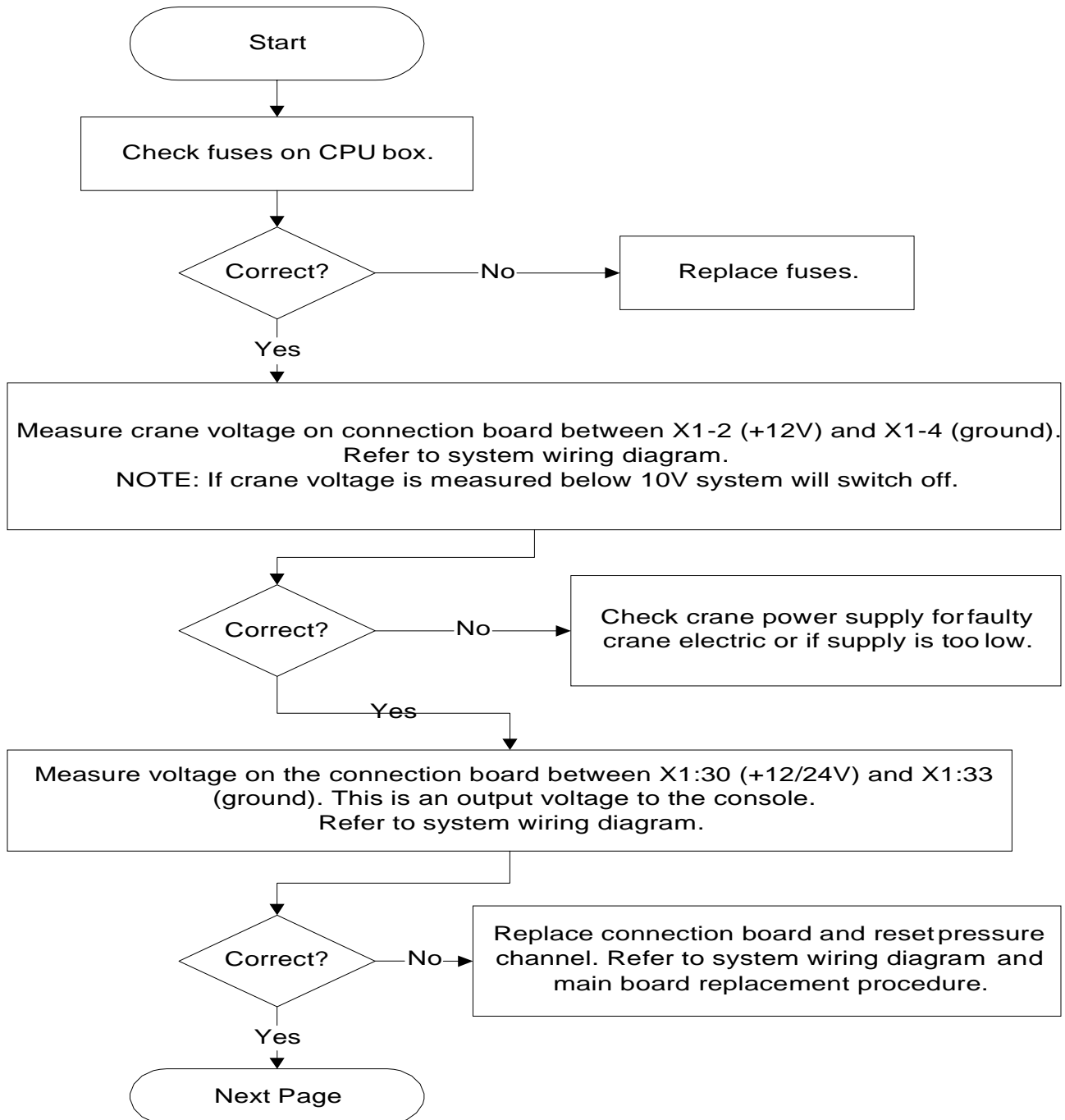

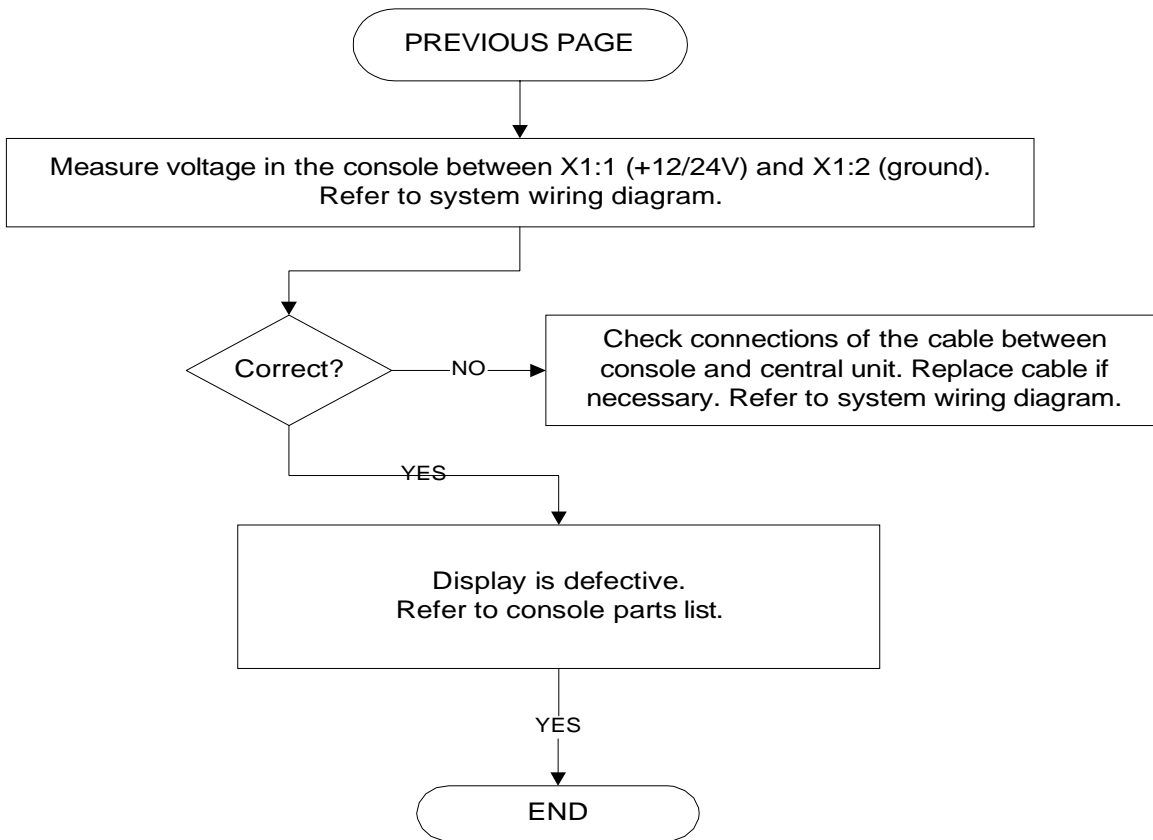

Anti Two Block Problem

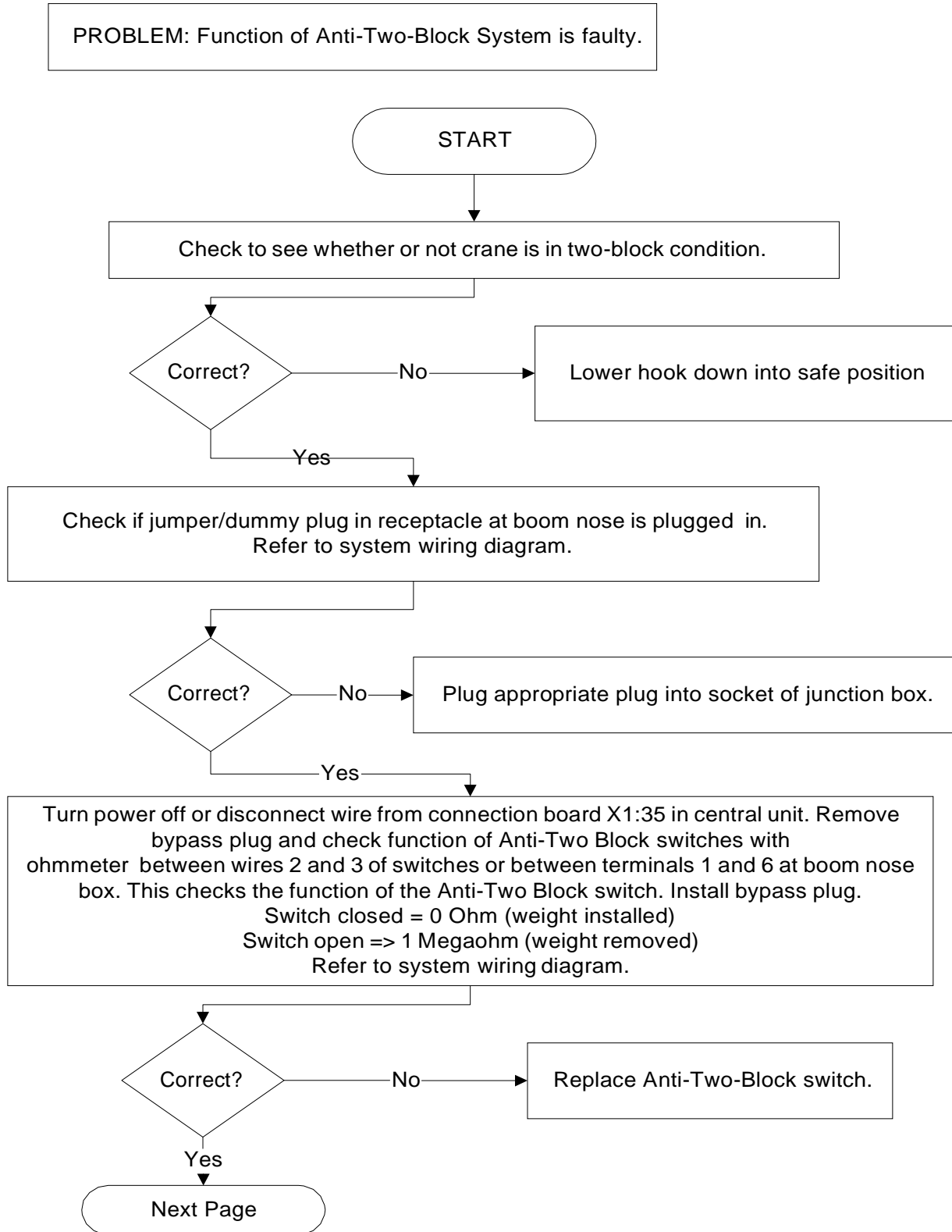

PREVIOUS PAGE

Measure the A2B signal in the cable reel between X1:Brown and X2:Red wires on the slip ring with an ohmmeter.
 Switch closed = $4700 \pm 500\text{Ohms}$
 Switch open => 1 Megaohm
 Reconnected slip ring wires.
 Refer to system wiring diagram.

Correct?

No → Fault in wiring between boom nose box and cable reel. Check for damaged length cable and wiring.
 Refer to system wiring diagram.
 If broken length cable, Refer to length cable replacement.

Measure the A2B signal in the cable reel between terminal 7 and 8 with an ohmmeter.
 Switch closed = $4700 \pm 500\text{Ohms}$
 Switch open => 1 Megaohm
 Reconnected slip ring wires.
 Refer to system wiring diagram.

Correct?

No → Replace slip ring
 Refer to cable reel parts list.

Measure the A2B signal in the boom base 10 pin receptacle between terminal 5 and 6 with an ohmmeter.
 Switch closed = $4700 \pm 500\text{Ohms}$
 Switch open => 1 Megaohm
 Reconnected slip ring wires.
 Refer to system wiring diagram.

Correct?

No → Fault in 7 conductor cable between cable reel and boom base box.
 Refer to system wiring diagram.

NEXT PAGE

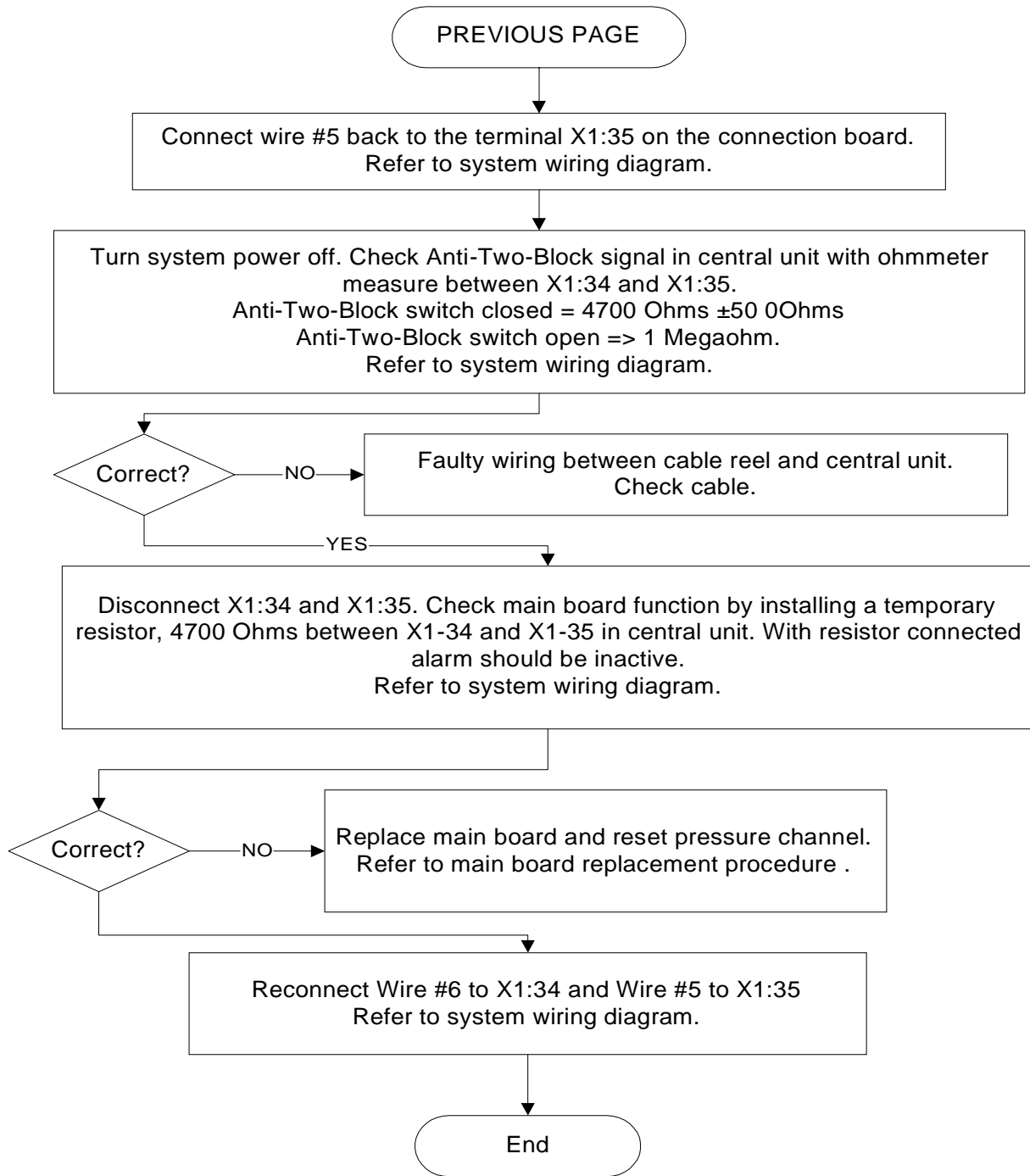

Length Reading Problem

PROBLEM: Length reading incorrect. Crane is not in "out of load chart" condition.

START

Check mechanical adjustment of length potentiometer in cable reel. When main boom is fully retracted, adjust length potentiometer counter-clockwise until it stops.
Refer to length/angle adjustments procedure.

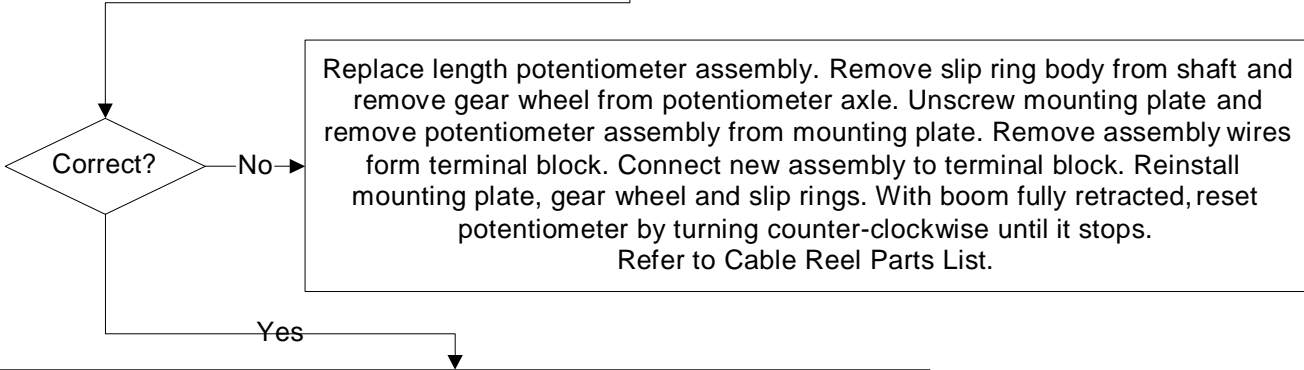

Check out clutch in big gear wheel of length transducer. Extend and retract boom to ensure that clutch is not slipping on potentiometer axle.

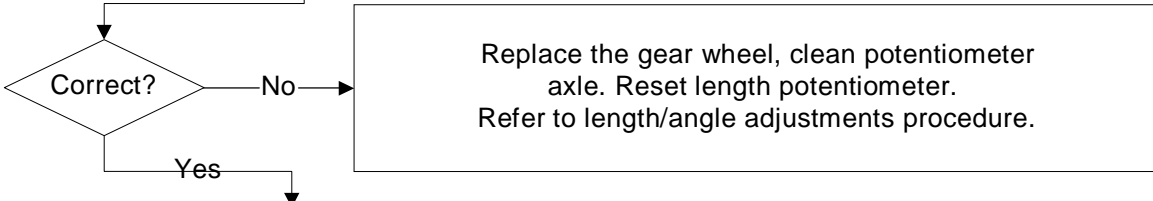

Check power supply to length transducer on connection board, terminal X1:8 (ground) and X1:11 (-5V)
Refer to system wiring diagram.

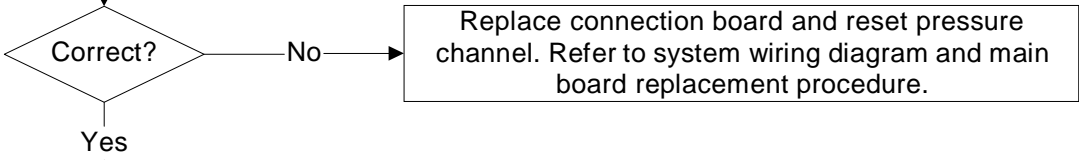

NEXT PAGE

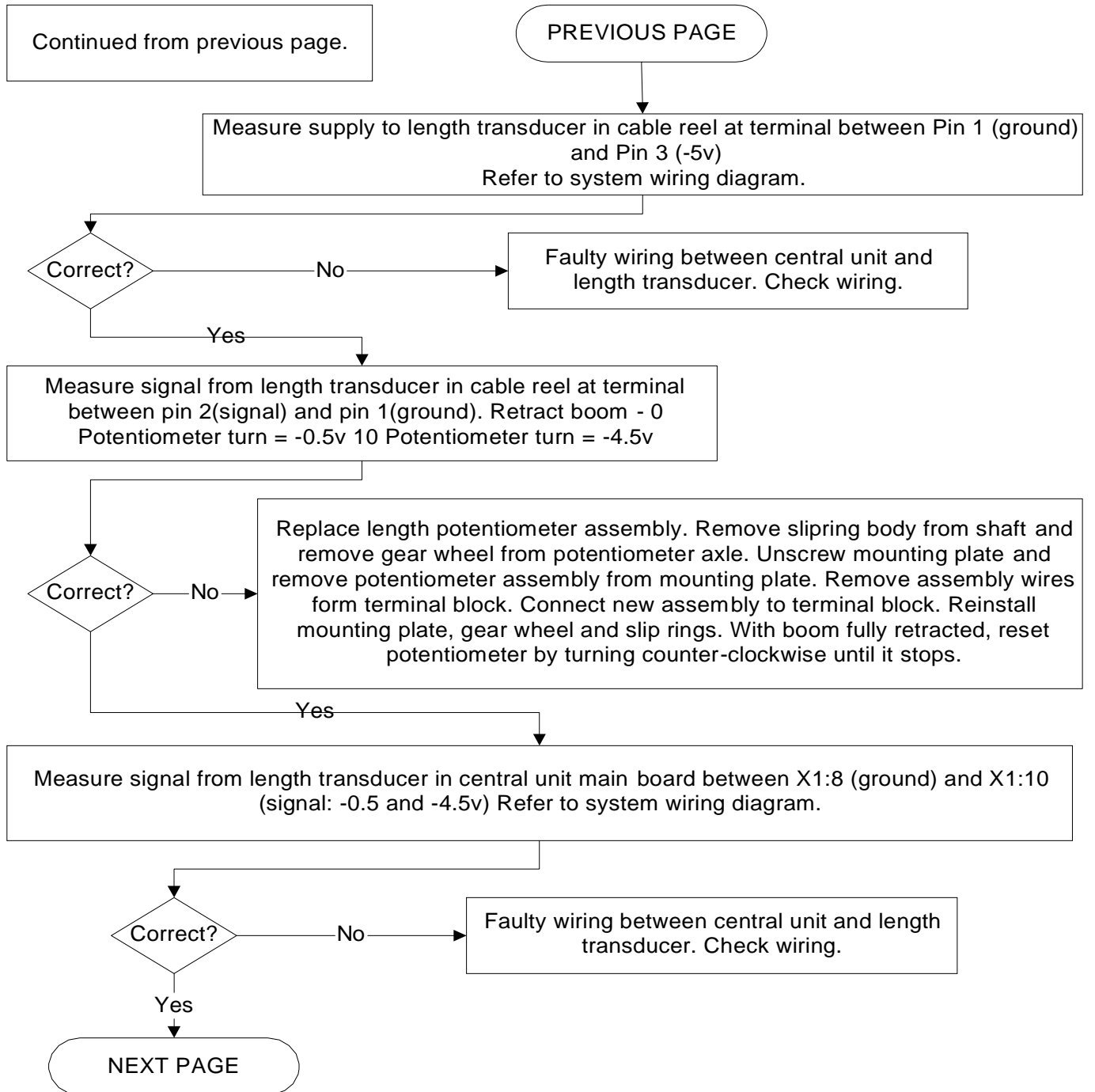

Continued from previous page.

PREVIOUS PAGE

Measure length signal of amplified output on connection board between test point MP10 and test point MP13. (+5V)
 NOTE: Negative signal at terminal X1:11 will be converted into positive signal at MP13 (i.e.: input at terminal X1:11 = -0.5V and gnd).
 Refer to system wiring diagram.

Correct?

No

Replace connection board and reset pressure channel.
 Refer to system wiring diagram and main board replacement Procedure.

Yes

END

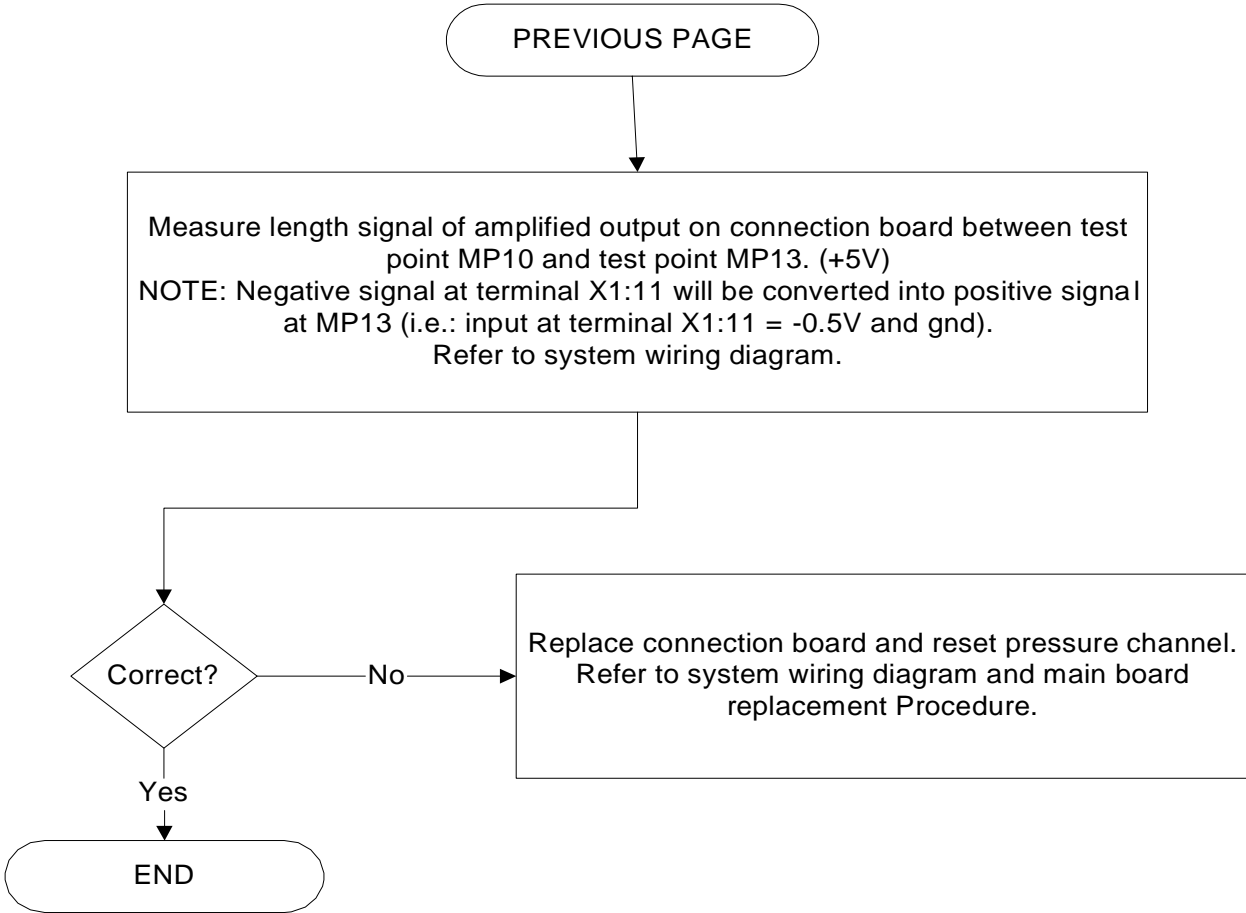

Load Reading Problem

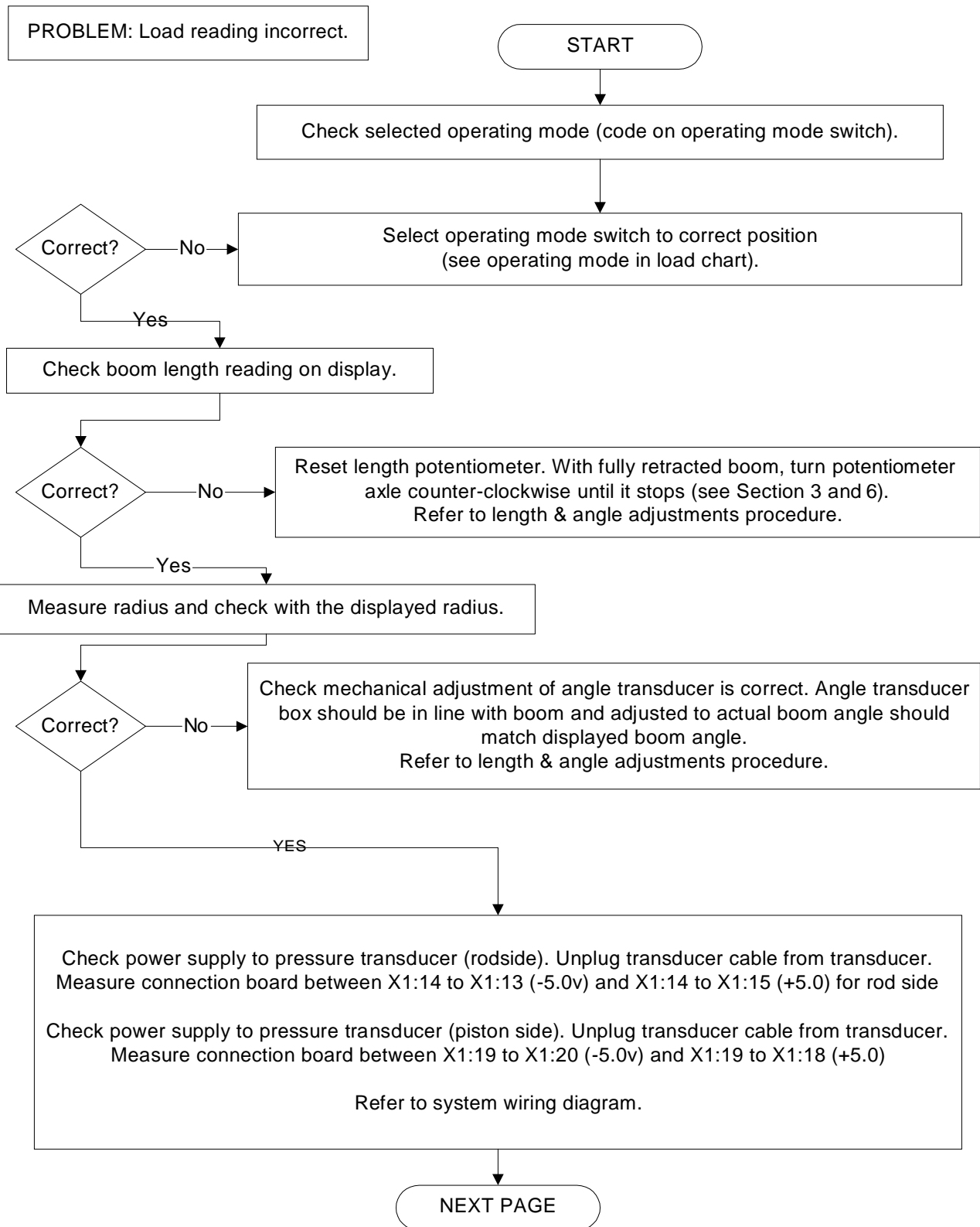

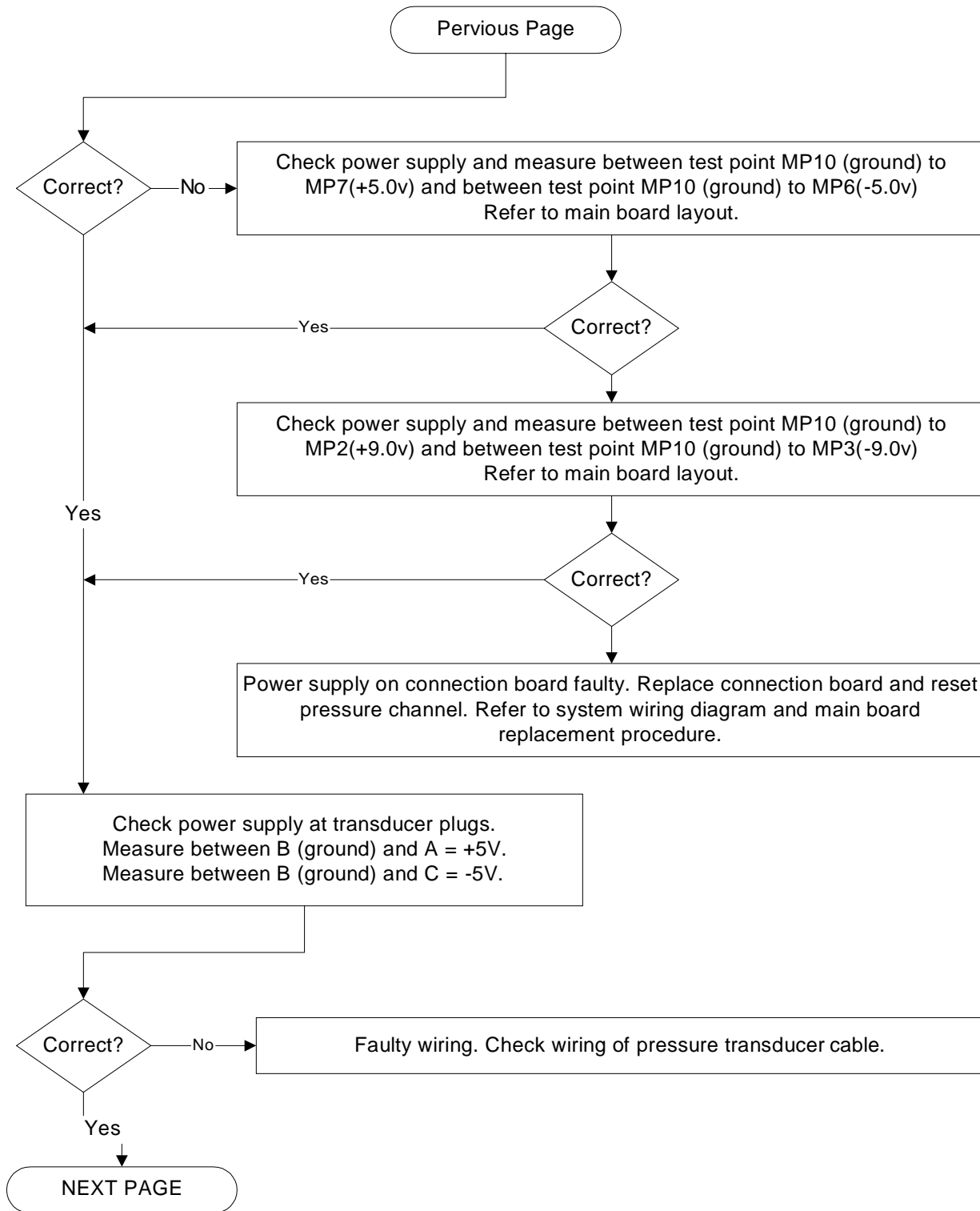

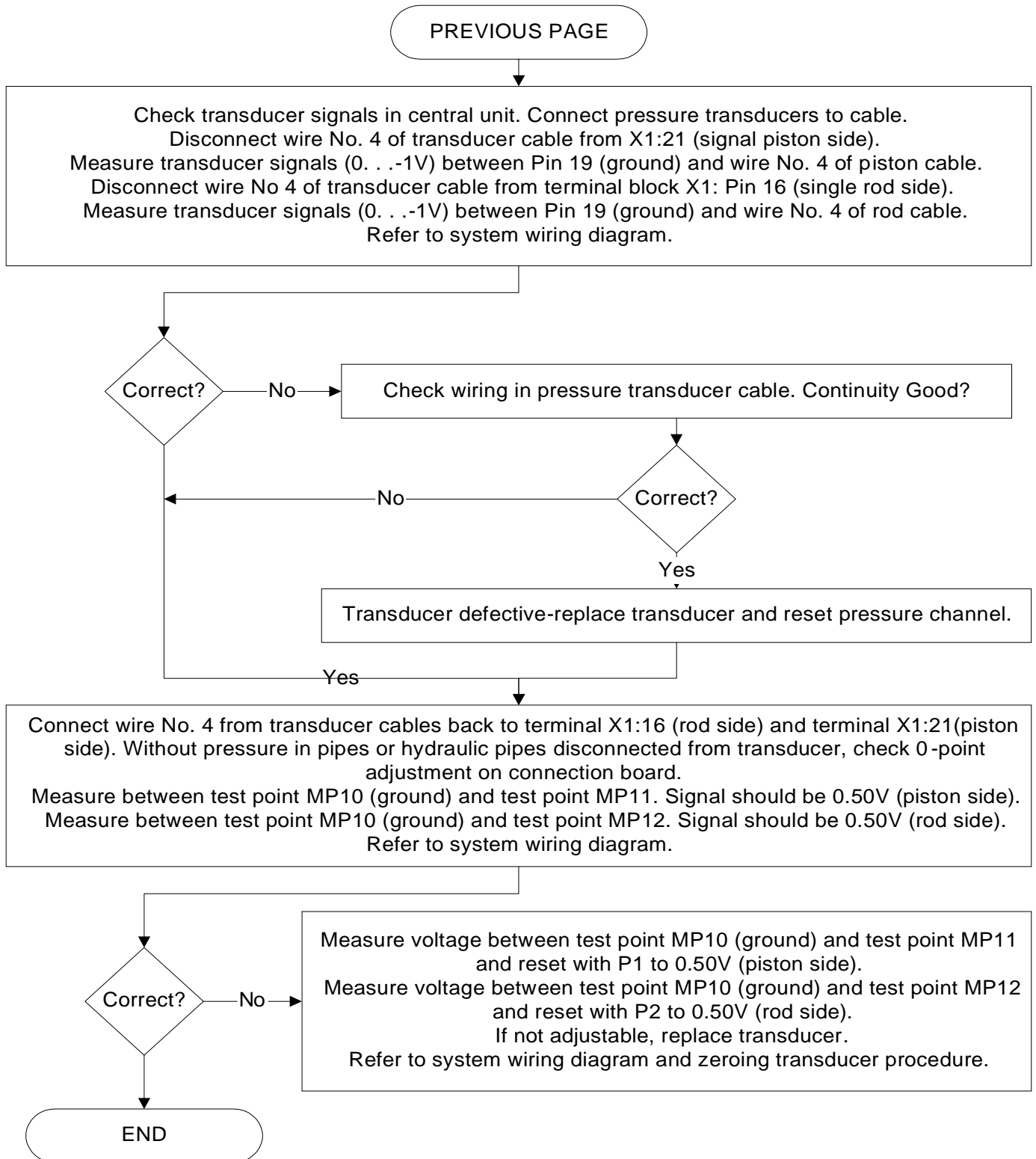

Bad Data Transfer Between Console & Central Unit

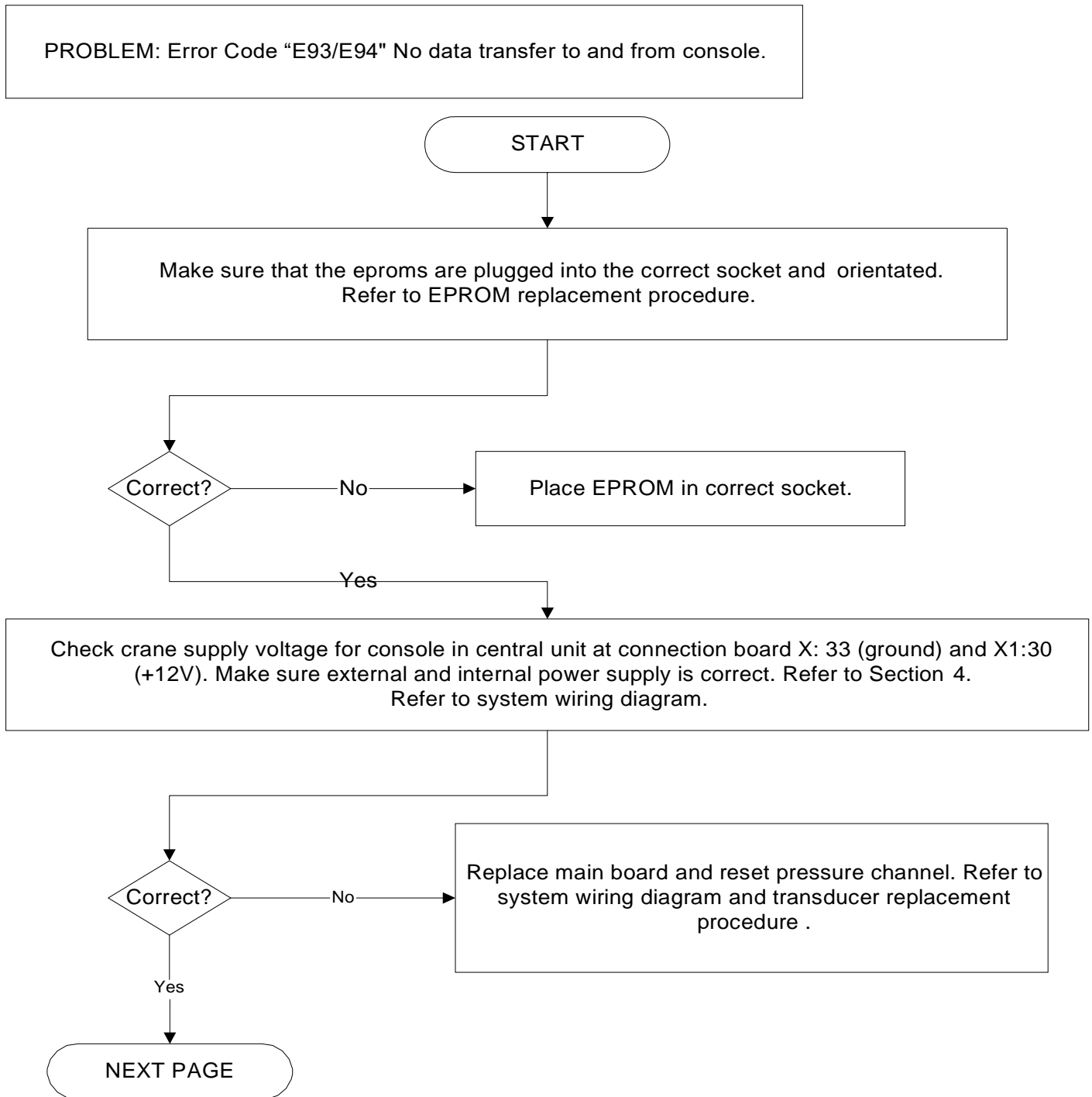

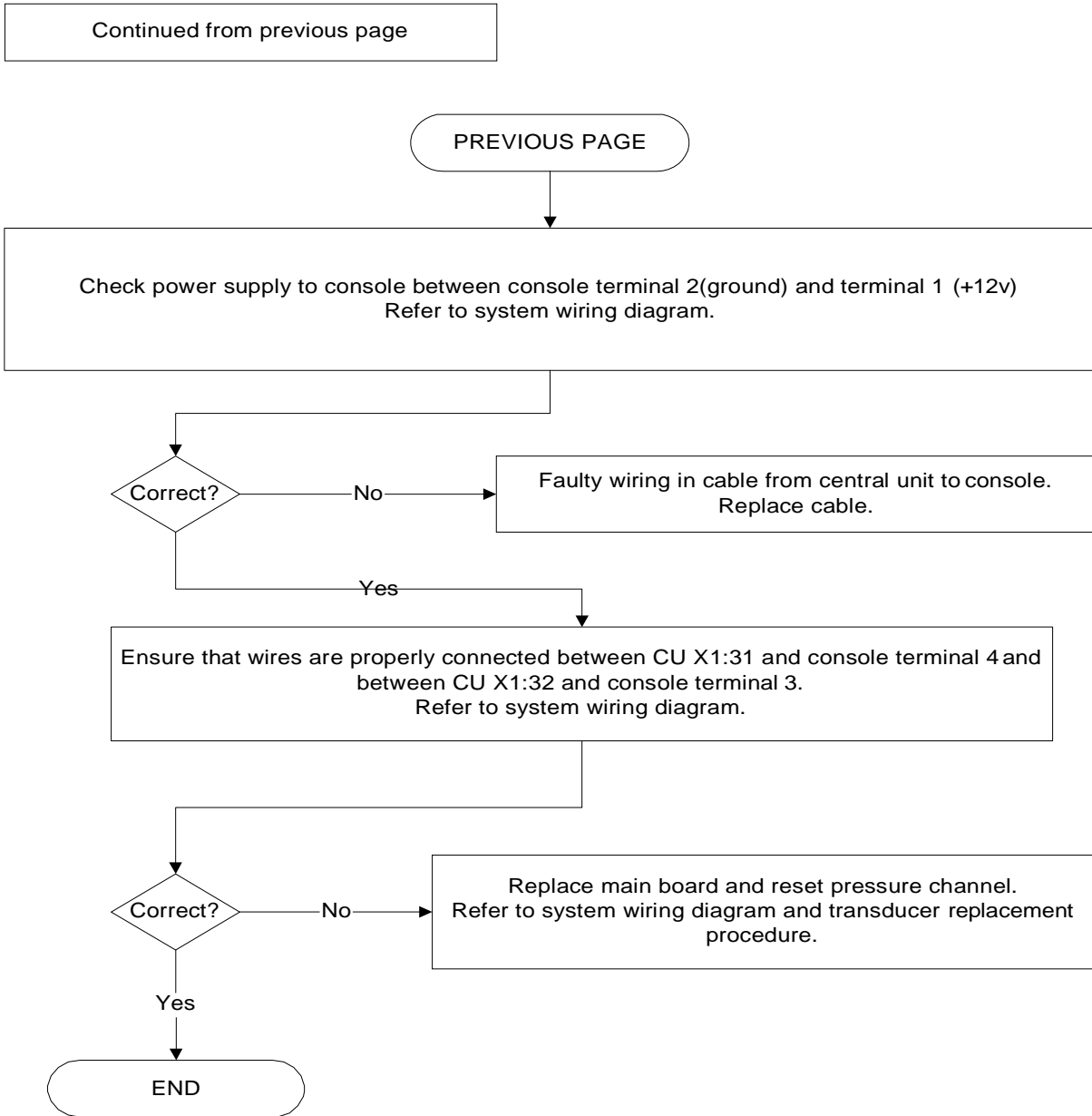

Interference Problem

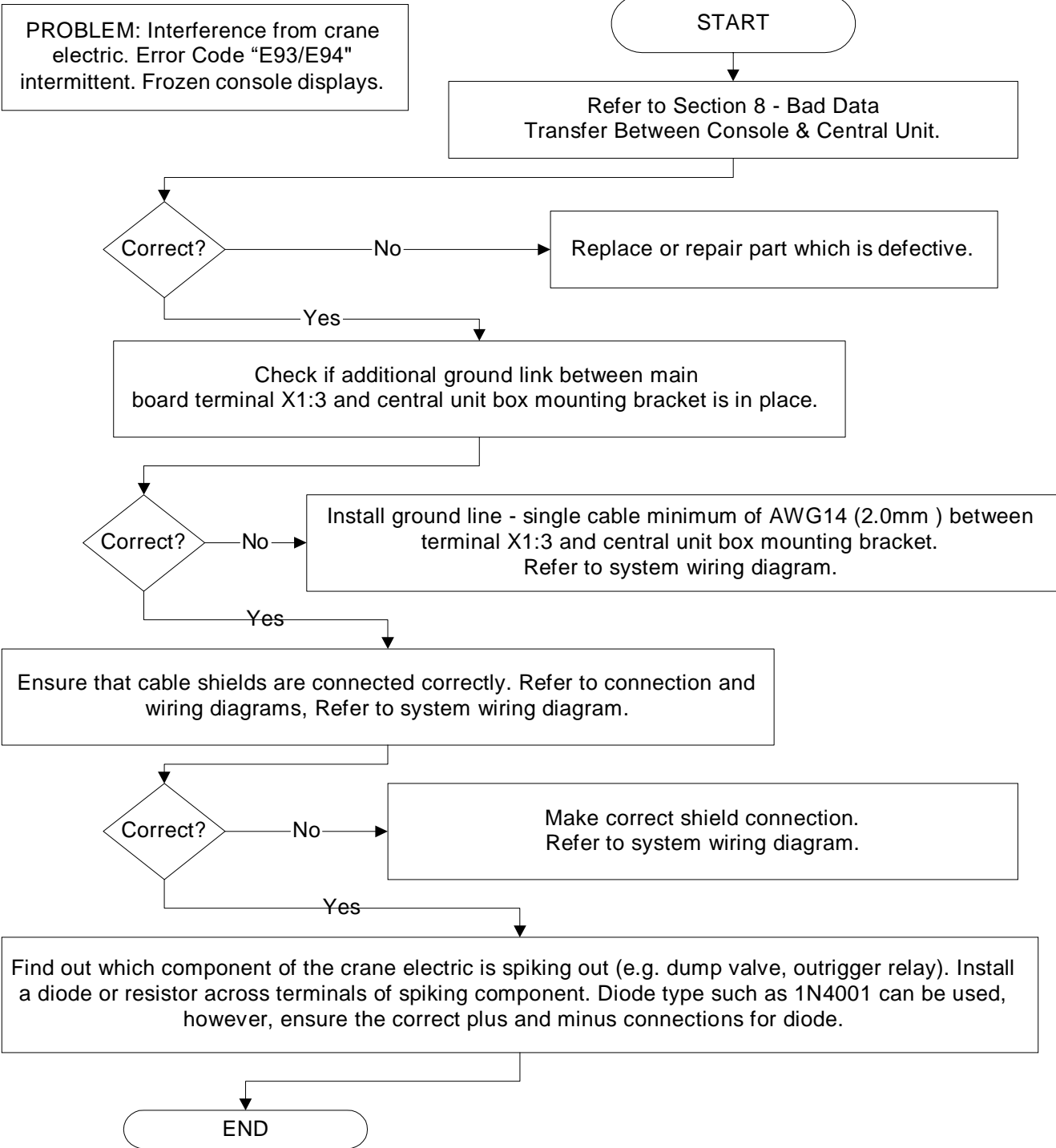

Angle Problem

PROBLEM: Displayed Angle Incorrect. Actual measured angle is different from displayed angle.

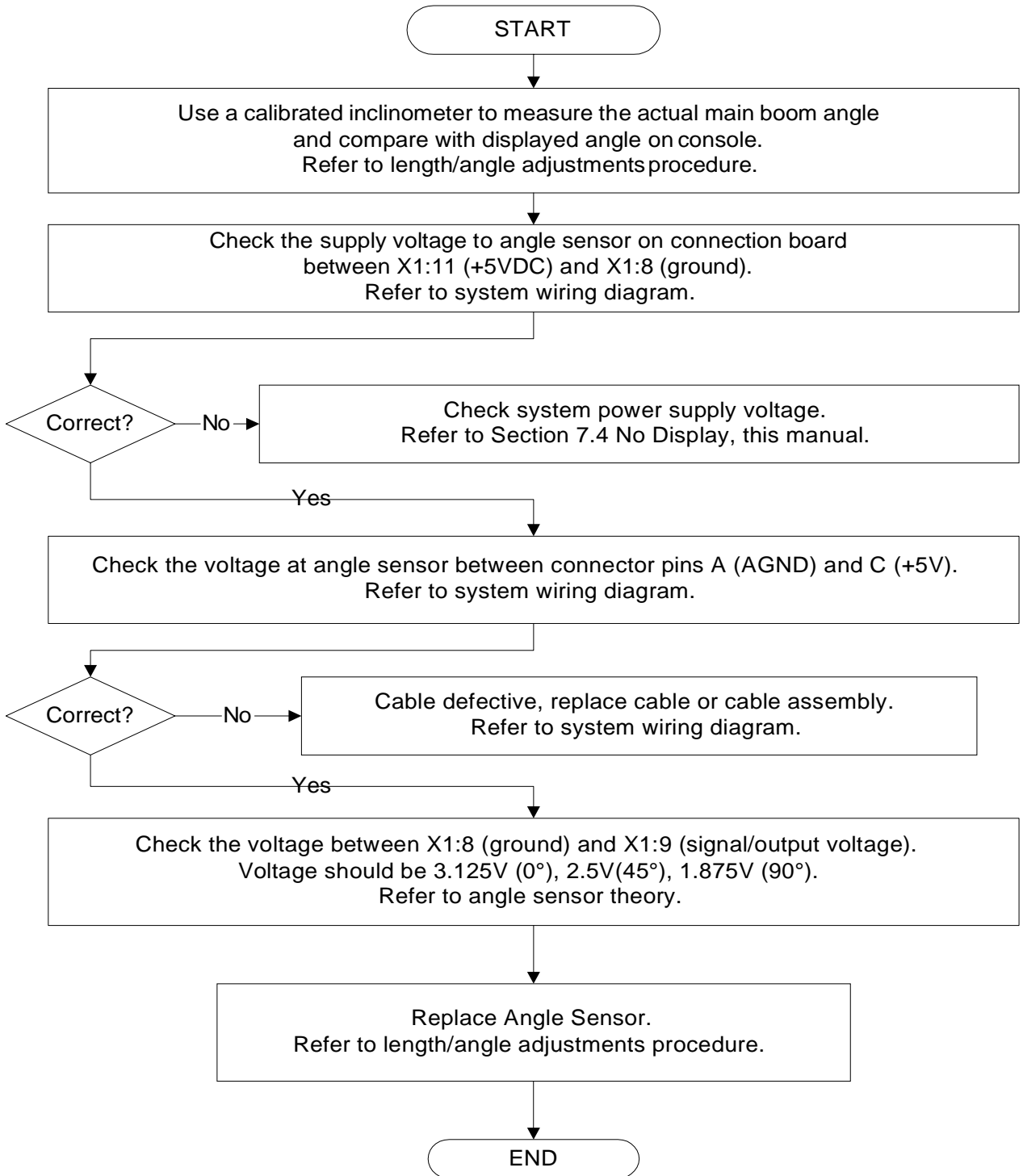

8 ERROR CODE TABLE

Error Code	Error	Cause	Elimination
E01	Fallen below radius range or angle range exceeded	<ul style="list-style-type: none"> Fallen below the minimum radius or gone past the maximum angle specified in the respective load chart due to luffing up the boom too far 	<ul style="list-style-type: none"> Luff down the boom to a radius or angle specified in the load chart.
E02	Radius range exceeded or fallen below angle range	<ul style="list-style-type: none"> Gone past the maximum radius or fallen below the minimum angle specified in the respective load chart due to luffing down the boom too far 	<ul style="list-style-type: none"> Luff up the boom to a radius or angle specified in the load chart.
E03	Non-permitted slewing zone (no load area)	<ul style="list-style-type: none"> The slewing zone with load is not permitted 	<ul style="list-style-type: none"> Slew to permitted area
E04	Operating mode not acknowledged or non permitted slewing zone	<ul style="list-style-type: none"> A non existing operating mode has been selected The boom is in a non-permitted slewing zone 	<ul style="list-style-type: none"> Set the correct operating mode for the operating state in question Slew the boom to a permitted area.
E05	Prohibited length range	<ul style="list-style-type: none"> Boom has been extended either too far or not far enough, e.g. if it is prohibited to go beyond a certain maximum boom length or with load curves for jibs where the main boom has to be extended to a certain length 	<ul style="list-style-type: none"> Extend/retract boom to the correct length
		<ul style="list-style-type: none"> Length sensor adjustment has changed, e.g. the cable slid off the length sensor reel. 	<ul style="list-style-type: none"> Retract boom. Check the pre-stress of the cable reel (cable must be taut). Open the length sensor and carefully turn the length sensor pot counter clockwise until loosened by using a screw driver

Error Code	Error	Cause	Elimination
		<ul style="list-style-type: none"> • Clutch between length sensor pot and drive is defective • Failure of +5V supply of analog part of analog board • Cable between central unit and length sensor is defective or disconnected. • Defective length potentiometer 	<ul style="list-style-type: none"> • Replace the complete clutch including drive wheel and adjust length sensor pot as described above • Check +5 V supply. Exchange main board in case of voltage failure or breakdown when loaded with 50 ohms approx. • Check cable and plugs, replace, if need be. • Replace length potentiometer.
E06	Radius range exceeded or fallen below angle range with luffing jib operation	<ul style="list-style-type: none"> • Maximum radius as specified in the load chart exceeded or fallen below minimum angle due to luffing down the luffing jib too far 	<ul style="list-style-type: none"> • Luff the jib to a radius or angle specified in the load chart.
E07	Faulty acknowledgment of the overload relay on the main board. The relay should be energized, the 2nd contact however is indicated to be off, or the 2nd contact is indicated to be on while the relay should be de-energized.	<ul style="list-style-type: none"> • Overload relay or main board are defective • Processor board defective 	<ul style="list-style-type: none"> • Replace main board • Replace processor board.
E08	No acknowledgment from the anti-t wo-block relay	<ul style="list-style-type: none"> • Refer to E07 	<ul style="list-style-type: none"> • Refer to E07

Error Code	Error	Cause	Elimination
E11	Fallen below lower limit value for measuring channel "length main boom"	<ul style="list-style-type: none"> • Cable between central unit and length sensor is defective or disconnected. Water inside the plug of the length/angle sensor • Length potentiometer is defective • Electronic component in the measuring channel is defective 	<ul style="list-style-type: none"> • Check cable as well as plugs, replace, if need be. • Replace length potentiometer • Replace LMI main board or processor board.
E12	Fallen below the lower limit value in the measuring channel "pressure piston side"	<ul style="list-style-type: none"> • Cable between the central unit and pressure transducers defective or water inside the plugs • Pressure transducer is defective. • Electronic component in the measuring channel is defective. 	<ul style="list-style-type: none"> • Check cable as well as plugs, replace, if need be. • Replace pressure transducer • Replace LMI main board or processor board.
E13	Fallen below lower limit value in the measuring channel "pressure rod side"	<ul style="list-style-type: none"> • Refer to E12 	<ul style="list-style-type: none"> • Refer to E12
E15	Fallen below lower limit value in measuring channel "angle main boom"	<ul style="list-style-type: none"> • Cable between central unit and the length/angle sensor defective or loose. Water inside the plug of the length/angle sensor. • Angle potentiometer defective • Electronic component in the measuring channel defective. 	<ul style="list-style-type: none"> • Check cable as well as plugs, replace, if need be. • Replace angle sensor • Replace LMI main board or processor board.
E16	Fallen below lower limit value in measuring channel "angle 2"	<ul style="list-style-type: none"> • Cable between the central unit and the angle sensor defective or loose. Water inside the plug of the angle sensor. • Angle potentiometer defective • Electronic component in the measuring channel defective. 	<ul style="list-style-type: none"> • Check cable as well as plugs, replace, if need be. • Replace angle sensor • Replace LMI main board or processor board.

Error Code	Error	Cause	Elimination
E19	Reference and/or supply voltage defective	<ul style="list-style-type: none"> • The supply voltage is falsified by one of the sensors (DAV, LWG) • Electronic component is defective 	<ul style="list-style-type: none"> • Check the voltages on the LMI main board. Check sensors, plugs and cable, replace, if need be. • Replace LMI main board
E20	Analog and/or supply voltage defective	<ul style="list-style-type: none"> • The analog voltage is falsified by one of the sensors • Electronic component is defective 	<ul style="list-style-type: none"> • Check the voltages on the LMI main board. Check sensors, plugs and cable, replace, if need be. • Replace LMI main board
E21	Upper limit value in measuring channel "main boom length" has been exceeded.	<ul style="list-style-type: none"> • Refer to E11 	<ul style="list-style-type: none"> • Refer to E11
E22	Upper limit value in measuring channel "pressure piston side" has been exceeded	<ul style="list-style-type: none"> • Refer to E12 	<ul style="list-style-type: none"> • Refer to E12
E23	Upper limit value in measuring channel "pressure rod side" has been exceeded.	<ul style="list-style-type: none"> • Refer to E12 	<ul style="list-style-type: none"> • Refer to E12
E25	Upper limit value in measuring channel "main boom angle" has been exceeded.	<ul style="list-style-type: none"> • Refer to E15 	<ul style="list-style-type: none"> • Refer to E15
E26	Upper limit value in measuring channel "angle 2" has been exceeded.	<ul style="list-style-type: none"> • Refer to E16 	<ul style="list-style-type: none"> • Refer to E16
E29	Reference and/or supply voltage defective.	<ul style="list-style-type: none"> • Refer to E19 	<ul style="list-style-type: none"> • Refer to E19
E31 E37	Error in the system program	<ul style="list-style-type: none"> • The system program PROM is defective. 	<ul style="list-style-type: none"> • Replace system program PROM (PROM No. 0)
E38	System program and data EPROM do not match.	<ul style="list-style-type: none"> • The system program in the LMI does not match to the programming in the data EPROM 	<ul style="list-style-type: none"> • Replace the system program PROM or the data EPROM (PROM No. 1)

Error Code	Error	Cause	Elimination
E41	Error in the internal write/read memory (RAM) of the computer component 80C537	<ul style="list-style-type: none"> • Computer component 80C537 defective • CPU module defective • Processor board defective. 	<ul style="list-style-type: none"> • Replace computer component 80C537. • Replace CPU module. • Replace processor board with CPU module.
E42	Error in the external write/read memory, 1st part (RAM)	<ul style="list-style-type: none"> • Write/read memory (CMOS RAM) or processor board defective. 	<ul style="list-style-type: none"> • Replace processor board with CPU module.
E43	Error in the external write/read memory, 2nd part (RAM)	<ul style="list-style-type: none"> • Refer to E42 	<ul style="list-style-type: none"> • Refer to E42
E45	Redundancy error in the A/D conversion	<ul style="list-style-type: none"> • The A/D converter on the processing board and the redundant A/D converter in the CPU 80C537 provide different results. 	<ul style="list-style-type: none"> • Replace processor board.
E46	Error in the A/D converter uPD 7004 of the processor board.	<ul style="list-style-type: none"> • No acknowledgment of the A/D converter uPD 7004 	<ul style="list-style-type: none"> • Replace processor board.
E48 E49	Cyclic RAM test: error in the internal write/read memory (RAM) of the computer component 80C537	<ul style="list-style-type: none"> • Computer component 80C537 defective • CPU module defective • Processor board defective. 	<ul style="list-style-type: none"> • Replace computer component 80C537. • Replace CPU module • Replace processor board with CPU module.
E51	Error in the crane data EPROM or EEPROM.	<ul style="list-style-type: none"> • No valid data in the crane data EEPROM. • Memory module wrongly bridged. • Crane data EPROM defective 	<ul style="list-style-type: none"> • Load crane data EEPROM containing valid data. • Bridge memory module acc. to memory type • Replace crane data EPROM

Error Code	Error	Cause	Elimination
E91	No data transmission from the console to the central unit	<ul style="list-style-type: none"> • 24 V supply of the console is interrupted • Interruption or accidental ground in the line between console electronics and central unit • Transmitter/receiver module is defective 	<ul style="list-style-type: none"> • Check 24 V at terminal X1 of the console electronics • Check the main console electronics - central unit. In case of an accidental ground, the transmitter module of the console electronics might be damaged. Therefore, replaces the console electronics. • Exchange console electronics or LMI main board
E92	Error in the data transmission from console to central unit	<ul style="list-style-type: none"> • Loose connection in the line between console electronics and central unit • Transmitter/receiver module is defective 	<ul style="list-style-type: none"> • Check the connection between console electronics and central unit • Exchange console electronics or LMI main board
E93	Error in the data transmission from the central unit to the console	<ul style="list-style-type: none"> • Refer to E92 	<ul style="list-style-type: none"> • Refer to E92
E94	No data transmission from the central unit to the console	<ul style="list-style-type: none"> • Interruption or accidental ground in the line central unit - console • 5 V supply of the computer in the central unit is missing • 5 V supply is too low • Transmitter/receiver module is defective • Computer module is defective • Electro-magnetic interferences (e.g. when switching contacts or valves) 	<ul style="list-style-type: none"> • Check line to the console (in case of accidental ground, replace console electronics, too). • Check connection to the power unit • Exchange the LMI main board • Replace console electronics or LMI main board • Replace processor board. • Eliminate the source of interference by inverse diodes or varistors.

Note: If an error message is displayed which is not contained in above list, please contact PAT America, Inc. service department.

ADDENDUM A BASIC ADJUSTMENT AND VOLTAGE CHECKS

MODEL: _____

S/N: _____

PAT DS150 P/N 024-150-060-002 central unit / 024-150-300-001 main board

1. Crane Supply Voltage @ X1-1 (+) & X1-4 (GND) = VDC
2. Main Board Power Supply (Reference Voltages +/- 50 MV):
 - + 9V @ Mp2 = _____ VDC Mp 10 Ground - Piston & Rod Pressure
 - 9V @ Mp3 = _____ VDC Mp 10 Ground - Piston & Rod Pressure
 - 5V @ Mp4 = _____ VDC Mp 10 Ground – TTL on Board
 - 5V @ Mp5 = _____ VDC Mp 10 Ground – Reference on Board
 - + 5V @ Mp6 = _____ VDC Mp 10 Ground – Internal on Board
 - 5V @ Mp7 = _____ VDC Mp 10 Ground – Length and Main/Jib Angle
4. Boom Length: (MP10 Ground for Meter)
 - Fully Retracted _____ Ft. _____ VDC @ X1:10 _____ DC @ MP13
 - Fully Extended _____ Ft. _____ VDC @ X1:10 _____ DC @ MP13
 - 5 Volt Reference Voltage _____ VDC @ X1:11
5. Boom Angle: (MP10 Ground for Meter)
 - Minimum Angle _____ ° _____ VDC @ X1:9 _____ VDC @ Mp14
 - Maximum Angle _____ ° _____ VDC @ X1:9 _____ VDC @ Mp14
 - 5 Volt Reference Voltage _____ VDC @ X1:11
6. Pressure Transducers: (MP10 Ground for Meter)
 - Piston Zero Point _____ VDC @ X1:21 _____ VDC @ Mp11
 - Rod Zero Point _____ VDC @ X1:16 _____ VDC @ Mp12
 - + 5 Volt Reference Voltage _____ VDC @ X1:13 & 18
 - 5 Volt Reference Voltage _____ VDC @ X1:15 & 20

ADDENDUM B Reference Tables for measuring supply and signal voltages for sensor channels

Use the table as a quick reference for measuring supply and signal voltages for the sensor channels that are specific to the error code listed.

Signal Voltage					
Error Code	Channel		Terminal Board Terminal X1		Nominal Voltage (VDC)
			Pin 'ground'	Pin 'supply'	
E11/21	2	Length	8	11	-5
E12/22	1	Pressure Piston side	19	20	-5
			19	18	+5
E13/23	0	Pressure Rod side	14	15	-5
			14	13	+5
E15/25	3	Angle Main boom	8	11	-5
E16/26	4	Angle Jib	23	25	-5

Signal Voltage						
Error Code	Channel		Terminal Board Terminal X1			Amplified Signal on main board use MP10 - GND and MP supply voltage 0.5 V
			Pin 'ground'	Pin 'supply'	Voltage (VDC)	
E11/21	2	Length	8	10	-0.5...-4.5	MP13
E12/22	0	Pressure Piston side	8	21	0...-1	MP11
E13/23	1	Pressure Rod side	8	16	0...-1	MP12
E15/25	3	Angle Main boom	8	9	-1.875...-3.125	MP14
E16/26	4	Angle Jib	8	24	-1.875...-3.125	MP15