



PSR Professional Service & Repair Inc.

Professional Service & Repair Inc. is a full-service mobile crane repair, inspection, and certification company. At Professional Service & Repair we understand the critical aspect of your crane being operational to your project schedule and budget. We will deliver world class service to have your crane operational in the minimum amount of time.

PSR is the global provider for sales, repair and installation of Load Moment Indicating (LMI) systems, Anti-Two Block Systems (A2B), and Rated Capacity Indicating systems. Please contact us with your crane repair and certification needs today.

PSR is the name businesses trust for crane repair, inspection, and certification.

Main Line: 706-718-0856

Fax: 706-569-7004

E-Mail: jeff@psrinc.biz

**P.O. Box 6506
Columbus, GA
31917-6506**

TABLE OF CONTENTS

NOTICE

1	GENERAL INFORMATION.....	1
2	WARNINGS	2
3	SYSTEM DESCRIPTION	3
	SYSTEM FUNCTION	4
	OPERATING CONSOLE.....	4
	CONTROL IDENTIFICATION.....	5
4	CONFIGURATION SETUP	10
	PILE DRIVING APPLICATION	10
	LMI SETUP PROCEDURE	10
	HOIST-IN-USE QUICK SELECTION	16
	CRAWLER POSITION QUICK SELECTION (IF APPLICABLE).....	17
5	OPERATION	18
	LIMIT SETTING.....	20
	Radius Limitation.....	21
	Tip Height Limitation	23
	Boom Angle Limitation.....	25
	INFO CRANE CONFIGURATION.....	27
	DISPLAY CONTRAST CONTROL.....	28
6	PRE-OPERATION INSPECTION AND CALIBRATION VERIFICATION	29
7	SERVICE AND MAINTENANCE.....	33
8	TROUBLESHOOTING	34
9	CALIBRATION.....	36
	GENERAL INFORMATION	36
	What must be calibrated?.....	36
	Material required for calibration:.....	36
	Calibration memory.....	36
	CALIBRATION CONFIGURATION SETUP	37
	CALIBRATION ZERO SETTINGS.....	37
	Force Sensor Adjustment	38
	Angle Sensor Adjustment	39
	CALIBRATION MODE	40
	Main Boom Calibration	41
	Jib Calibration.....	43
	Main Boom and Jib Calibration.....	45

1 GENERAL INFORMATION

The PAT Load Moment Indicator¹ (LMI) DS350 has been designed to provide the crane operator with the essential information required to operate the machine within its design parameters.

DS350 LMI basically consists of a central microprocessor unit, graphic operator's console, angle sensor, force transducer sensor, and anti-two block switches. The system operates on the principle of reference/real comparison. The real value, resulting from the load measurement is compared with the reference data, stored in the central processor memory and evaluated in the microprocessor. If non permitted conditions are approached, the DS350 LMI will warn the operator by sounding an audible alarm, lighting a warning light and locking out those functions that may aggravate or worsen the crane's condition.

The fixed data regarding the crane, such as capacity charts, boom weights, centers of gravity and dimensions are stored in memory chips in the central processor unit. This data is the reference information used to calculate the operating conditions.

The boom angle is measured by the angle sensor, mounted at the boom base. The cable reel cable serves as an electrical conductor for the anti two-block switches and force transducer signals.

The hoist load is measured by a force transducer mounted in the pendant, close to the boom tip.

The operator's console uses interactive graphic illustrations to guide the operator through the configuration setup and calibration programming, which considerably simplifies the input of operating modes as well as the setting of geometry limit values.

The configuration setup allows the operator to define the crane current configuration, which the computer uses to set the operating mode and define the limits for the crane configuration.

A calibration is required to define the load, radius, and boom angle for a specific crane configuration. The calibration adjusts boom weights, deflection, and offsets in main boom and extension configurations, which will be used to calculate the load moment to aid the operator in determining the crane limits for the specific operating configuration. Refer to chapter 9 for further information.

NOTE: The zero setting of the force transducer requires that the pendent be disconnected, so there are no external forces on the transducer.

¹ LOAD MOMENT: generally the product of a force and its moment arm; specifically, the product of the load and the load-radius. Ued in the determination of the lifting capacity of a crane

2 WARNINGS

The LMI is an operational aid that warns a crane operator of approaching overload conditions and over hoist conditions that could cause damage to equipment and personnel.

The device is not, and shall not, be a substitute for good operator judgment, experience and use of accepted safe crane operating procedures.

The responsibility for the safe crane operation shall remain with the crane operator who shall ensure that all warnings and instructions supplied are fully understood and observed.

Prior to operating the crane, the operator must carefully and thoroughly read and understand the information in this manual to ensure that he knows the operation and limitations of indicator and crane.

The use of load or angle sensor bypass plugs for pile driving applications will render the system inoperable from proper function and operation, and is not recommended. But, the option is available to prevent momentary cutout conditions due to spiking load indications that may occur or interfere with the pile driving application. After performing this application, the system must be returned to its normal working condition with all sensors connected, and bypass plug removed. The pre-operation inspection and calibration verification in SECTION 6 of this manual **MUST** be performed.

Proper functioning depends upon proper daily inspection and observance of the operating instructions set forth in this manual. Refer to Section 6. Pre-Operation Inspection and Calibration Verification of this handbook.



The LMI can only work correctly, if all adjustments have been properly set. For correct adjustment, the operator has to answer thoroughly and correctly all questions asked during the setup procedure in accordance with the real rigging state of the crane. To prevent material damage and serious or even fatal accidents, the correct adjustment of the LMI has to be ensured before starting the crane operation.

3 SYSTEM DESCRIPTION

The PAT Load Moment Indicator DS 350 consists of a central microprocessor unit, operating console, angle sensor, force transducer, and anti-two block switches.

The system operates on the principle of reference/real comparison. The real value, resulting from the load measurement is compared with the reference data, stored in the central processor memory and evaluated in the microprocessor. When limits are reached, an overload warning signal is generated at the operator's console. At the same time, the crane functions, such as hoist up and boom down, will be stopped.

The fixed data regarding the crane, such as capacity charts, boom weights, centers of gravity and dimensions are stored in memory chips in the central processor unit. This data is the reference information used to calculate the operating conditions.

The boom angle is measured by the angle sensor, mounted in the boom base. The cable reel cable serves as an electrical conductor for the anti two-block switches and force transducer signals.

The hoist load is measured by a force transducer mounted in the pendant, close to the boom tip.

The interactive user guidance considerably simplifies the input of operating modes as well as the setting of geometry limit values.

Fig. 1: Components of the LMI System PAT DS 350

1. Operator's Console
2. Central Unit
3. Cable Reel
4. Boom Angle Sensor
5. Junction Box
6. Force Transducer
7. A2B Switch

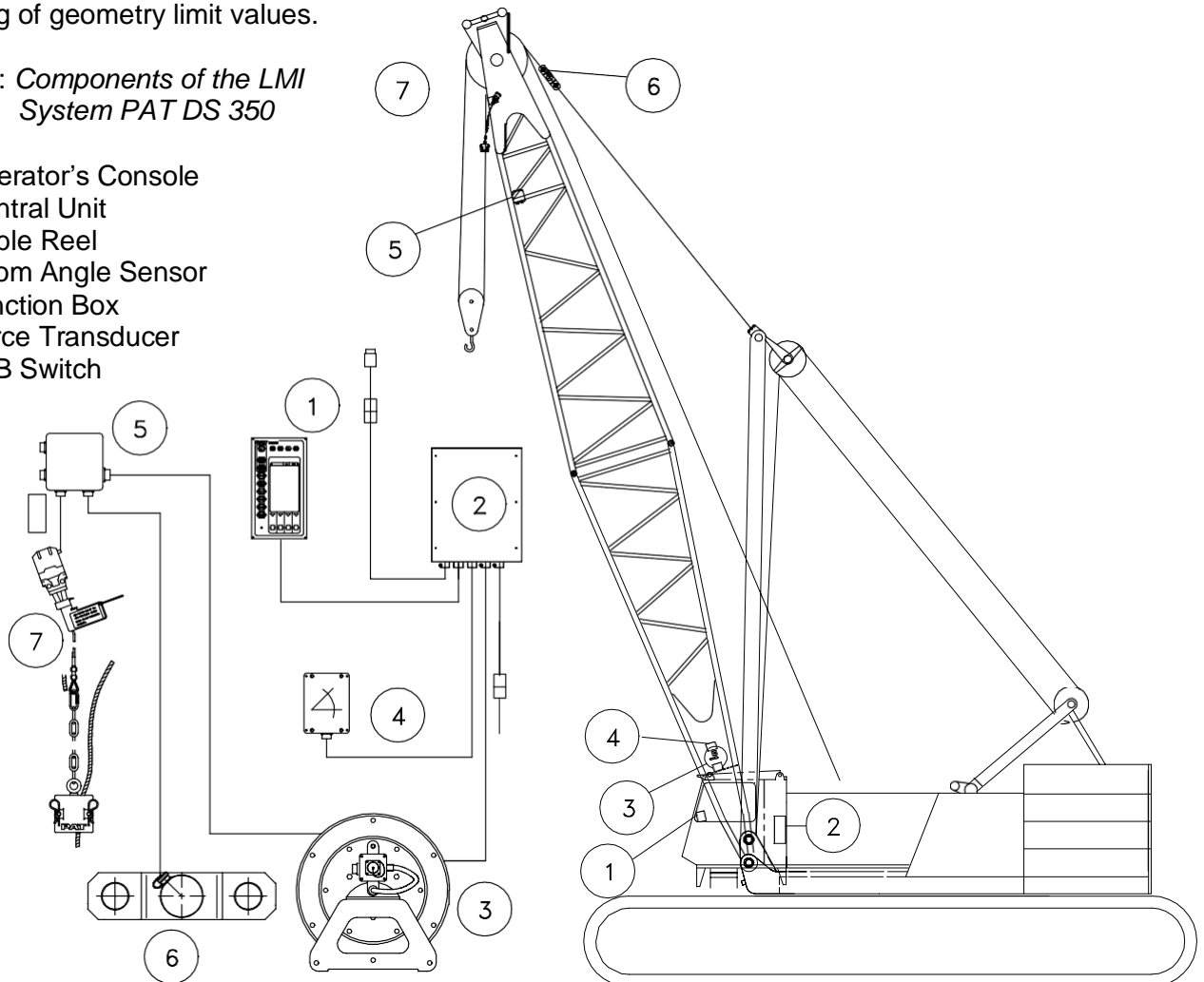

System Function

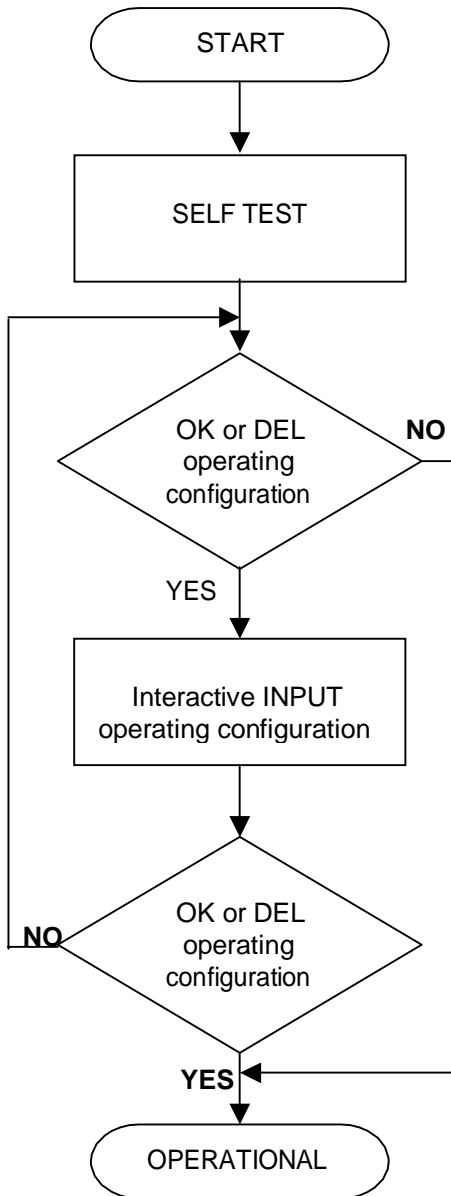

Upon switching on crane ignition switch, the system starts with an automatic test of the LMI system, of lamps and audible alarm. During the test, the LC display shows the initial logo. (approximately 35 seconds)

The previous configuration setup will be displayed showing bold symbols as selected inputs and must be confirmed OK to set the system into operation or deleted to enter a new configuration. (⇒ chapter 4)

The operating configuration is determined by an interactive step-by-step interrogation of the rigging states and reeving. (⇒ chapter 4)

The configuration setup entered will be displayed showing bold symbols as selected inputs and must be confirmed OK to set the system into operation or deleted to enter a new configuration. (⇒ chapter 4)

Upon acknowledgment of the inputs the system is ready for operation.

Operating Console

The console has 3 functions:

- inputs by the crane operator (operating configuration, reeving, and calibration)
- input of geometry limit values and signalization of exceeded limit values
- display of important data and information

The operator’s console is mounted in the crane’s cab in the operator’s field of vision. For a better identification of displays and operating elements, they are continuously backlit during operation.

Control Identification

This unit contains a display and different controls that are described as follows:

Fig 2: Operator's Console

1. LC Display Area
2. Load Moment Limit Light
3. Load Moment Prewarning Light
4. Alarm Light "Anti-Two-Block"
5. By-Pass Warning Light
6. Button "Alarm Stop"
7. Button and Control Light "TARE"
8. Button and Control Light "LIMITS"
9. Button and Control Light "SELECT OPERATION MODE"
10. Button and Control Light "INFO"
11. Button and Control Light "CONTROL"
12. Audible Alarm
13. By-Pass Key Switch
14. Button and Control Light "By-Pass Anti-Two-Block"
15. Button and Control Light "By-Pass LMI Kick-out function"
- F1. Button "Function 1"
- F2. Button "Function 2"
- F3. Button "Function 3"
- F4. Button "Function 4"

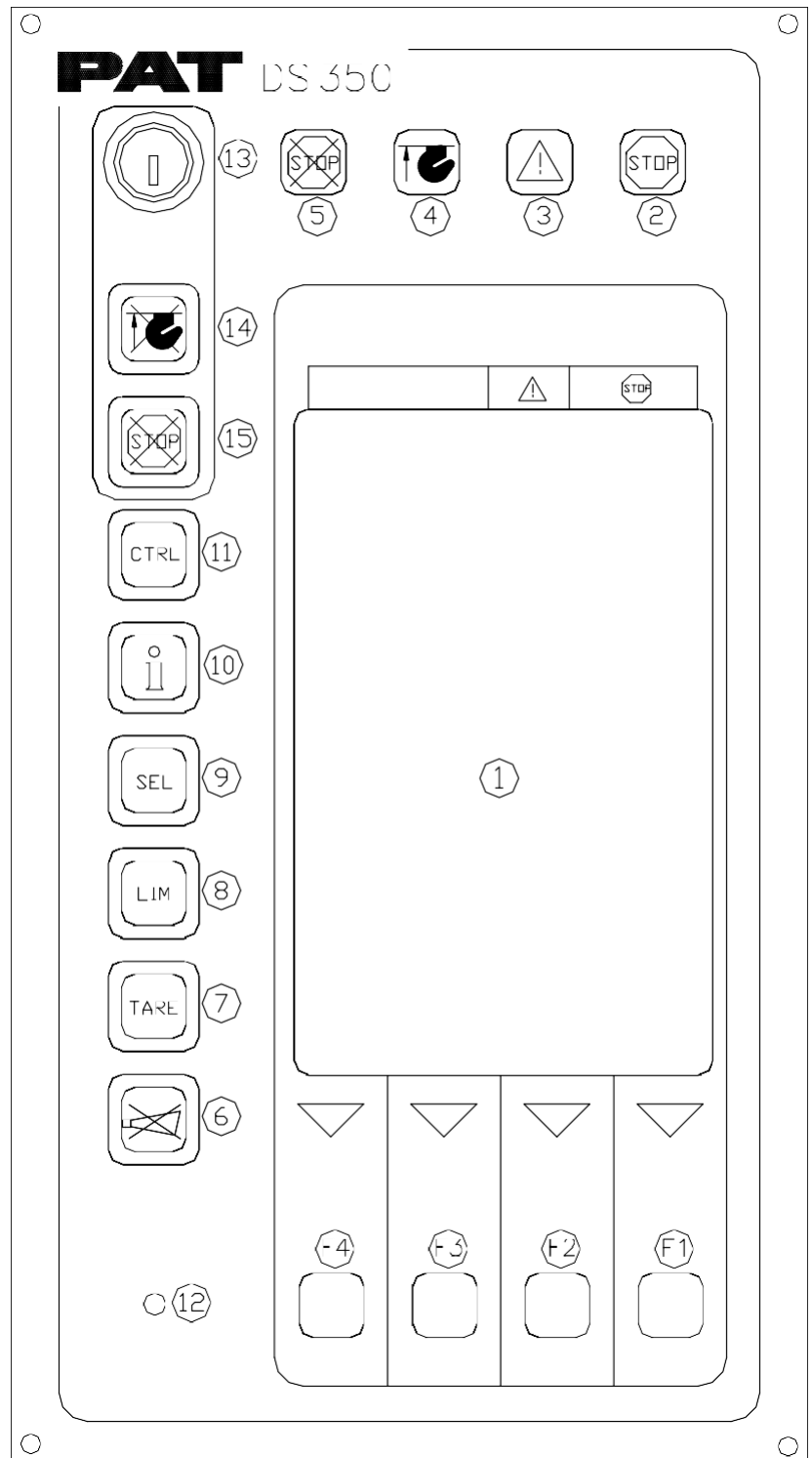

1 LC- Display

Examples:

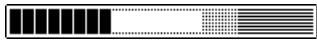

Bargraph



Anti-two Block

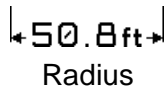

Radius

The LC display visualizes graphical symbols, texts and numerical values. Depending on the selected operating mode (setup, limit mode or LMI representation), the corresponding information is indicated on the display. Please refer to the description of the different operating modes for the signification of the individual elements. Refer to chapter 5 for complete list of symbols.

2 Load Moment Limit Light



The red LOAD MOMENT LIMIT LIGHT (2) warns the operator that a rated load condition has been reached. It lights up when the load on the crane reaches the crane load capacity. The audible alarm also sounds when this condition has been reached.

The following crane movements will be stopped concurrently:

- Hoist up
- boom down

3 Load Moment Prewarning Light



The yellow LOAD MOMENT PRE-WARNING LIGHT (3) will light up when the load on the crane reaches the defined prewarning area, thus indicating that an overload condition is approaching.

This means for the operator to continue his crane operation with extreme caution.

4 Alarm Light “Anti-2-Block”



The red “Anti Two-Block Alarm Light” (4) lights up when the anti-two-block limit switch contacts open, indicating that a two-blocking condition is approaching. At the same time the audible alarm will sound.

The following crane movements will be stopped subsequently: hoist up and boom down (depending on your machine).

5 By-Pass Key Warning Light



The red BY-PASS WARNING LIGHT (5) flashes to indicate that the kick-out function of the A2B / LMI system is deactivated.

6 Button and Control Light “Alarm Stop”

This ALARM STOP BUTTON (6) allows the audible alarm to be silenced for approximately 15 seconds by pressing this button. Reference ⇒ “Audible Alarm” (12).

7 Button and Control Light “Tare”

The button “TARE” (7) is used to indicate the “Net load” on the LC Display (1). Net load is the present load, less lifting tackle and hook block. The Tare Button (7) has to be activated *before* lifting.

After pushing the “Tare Button” (7) the load display is set to zero (taring) and the control light lights up. After lifting a load the display shows the *net load* (pay load).

The *net load* display will change to the actual load display when the boom radius is changed (either by angle or length).

8 Button “LIMITS”

Button to start the function “program limit values”.
For the proceeding please refer to ⇒ chapter 5.1.

9 Button "SELECT"



Button to start the function "set operating mode".

For the proceeding please refer to ⇒ chapter 4.1.



The correct setting is of utmost importance for the proper function of the system and the crane. Therefore only operators who are thoroughly familiar with use and operation of the system shall set this button.

10 Button "INFO"



Button to start the function "information crane configuration"

Please refer to ⇒ chapter 5.2.

11 Button "CONTROL"



Button to start additional functions.

Please refer to ⇒ chapter 5.3.

12 Audible Alarm

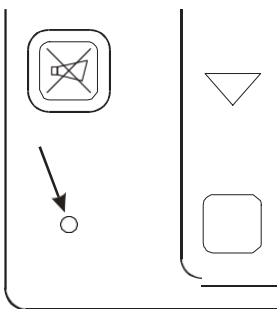

The AUDIBLE ALARM (12), sounds during the following conditions:

- overload condition
- approaching two-block condition
- preset limits reached
- malfunction of the LMI system
- operating error

The alarm can be temporarily silenced by pushing the button "Alarm Stop" (6).

13 Key Switch

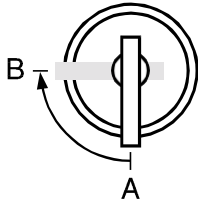

- The anti-two-block switch kick-out function is deactivated when the KEY SWITCH (13) is turned to position "B" and the "By-pass A2B" button (14) is pushed.

Or

- The LMI kick-out function is deactivated when the KEY SWITCH (13) is turned to position "B" and the "By-pass LMI" button (15) is pushed.

KEY SWITCH (13) can be operated only by using the matching button.

! WARNING

Since button (14) and (15) deactivate the kick-out function of the LMI system / the anti two-block system, the following instructions must be obeyed:

- The by-pass function shall be used with discretion, as unwarranted use of it to override the control lever lock out system can result in harm to the crane and danger to property and persons.
- Never use the by-pass function to either overload or operate the crane in a non-permissible range.

14 Button "By-pass A2B"



This button can be operated only if key switch (13) is turned to position B. While pushing this button, the kick-out function of the anti-two-block switch is deactivated. The By-Pass Warning Light (5) flashes to indicate that the kick-out function is deactivated.

15 Button "By-pass LMI"



This button can be operated only if key switch (13) is turned to position B. While pushing this button, the control lever lockout function of the LMI is deactivated. The By-Pass Warning Light (5) flashes to indicate that the kick-out function is deactivated.

4 CONFIGURATION SETUP

The LMI setup procedure allows the operator to input the crane configuration using interactive displays. The operator must complete the configuration setup procedure for the Load Moment Indicator system by confirming (pressing OK) to set the system into operation or deleted (pressing DEL) to enter a new configuration. The previous configuration setup will be displayed shown in bold symbols and must match the current crane operating configuration.

Pile Driving Application



The use of load or angle sensor bypass plugs for pile driving applications will render the system inoperable from proper function and operation, and is not recommended. But, the option is available to prevent momentary cutout conditions due to spiking load indications that may occur or interfere with the pile driving application. After performing this application, the system must be returned to its normal working condition with all sensors connected, and bypass plug removed. The pre-operation inspection and calibration verification in SECTION 6 of this manual **MUST** be performed.

To prevent momentary cutout conditions due to spiking load indications that may occur or interfere with the pile driving application, electrically disconnect the force transducer from the junction box and install the bypass connector F9L0050 (031-300-060-252) in it's place. Remove the force transducer and replace with link J5M0216 in main pendant to replace the length of force transducer.

LMI Setup Procedure

...starts:

- *manually* after each modification of the crane configuration by pressing "SEL" (9) button.



...is operated:

- by answering the different questions using functional buttons F1...F4 in accordance with the actual configuration of the crane.

...is cancelled:

- any time by pressing again the "SEL" (9) button. The system, however, is only ready for operation, if the procedure has been completed and the selections have been confirmed.

During the programming procedure the Load Moment Prewarning Light (3) and the Load Moment Limit Light (2) will light up and the crane functions will be interrupted.



The correct setting is of utmost importance for the proper functioning of the system and the crane. Therefore, only operators who are thoroughly familiar with the crane and the operation of the system should execute the setting of the system according to the operating configuration of the crane.

The LMI programming procedure consists of the following steps:

- setting the boom type configuration
- setting the counterweight configuration
- setting lower configuration
- specify boom / setting the hoist configuration and reevings
- selecting the pick point
- confirmation of the programming procedure

For easy operation, the computer guides the operator through the procedure step by step. (interactive operation)

Definition of the Displayed Symbols:

The following illustrations define the symbols appearing on the display during the setup procedure for your crane. Not all symbols will be shown, depending on the crane model and the answers to the questions.

- Setting the boom type configuration

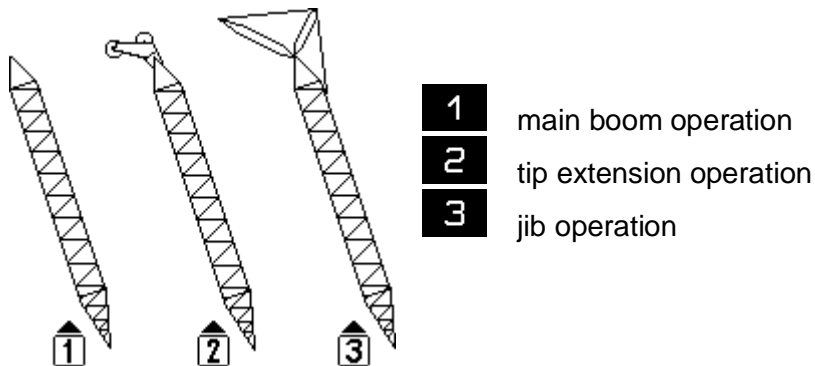

• **Setting the crawler / counterweight configuration**

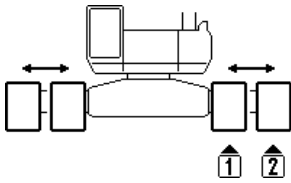

- 1** Retracted crawlers
- 2** Extended crawlers

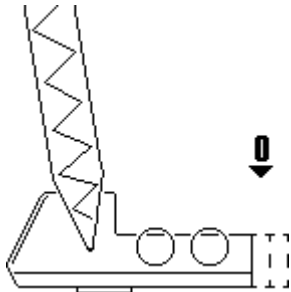

- +** increase counterweight
- OK** confirm counterweight

Note: *During the programming procedure this picture may be skipped depending on previous selection (i.e. boom selection or crawler position)*

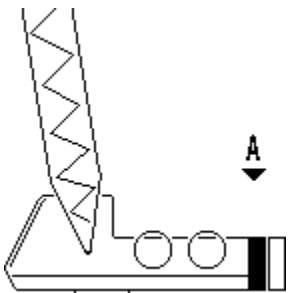

- decrease counterweight
- +** increase counterweight
- OK** confirm counterweight

Note: *During the programming procedure this picture may be skipped depending on previous selection (i.e. boom selection or crawler position)*

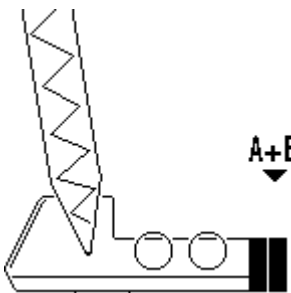

- decrease counterweight
- +** increase counterweight
- OK** confirm counterweight

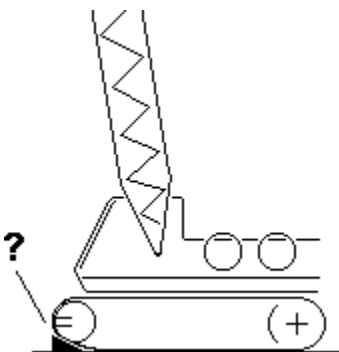

- Y** with additional over end block
- N** without additional over end block

• Specify boom / jib lengths (example jib):

Select jib length:

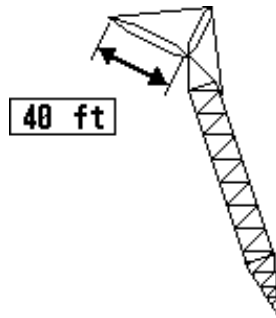

- decrease jib length
- +** increase jib length
- OK** confirm jib length selection

Select jib offset:

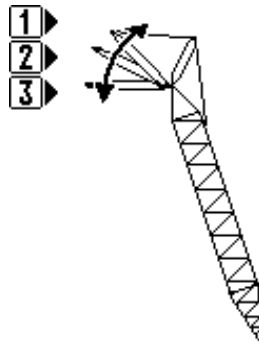

- 1** 5° jib offset
- 2** 17.5° jib offset
- 3** 30° jib offset

Select main boom length:

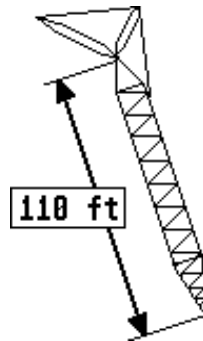

- +** increase main boom length
- decrease main boom length
- OK** confirm main boom length selection

Setting the hoist configuration and reeving (example jib)

Set front hoist drum pick point:

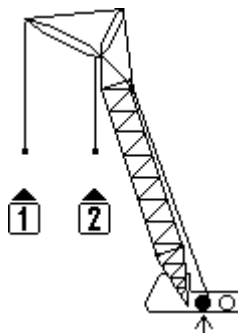

- 1** select pick point 1
- 2** select pick point 2
- N** no use of front hoist drum

Select front hoist reeving:

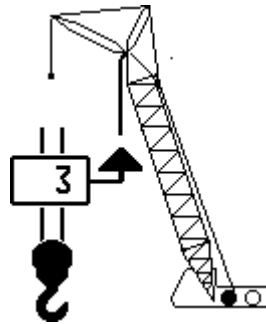

- decrease reeving
- +** increase reeving
- OK** confirm reeving

Note: During the programming procedure this picture may be skipped depending on previous selection (i.e. front hoist not used)

Set rear hoist drum pick point:

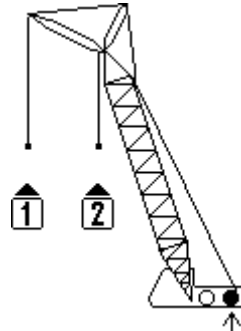

- 1** select pick point 1
- 2** select pick point 2
- N** no use of rear hoist drum

Select rear hoist reeving:

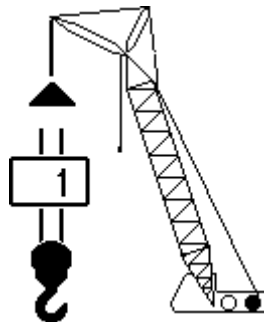

- decrease reeving
- +** increase reeving
- OK** confirm reeving

Note: During the programming procedure this picture may be skipped depending on previous selection (i.e. rear hoist not used)

Once you have set the pick-points, you can switch between them by selecting which hoist drum is in use:

- **Select hoist-in-use (example jib)**

Hoist-in-use selection:

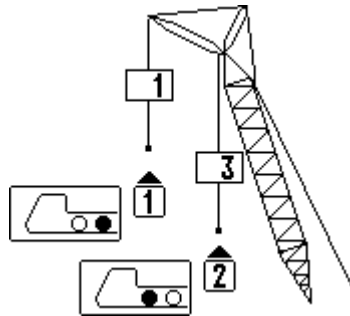

- 1** use pick point 1 as defined above
- 2** use pick point 2 as defined above

Under each pick point that you had set, you will find a symbol of the crane with the corresponding hoist drum filled in black.

Confirmation of the programming procedure

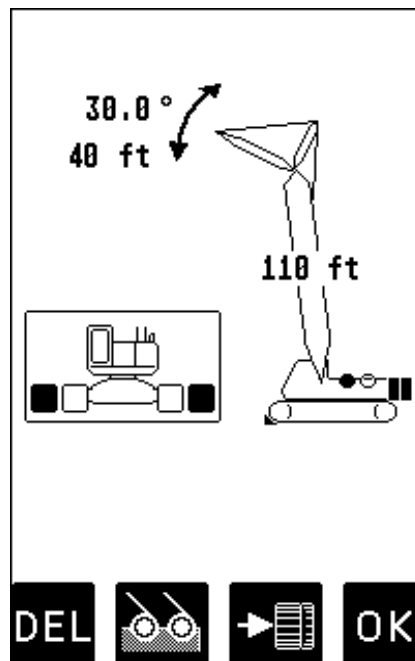

At the end of the procedure all selections are represented once again in symbolic forms. If selections have been made, the corresponding symbols are filled black (i.e. hoist drums).



Hoist-in-use quick selection
(⇒ chapter 4.2)



cancel procedure



crawler position quick selection
(⇒ chapter 4.3)



confirm inputs

Hoist-in-use quick selection

If, during the crane operation, the crane is switched over from using one hoist drum to the other, i.e. from front to rear hoist drum, the LMI system has to be adjusted to this modification. This modification can be entered without having to go through the whole LMI setup procedure again:



Call LMI setup procedure.

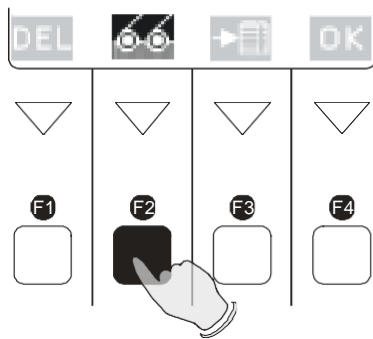

Directly call function "Hoist-in-use quick selection".

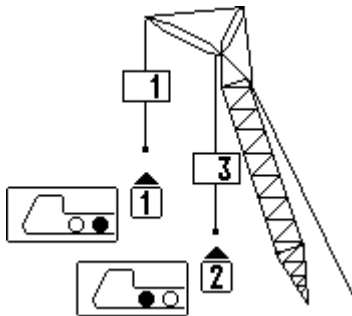

Select hoist in use (example):

- 1** use pick point 1 as defined
- 2** use pick point 2 as defined

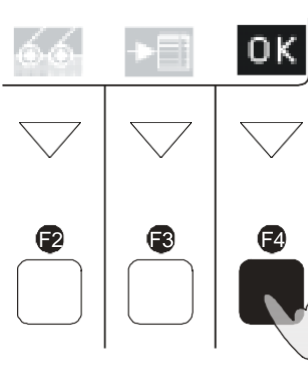

Confirm modification.

(call up the function again if you have selected the wrong hoist drum by mistake)

Crawler Position Quick Selection (if applicable)

If, during the crane operation, the position of the crawler tracks is changed, the LMI system has to be adjusted to this modification. The input of the crawler tracks position can be carried out directly without having to go through the whole LMI programming procedure again:

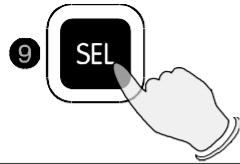

Call LMI Programming Procedure.

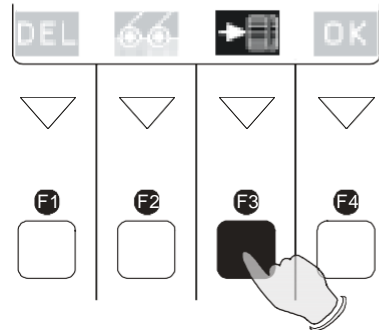

Directly call function "Crawler Position Quick Selection".

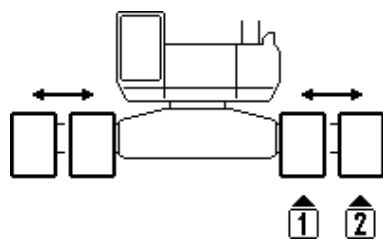

input of crawler position:

- 1** retracted crawlers
- 2** extended crawlers

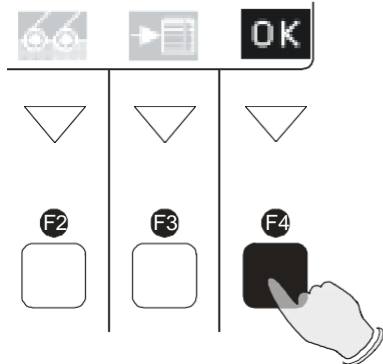

Confirm modification.

(select again the function if you made a wrong selection)

5 OPERATION

After having set the LMI to the actual crane configuration, the system is ready for operation. The display shows the LMI screen (example for value representation). This example shows a typical operating screen for a crane with a "main boom" or "main boom with jib" configuration:

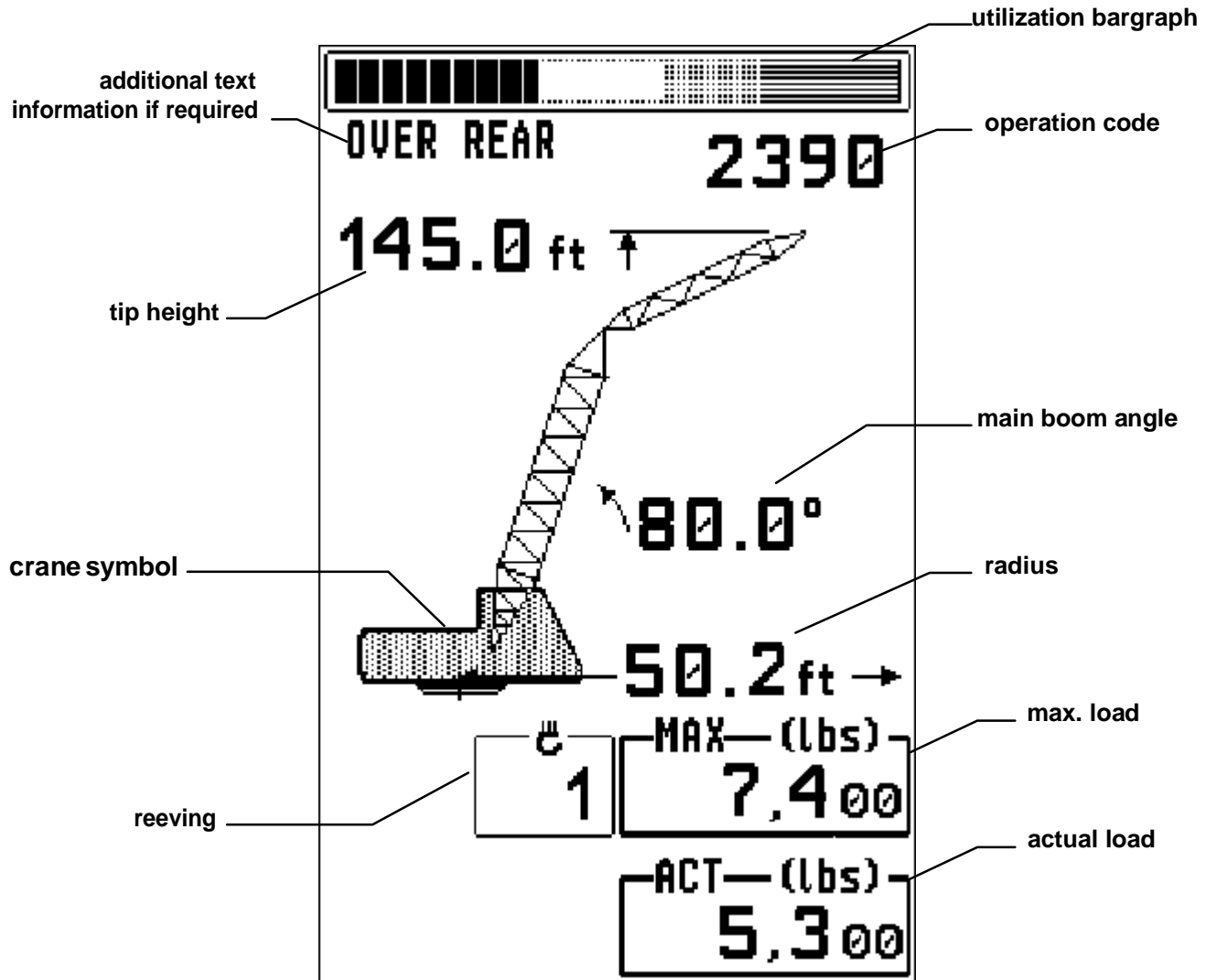

Please note that the crane symbol does not reflect the crane configuration that has been selected. To see the selected crane configuration, push the "INFO" Button (Please refer to ⇒ chapter 5.2.)

As needed, further symbols can show on the display:

	<p>Symbol Anti Two-Block Alarm visible when the anti-two-block limit switch contacts open, indicating that a two-blocking condition is approaching.</p>
	<p>Symbol height limitation: continuously visible: <i>height limitation active</i> blinking: <i>height limit exceeded</i> (⇒ see chapter 5.1.2)</p>
	<p>Symbol boom angle limitation: continuously visible: <i>boom angle limitation active</i> blinking: <i>Boom angle limits exceeded</i> (⇒ see chapter 5.1.3)</p>
	<p>Symbol radius limitation continuously visible: <i>radius limitation active</i> blinking: <i>Radius limits exceeded</i> (⇒ see chapter 5.1.4)</p>
E####	<p>Error code No. #### (⇒ see chapter 8 “Troubleshooting”)</p>

LIMIT Setting

The LMI system has been equipped with programmable limits for the crane's operation range.

- Easy programming due to interactive, step-by-step user guidance
- Functions can be used individually or in combinations.
- Exceeding a programmed limit triggers an audible and visual alarm.
- Depending on the crane type not all functions listed below may be available.
- The functions provide an audio-visual alarm when set limits are reached. They do not provide any function-kick-outs!

Overview limits:

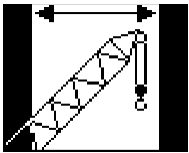

Radius Limitation

(⇒ chapter 5.1.1)

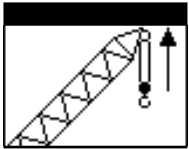

Tip Height Limitation

(⇒ chapter 5.1.2)

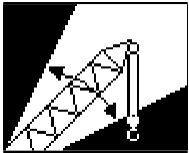

Boom Angle Limitation

(⇒ chapter 5.1.3)

R adius Limitation

This function allows the operator to program an audible and visual alarm for the limitation of a minimum and/or maximum working radius.

➡ To set / delete radius limit:

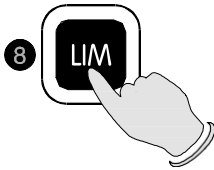

Call LIMIT Setting

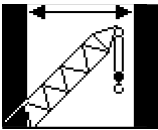

Select the corresponding symbol to call the function "Radius Limitation".

Screen will now show:

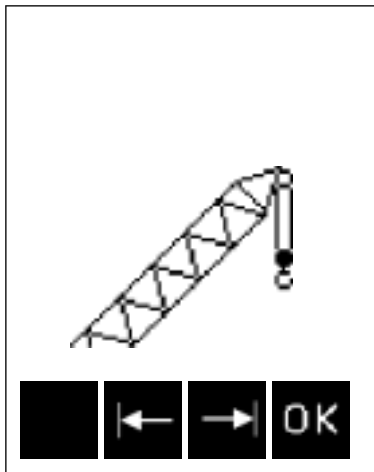

You have the choice to:

- Set a minimum radius limit:
- Set a maximum radius limit:
- Exit the function without any changes:

If a limit has already been set, it will be shown as blacked-out area with the set value(s) for radius limit:

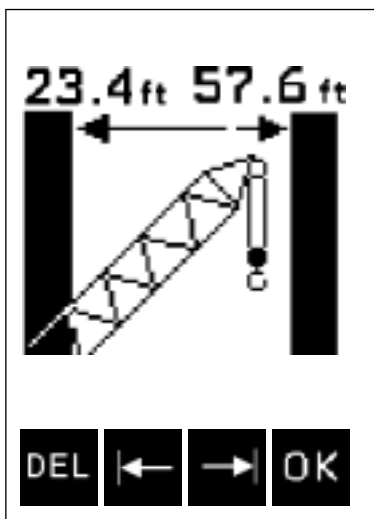

You have the choice to:

- Change the minimum radius limit:
- Change the maximum radius limit:
- Exit the function without any changes:
- Delete the radius limits and exit the function:

➡ To set / delete minimum radius limit:

Screen shows (with current radius value):

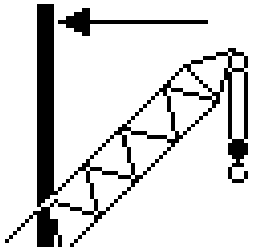

To set:

Position boom at the desired minimum radius.

Push **SET** to set current working radius as minimum radius limit.

To delete:

Push **DEL** to delete minimum radius limit and exit the function.

This takes you back to the previous screen, "Set / Delete Radius Limits":

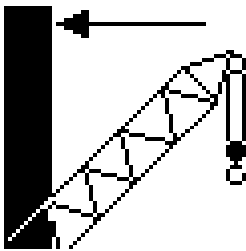

Screen now shows symbol with a black bar to the left and the set value for min. radius limit, if you have set one.

(If you did not set a minimum radius limit, there will be no left black bar and no radius value displayed).

Pushing **OK** will accept setting and quit function.

➡ To set / delete maximum radius limit:

Screen shows (with current radius value):

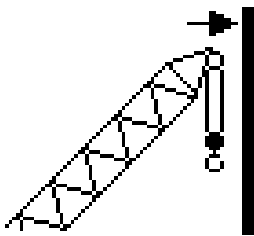

To set:

Position boom at the desired maximum radius.

Push **SET** to set current working radius as maximum radius limit.

To delete:

Push **DEL** to delete maximum radius limit and exit the function.

This takes you back to the previous screen, "Set / Delete Radius Limits".

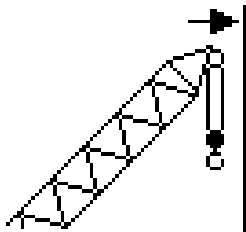

Screen now shows symbol with a black bar to the right and the set value for max. radius limit, if you have set one.

(If you did not set a maximum radius limit, there will be no right black bar and no radius value displayed).

Pushing **OK** will accept setting and quit function.

Tip Height Limitation

This function allows the operator to program an audible and visual alarm for the limitation of the tip height.

To set / delete tip height limit:

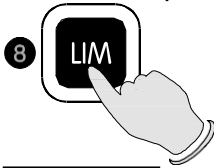

Call LIMIT Setting

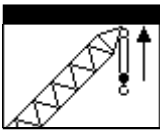

Select the corresponding symbol to select function "Tip Height Limitation".

Screen will now show:

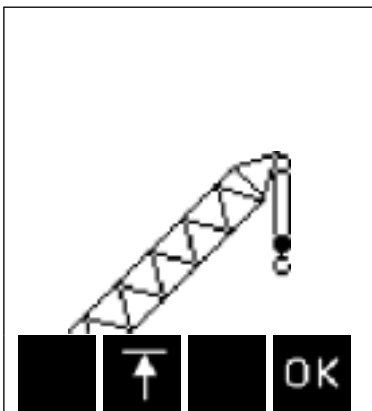

You have the choice to:

- Set a tip height limit:
- Exit the function without any changes:

If a limit has already been set, it will be shown as blacked-out area with the set value for tip height limit.

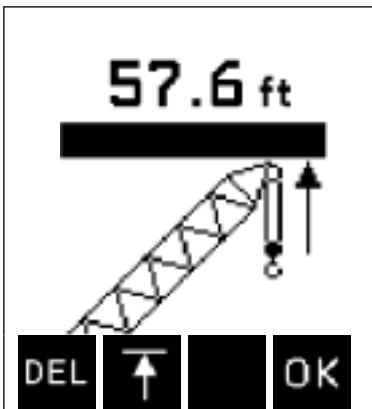

You have the choice to:

- Change the tip height limit:
- Exit the function without any changes:
- Delete the tip height limit and exit the function:

➡ To set / delete tip height limit:

Screen shows (with current tip height value): To set: _____ To delete: _____

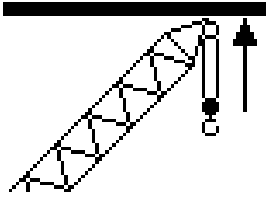

Position boom at the desired tip height value.

Push **SET** to set current tip height as tip height limit.

Push **DEL** to delete tip height limit and exit the function.

This takes you back to the previous screen, "Set / Delete Tip Height Limits":

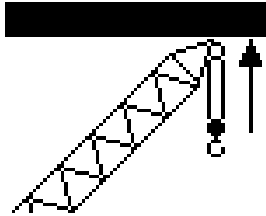

Screen now shows symbol with a black bar and the set tip height limit value, if you have set one.

(If you did not set a tip height limit, there will be no black bar and no tip height value displayed).

Pushing **OK** will accept setting and quit function.

Boom Angle Limitation

This function allows the operator to program an audible and visual alarm for the limitation of the upper and/or lower boom angle.

To set / delete boom angle limits:

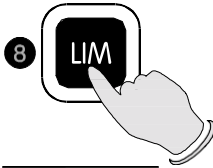

Call LIMIT Setting

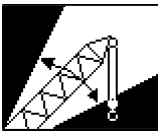

Select the corresponding symbol to call the function "Boom Angle Limitation".

Screen will now show:

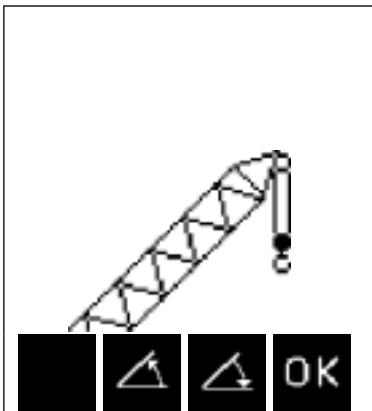

You have the choice to:

- Set a maximum (upper) boom angle limit:
- Set a minimum (lower) boom angle limit:
- Exit the function without any changes: **OK**

If a limit has already been set, it will be shown as blacked-out area with the set value(s) for radius limit:

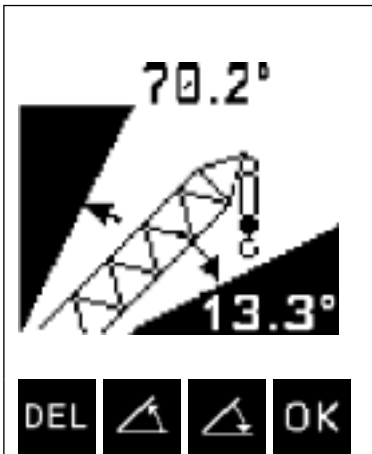

You have the choice to:

- Set a maximum (upper) boom angle limit:
- Set a minimum (lower) boom angle limit:
- Exit the function without any changes: **OK**
- Delete the angle limits and exit the function: **DEL**

➡ To set / delete maximum boom angle limit:

Screen shows (with current boom angle value):

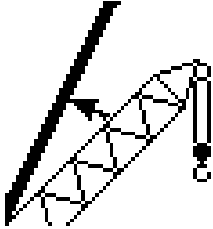

To set:

Position boom at the desired maximum boom angle.

Push **SET** to set current boom angle as maximum boom angle limit.

To delete:

Push **DEL** to delete maximum boom angle limit and exit the function.

This takes you back to the previous screen, "Set / Delete Boom Angle Limits".

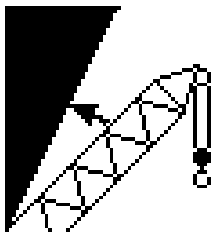

Screen now shows symbol with a black bar in the upper left corner and the set value for max. boom angle limit, if you have set one.

(If you did not set a maximum boom angle limit, there will be no upper left black bar and no boom angle value displayed).

Pushing **OK** will accept setting and quit function.

➡ To set / delete minimum (lower) boom angle limit:

Screen shows (with current boom angle value):

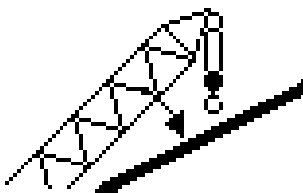

To set:

Position boom at the desired minimum boom angle.

Push **SET** to set current boom angle as minimum boom angle limit.

To delete:

Push **DEL** to delete minimum boom angle limit and exit the function.

This takes you back to the previous screen, "Set / Delete Boom Angle Limits".

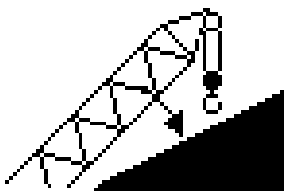

Screen now shows symbol with a black bar in the lower right corner and the set boom angle value for min. boom angle limit, if you have set one.

(If you did not set a minimum boom angle limit, there will be no lower right black bar and no boom angle value displayed).

INFO crane configuration

With the system being ready for operation, this function serves to display the system configuration
Call function

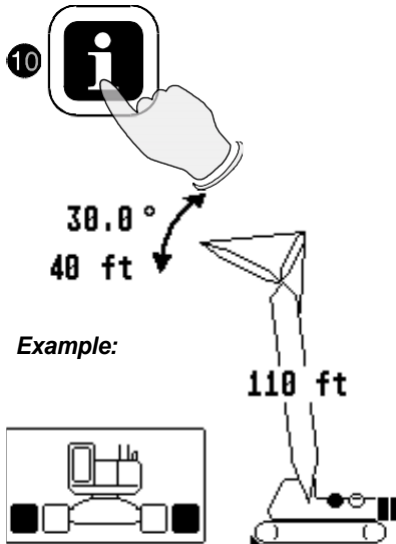

Press "INFO" button.

The display shows the crane symbol representing the selected boom configuration (here: main boom 110 ft plus jib 40 ft at a 30° offset), the adjusted configuration (marked black), i.e. counter weight selection, hoist drum selection and track position and the extended operating code.
To confirm the hoist selection, please use the function "set operating mode" (button "SELECT") ⇒ chapter 4.1, plus the function "Hoist-in-use quick selection" ⇒ chapter 4.2

End function



Press again "INFO" button.

Display Contrast Control

This function allows for the contrast adjustment of the LC display. The last adjustment is stored and will be recalled at every system start.

Contrast adjustment

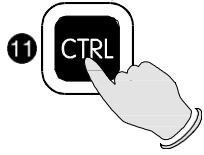

Press "CTRL".

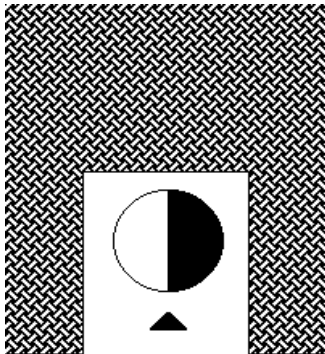

A pattern is shown which helps setting the display to the optimum contrast. Use the functional buttons to modify the contrast upon request:

- +** dar ken display
- br ighten display
- OK** conf irm setting

Press the "OK" button to store the momentarily adjusted contrast value and to quit the function.

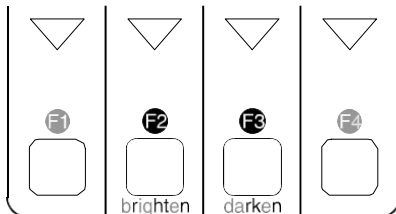

During normal LMI operation the display contrast can be adjusted too by pressing button:
 F2 (brighten display) or
 F3 (darken display).

6 PRE-OPERATION INSPECTION AND CALIBRATION VERIFICATION

Before operating the crane, the following electrical connections must be checked to ensure that the system is properly connected for the crane configuration.

If the crane works only with the boom and without boom extension or jib, check bypass plug(s) and the weight on the anti two-block switch(s) is properly installed on the hoist load line(s). With even parts of hoisting line, the weight shall be attached to the dead-end line. With odd parts of hoisting line, the weight shall be attached to the line of lowest speed.

If the crane works with boom extension or jib, the connecting cable shall be installed between the junction box on the boom extension and the boom junction box. The weight attached to the main hoist anti two-block switch shall be removed. In that case the anti two-block switch has to be locked with the red Anti Two-Block Retainer, which is fixed with a red lanyard at the anti two-block switch (described on the next pages). Then the weight shall be reattached to the boom extension anti two-block switch.

WARNING

Failure to re-position the anti two-block switch weight will prevent the over hoist system from functioning properly. No weight shall be on the main hoist anti two-block switch when the boom extension is being used.

Installation of Anti Two-Block Retainer in Locking Position Procedure (see Fig. 1 and 2):

1. Pull the cable out of the switch and bend back parallel to the boom and hold (1).
2. Slide the retainer from left side with its slot over the cable between the crimped stop and the switch (2). Push it firmly straight onto the cable guide of the Anti Two-Block switch (3).

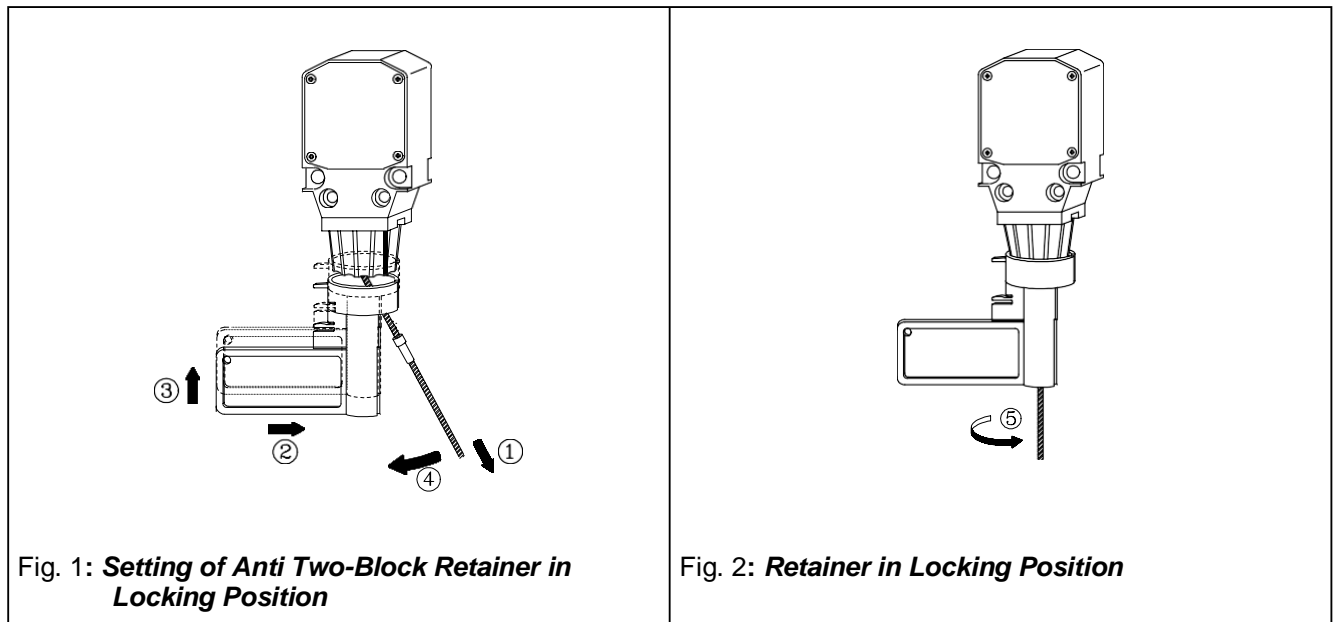

3. Straighten the cable completely into the slot and release the cable (4).

4. Turn the flag of the retainer for best visibility for the operator (5).

Removal and Storage of the Anti Two-Block Retainer Procedure (see Fig. 3 and 4):

1. Pull the cable out of the switch (1) and bend back parallel to the boom and hold (2).
2. Move the retainer down (3) and then left (4) to remove it from the Anti Two-Block switch. Release the cable.
3. For storage slide the retainer from right side (5) over the Anti Two-Block switch until the clips (A) lock into the holes (B).

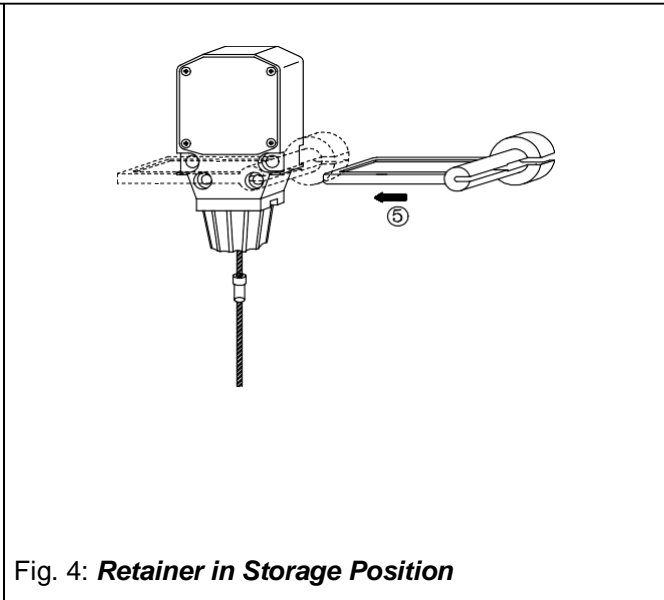
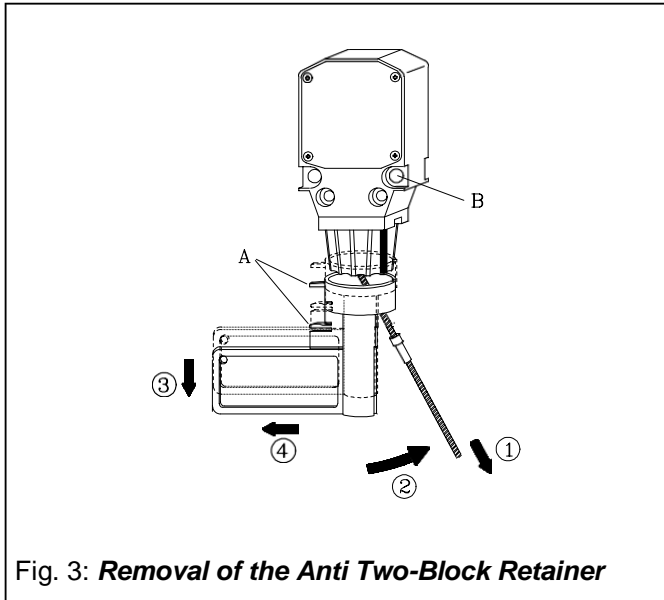

Pre-Operation Inspection and Calibration Verification

1. Check the electrical wiring connecting the various parts of the system for physical damage.
2. Check the anti two-block switches and weights for free movement.



The following tests shall be performed with care to prevent damage to the machine or injury to personnel. Proper functioning of the system requires successful completion of these tests before operating the machine.

If the operator cannot see the load-handling device approaching the boom nose, he shall have an assistant (signal person) watch the load-handling device. The operator shall be prepared to stop the machine immediately should the LMI system not function properly as indicated by lighting the red warning light (4), sounding the audible alarm (12) and locking the crane movements, hoist up, telescope out and boom down.

3. Check the anti two-block alarm light (4) and the audible alarm (12) by performing one of the following tests:
 - a. By manually lifting the weight attached to the anti two-block switches. When the weight is lifted, the audible alarm (12) should sound, the anti two-block alarm light (4) should light.
 - b. Slowly raise the main boom load-handling device to create a potential two-block condition. When the load-handling device lifts the weight, the audible alarm (12) should sound, the anti two-block alarm light (4) should light and the motion of the load-handling device should be stopped. Lower the load-handling device slightly to eliminate this condition.
 - c. Slowly lower the boom to create a potential two-block condition. When the load-handling device lifts the weight, the audible alarm (17) should sound, the anti two-block alarm light (24) should light and the boom lowering function should be stopped. Lower the load-handling device slightly to eliminate this condition.



If the light and audible alarm do not function as described and the crane movements are not stopped, the system is not working properly. The malfunction shall be corrected before operating the crane.

4. If the crane is equipped with a boom extension, repeat the test procedure for the boom extension anti two-block switch.
5. Check that the display of the main boom angle agrees with the actual boom angles.
6. Check that the display of the operating radius of the crane agrees with the actual radius.
7. Check the load display by lifting a load of known weight.

Operation

Upon correct inspection and calibration of the LMI is operational. The operator shall be thoroughly familiar with all controls of the LMI before operating the crane. The proper function of the system shall be checked by lifting a load of known weight and comparing the load to the information displayed on the LMI. Refer to Section 9. Calibration, of this manual for calibration procedures.

Rated loads include the weight of the hook block, slings, and auxiliary load handling devices. Their combined weights shall be subtracted from the listed load capacities as stated on the load capacity chart to obtain the net load to be lifted.



If any of the displayed values reflect a deviation between displayed and actual values, contact an authorized SkyAzul service representative for repair of the system.



Any structural modifications or changes to the crane shall require re-verification of the crane's LMI calibration.

7 SERVICE AND MAINTENANCE

Daily maintenance of the Load Moment Indicator consists of inspecting:

1. The electrical wiring connecting the various parts of the system.
If electrical wiring is damaged, it shall be replaced immediately.
2. If the insulation is worn on the electrical wiring or cable guides are damaged, these parts shall be replaced.
3. Check the anti two-block limit switches for freedom of movement.

Other than correcting the problems identified in the Malfunctions Table and replacing faulty mechanical parts and cables, no other repairs shall be performed by non-expert personnel.

8 TROUBLESHOOTING

General

In case of a malfunction of the system, the display (1) will indicate a code that identifies the system malfunction.

The error codes listed in the Malfunction Table will identify various faults that can occur with the LMI. Following the Malfunction Table are pages, which explain each fault and describe the action, which shall be taken to correct the fault.

Faults within the electronic microprocessor shall be repaired by factory trained service personnel. When these faults occur, the competent service organization shall be contacted.

Malfunction Table

<i>Error Code</i>	<i>Error</i>
E01	Fallen below the radius or above angle range
E02	Radius range exceeded or fallen below angle range
E03	Boom position is out of the permissible working area
E04	Operating mode not existing
E05	Prohibited length range

NOTE: If there is any Error Code displayed on the console, which is not listed in the Malfunctions Table, you shall call the Local Distributor.

Operating Errors

Malfunctions in the system, which are caused by, range exceeding or operating errors by the crane operator himself are indicated on the display together with an explanation. Error codes E01, E02, E03, E04, (E05), can normally be eliminated by the crane operator himself.

Error Code	Cause Elim	ination
E01	Fallen below the minimum radius or above the angle given in the load capacity chart due to luffing up the boom too far.	Boom down to a radius or angle given in the load capacity chart.
E02	The maximum radius or minimum angle given in the load capacity chart was exceeded due to luffing down the boom too far.	Boom up to a radius or angle given in the load capacity chart.
E03	Boom position is out of the permissible working area (over front).	Move boom back to the permissible working area. See lifting diagram in the load capacity charts.
E04	Operating mode switch in the console incorrectly set.	Correctly set operating mode switch to the code assigned to the operating mode of the crane.
	Operating mode is not permissible with the actual crane configuration, boom position or area definition.	Be sure crane is set up according to proper operating configurations.

9 Calibration

General Information

A calibration is required to define the load, radius, and boom angle for a specific crane configuration. The calibration adjusts boom weights, deflection, and offsets in main boom and extension configurations, which will be used to calculate the load moment to aid the operator in determining the crane limits for the specific operating configuration.

This calibration procedure must be completed when a new boom configuration is assembled and the new configuration has not been stored in memory. The DS350 modular system will automatically enter the calibration mode when an operating configuration has been selected that is not stored in calibration memory.

NOTE: The zero setting of the force transducer requires that the pendent be disconnected, so there are no external forces on the transducer.

What must be calibrated?

Any main boom length that will be used during crane operation, lengths must be in increments as defined by the load chart. It is best, when assembling the boom you use manufacturing guide lines, or if no guide lines exist, assemble the boom starting with the heaviest sections at the boom base and the lighter sections added at the boom tip.

NOTE: If the main boom is built with the same sections but in a different order as previously calibrated, this is a new configuration and must be calibration.

Adding an auxiliary boom extension to a calibrated main boom length does not require calibration. However, if the new main boom length requires calibration and a tip extension will be use, calibrate the main boom with the tip extension.

Any main boom length, jib length, and offsets used during crane operation (i.e. 60' main boom, 40' jib, or 30' of offset is one calibration), if either the main length, jib length, or jib offset is changed and the calibration is not stored in memory, the configuration must be calibrated. However, the main boom with the jib erected but not used can be calibrated separately from the jib.

Material required for calibration:

- Calibrated inclinometer (for setting boom angle)
- Known loads, weight is depended on configuration, loads should be within 50 to 75% of max load for the defined radius.
- Tape measure (to measure the radius of the block/ball)

Calibration memory

Calibration memory stores the last five calibrations, the sixth calibration will replace the least used or oldest calibration.

CALIBRATION CONFIGURATION SETUP

Complete the configuration setup in Chapter 4 of this manual, this operating mode must correspond with the cranes current configuration. When a mode is selected, the system scans the calibration memory for existing calibrations. If a calibration cannot be found, then the calibration procedure for the selected configuration is initiated. The operating mode / crane configuration selected will correspond to the calibration mode completed in 9.4. Calibration Mode.



The correct setting is of utmost importance for the proper functioning of the system and the crane. Therefore, only operators who are thoroughly familiar with the crane and the operation of the system should execute the setting of the system according to the operating configuration of the crane.

CALIBRATION ZERO SETTINGS

The first time the system is calibrated it will request a zero setting for the force transducer and a mechanical verification on the angle sensor. The zero setting of the sensors will effect all calibrations; therefore requires a service code to be entered. The service code is an acknowledgment from the operator that this information is the basis for all calibrations stored in memory. The service code to enter the zero setting is 67676.

After the first calibration, the zero setting can be accessed from the operating screen by pressing "INFO" (10) and then "CTRL" (11) buttons and entering the service code defined above.

Reasons to access the zero settings are:

- First calibration
- After replacing the force transducer
- After troubleshooting a load reading problem that is incorrect. Zero point adjusts is the one of the last steps in troubleshooting a load reading problem.



The correct zero setting is of utmost importance for the proper functioning of the system and the crane. Therefore, only operators who are thoroughly familiar with the crane and the operation of the system should execute the zero setting of the system according to the following information in this section.

The system will then give you the option to zero the force transducer or enter the calibration mode.

NOTE: The zero setting of the force transducer requires that the pendent be disconnected, so there are no external forces on the transducer

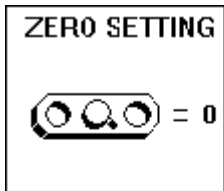

◀ 1

1 Zero Force Transducer

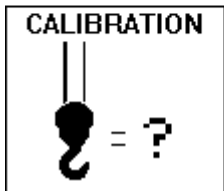

◀ 2

2 Calibration Mode

After pressing zero setting #1 the following two screens will be displayed.

The calibration option here on this screen will not be shown if there is no calibration stored in memory.

Force Sensor
Adjustment
Zero Sensors

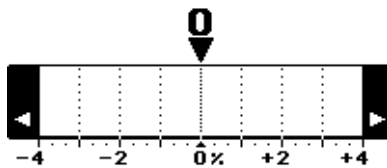
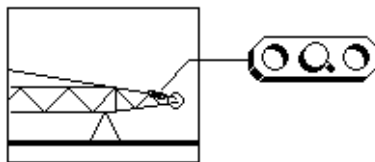

The Force transducer zero point is set in the software through the console. The zero setting of the force transducer requires that the pendent be disconnected, so there are no external forces on the transducer.

The “AUTO” buttons are to set the zero point of the force transducer. Simultaneously hold down plus and minus buttons (automatic zero) for about 3 seconds or until the line positions itself at the zero point.

⇒ confirm force setting

Angle Sensor Adjustment

The angle ϕ shown in Figure 1 needs to be within $+0$, -0.4 of the actual angle when the boom is at 70 degrees. Check boom angle at base/heel Section only. After adjustment, compare the actual boom angle using the calibrated inclinometer with the displayed angle at about 0° , 30° and 60° . To comply with the SAE J375 standards the displayed angle must be $+0.0^\circ$ to -2.0° of the actual angle.

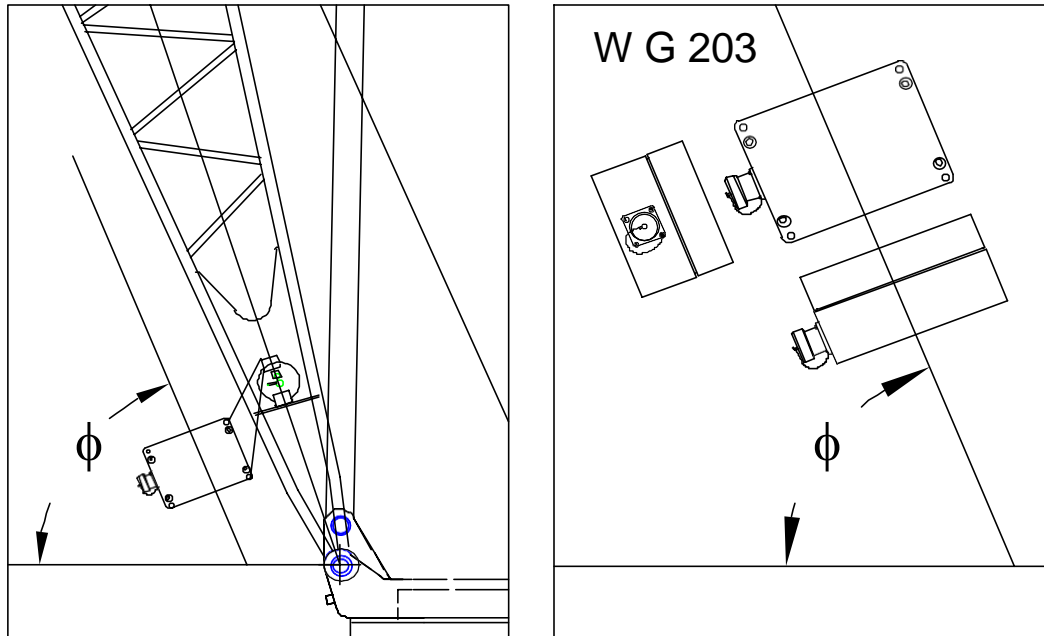
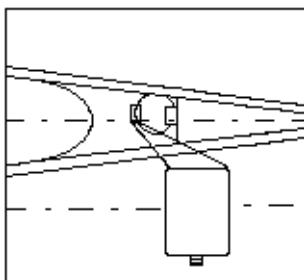
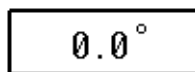

Figure. 1. Angle Sensor Adjustment.

Zero Sensors



Set mechanically



The angle must be set mechanically. The angle reading shown in this screen is the same as shown on the operating screen.

ESC confirm main boom angle using a calibrated inclinometer

CALIBRATION MODE

If the calibration is not stored in memory, the system will automatically enter calibration mode with the first screen below. To enter the calibration mode from the operating screen press “INFO” (10) and then “CTRL” (11) buttons. The system will then give you the option to zero the force transducer or enter the calibration mode. Refer to 9.3 CALIBRATION ZERO SETTINGS to zero the procedure.

NOTE: After the calibration mode has been started, to return to the operating screen or restart calibration press “SEL” button. All screens must be completed and acknowledged before the calibration will be saved to memory.

Use the appropriate section to guide you through the calibration:

- 9.4. 1. main boom calibration
- 9.4.2. jib calibration
- 9.4.3. main boom and jib calibration

The following screen is a sample of a calibration screen and description of the values shown.

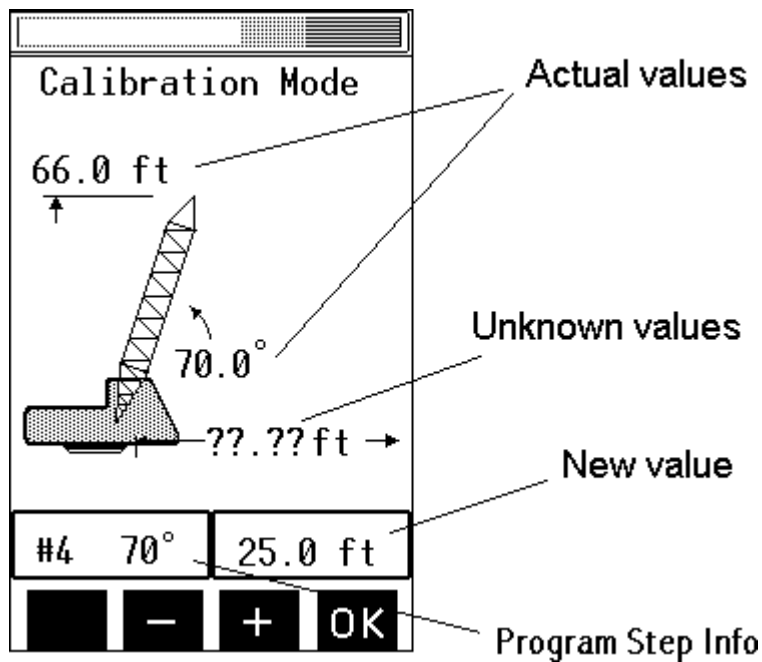

Radius: the distance from the centerline of rotation to the hook block. Remember to add the distance from the centerline of rotation to the point on the upper or lower frame from which measurements are taken.

Main Boom Calibration

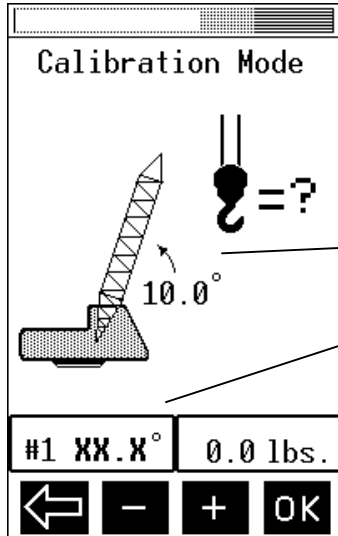

Step 1: Boom to indicated angle $\pm 0.5^\circ$. With the hook block suspended, enter the weight of the hook block. *NOTE: There is to be no load on hook at this time.* Use the + and - button to change the weight to the nearest 100 lbs. above the actual weight of the hook block or overhaul ball. Press OK when complete.

Actual angle

Indicated angle

Note: the angle will be automatically selected based on the minimum angle allowed by the selected operating mode.

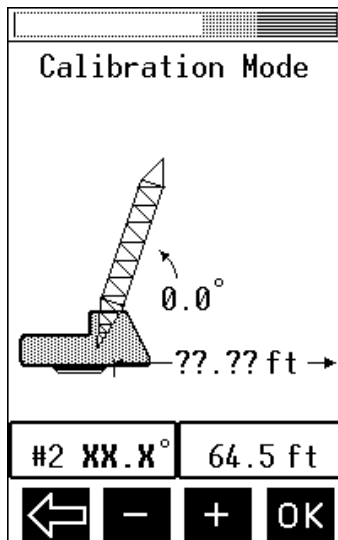

Step 2: Boom to indicated angle $\pm 0.5^\circ$. Take a radius measurement from the centerline of rotation to the block/ball. Enter the actual measured radius. Use the + and - button to change the value shown. Press OK when complete.

Note: the angle will be automatically selected based on the minimum angle allowed by the selected operating mode.

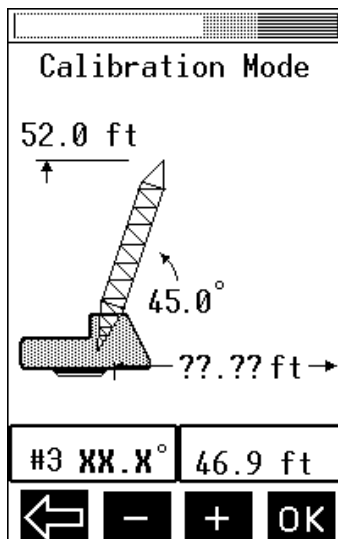

Step 3: Boom to indicated angle $\pm 0.5^\circ$. Take a radius measurement from the centerline of rotation to the block/ball. Enter the actual measured radius. *NOTE: There is to be no load on hook at this time.* Use the + and - button to change the value shown. Press OK when complete.

Note: the angle will be automatically selected based on the following formula:

$$[(\text{max angle} - \text{min angle}) \div 2] + \text{min angle}$$

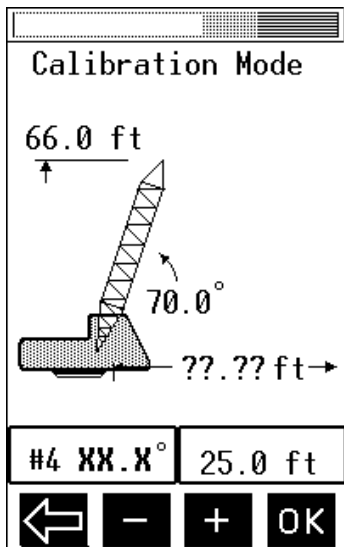

Step 4: Boom to indicated angle $\pm 0.5^\circ$. Take a radius measurement from the centerline of rotation to the block/ball. Enter the actual measured radius. *NOTE: There is to be no load on hook at this time.* Use the + and - button to change the value shown. Press OK when complete.

Note: the angle will be automatically selected based on the maximum angle allowed by the selected operating mode.

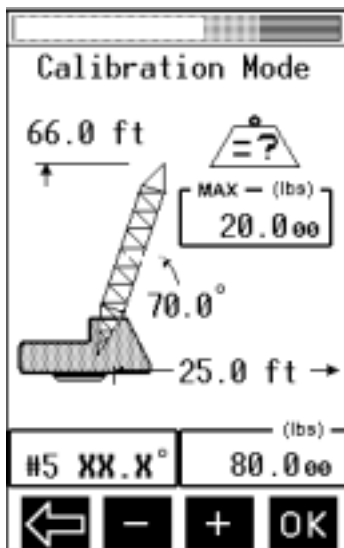

Step 5: Lift a load that is near the maximum allowable load for the indicated angle and the given configuration. Be sure to consider all required deductions.

Enter the weight of the total load to match the load on hook (including the hook block or overhaul ball, and any rigging). Adjust the weight to the nearest 100 lbs. above the actual weight Include all load handling devices. Use the + and - button to change the value shown. Press OK when complete.

NOTE: Known loads, weight is depended on configuration, loads should be within 50 to 75% of max load for the defined radius. To comply with SAE J376 standards, the test load must be to a known accuracy of $\pm 1\%$.

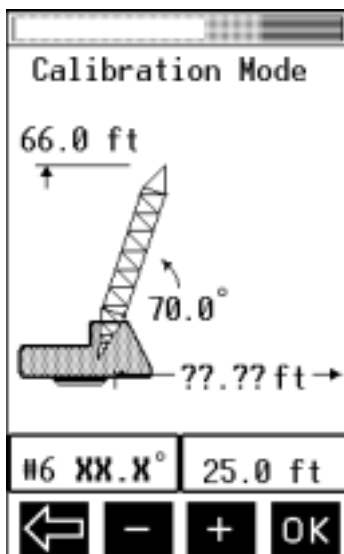

Step 6: With test load still on hook block/ball, take a radius measurement from the centerline of rotation to the block/ball. Enter the actual measured radius. Use the + and - button to change the value shown. Press OK when complete

Main boom complete .If calibrating only a main boom, calibration ends at this point and the operating screen appears.

Ji b Calibration

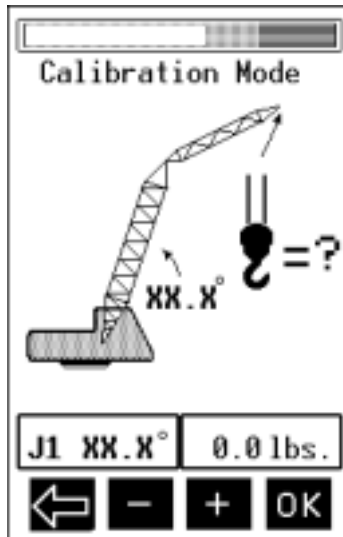

Step J1: Boom to the indicated angle $\pm 0.5^\circ$. With the block suspended, enter the weight of the hook block. *NOTE: There is to be no load on hook at this time.* Use the + and – button to change the value shown. Press OK when complete.

Note: the angle will be automatically selected based on the minimum angle allowed by the selected operating mode.

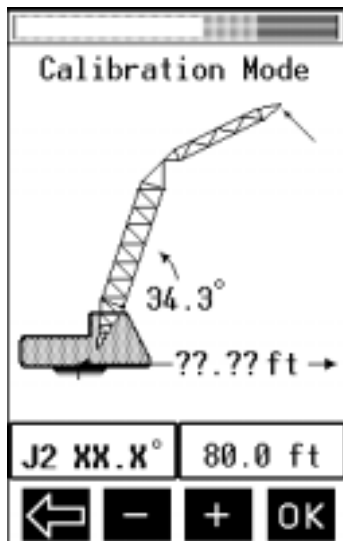

Step J2: Take a radius measurement from the centerline of rotation to the block/ball. Enter the actual measured radius. Use the + and – button to change the value shown. Press OK when complete

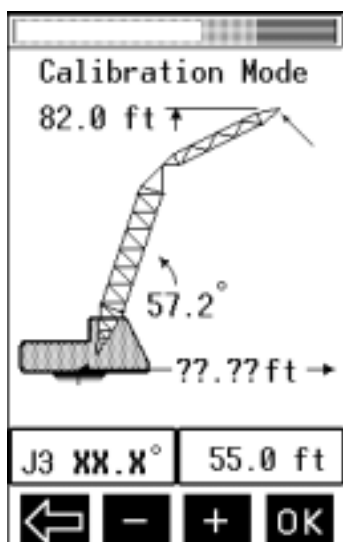

Step J3: Boom to the indicated angle $\pm 0.5^\circ$. Take a radius measurement from the centerline of rotation to the block/ball. Enter the actual measured radius. *NOTE: There is to be no load on hook at this time.* Use the + and – button to change the value shown. Press OK when complete.

Note: the angle will be automatically selected based on the following formula:

$$\left[(\text{max angle} - \text{min angle}) \div 2 \right] + \text{min angle}$$

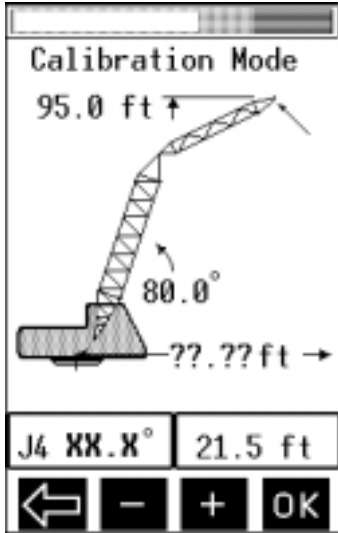

Step J4: Boom to the indicated angle $\pm 0.5^\circ$. Take a radius measurement from the centerline of rotation to the block/ball. Enter the actual measured radius. *NOTE: There is to be no load on hook at this time.* Use the + and - button to change the value shown. Press OK when complete.

Note: the angle will be automatically selected based on the maximum angle allowed by the selected operating mode.

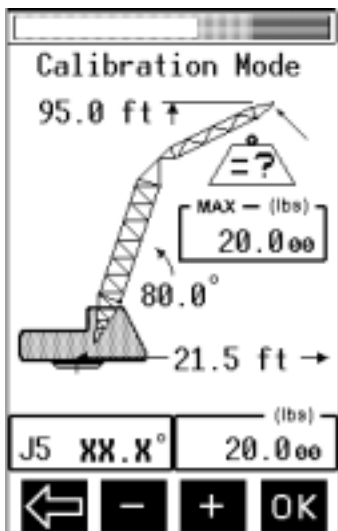

Step J5: Lift a test load that is near the maximum allowed load for the indicated angle. Be sure to consider all required deductions.

Enter the weight of the load to match the load on hook (including the hook block or overhaul ball, and any rigging). Adjust the weight to the nearest 100 lbs. above the actual weight Include all load handling devices. Use the + and - button to change the value shown. Press OK when complete.

NOTE: Known loads, weight is depended on configuration, loads should be within 50 to 75% of max load for the defined radius. To comply with SAE J376 standards, the test load must be to a known accuracy of $\pm 1\%$.

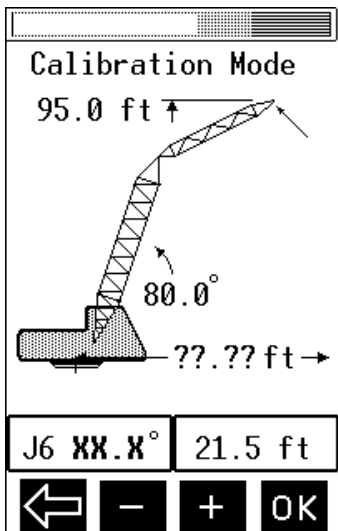

Step J6: With test load still on hook block/ball, take a radius measurement from the centerline of rotation to the block/ball. Use the + and - button to change the value shown. Press OK when complete

Jib complete .If calibrating only a jib, calibration ends at this point and the operating screen appears.

Main Boom and Jib Calibration

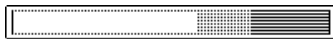

Calibration Mode

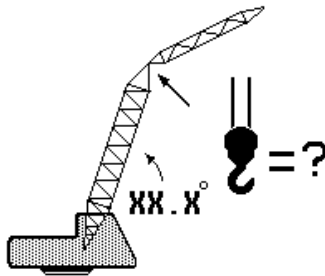

Step M1: Boom to the indicated angle $\pm 0.5^\circ$. With the block suspended, enter the weight of the hook block. *NOTE: There is to be no load on hook at this time.* Use the + and - button to change the value shown. Press OK when complete.

Note: the angle will be automatically selected based on the minimum angle allowed by the selected operating mode.

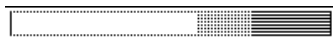
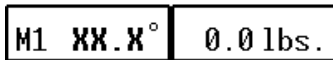

Calibration Mode

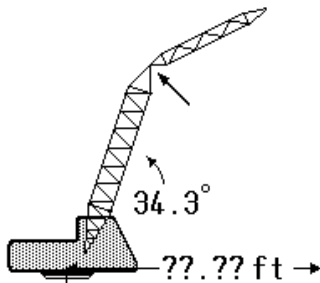

Step M2: Take a radius measurement from the centerline of rotation to the block/ball. Enter the actual measured radius. Use the + and - button to change the value shown. Press OK when complete

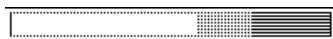
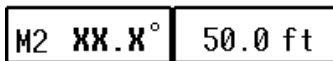

Calibration Mode

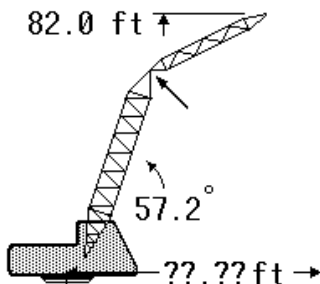

Step M3: Boom to the indicated angle $\pm 0.5^\circ$. Take a radius measurement from the centerline of rotation to the block/ball. Enter the actual measured radius. *NOTE: There is to be no load on hook at this time.* Use the + and - button to change the value shown. Press OK when complete.

Note: the angle will be automatically selected based on the following formula:

$$[(\text{max angle} - \text{min angle}) \div 2] + \text{min angle}$$

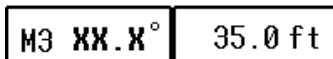

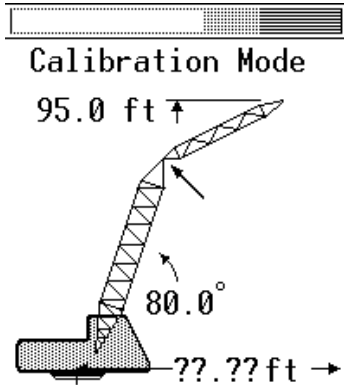

Step M4: Boom to the indicated angle. Take a radius measurement from the centerline of rotation to the block/ball. Enter the actual measured radius. *NOTE: There is to be no load on hook at this time.* Use the + and – button to change the value shown. Press OK when complete.

Note: the angle will be automatically selected based on the maximum angle allowed by the selected operating mode.

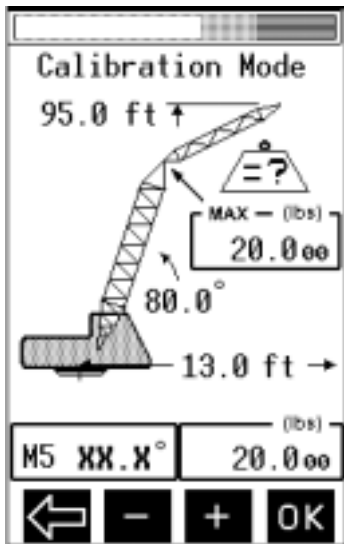
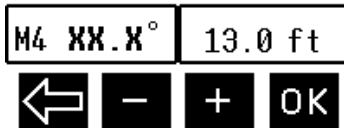

Step M5: Lift a load that is near the maximum allowed load for the indicated angle. Be sure to consider all required deductions. Enter the weight of the load to match the load on hook (including the hook block or overhaul ball, and any rigging). Adjust the weight to the nearest 100 lbs. above the actual weight Include all load handling devices. Use the + and – button to change the value shown. Press OK when complete.

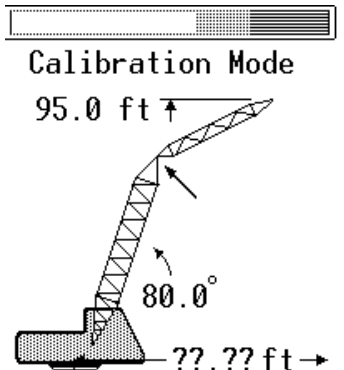

Step M6: With test load still on hook block/ball, take a radius measurement from the centerline of rotation to the block/ball. Use the + and – button to change the value shown. Press OK when complete

